

***TEXEL***

**MAGNETIC DRIVE CHEMICAL PUMPS**



**ME SERIES**  
INSTRUCTION MANUAL

**PHONE (713) 972-8666 3575 West 12th Street Houston, TX 77008 FAX (713) 972-8665**  
**[www.magnatexpumps.com](http://www.magnatexpumps.com)**

**!WARNING! - MAG DRIVE PUMP**

DO NOT WORK ON THIS PUMP IF YOU ARE WEARING A MEDICAL DEVICE (DEFIBRILLATOR, PACEMAKER, ETC.) PERSONNEL WHO EXPERIENCE INTERFERENCE WITH THEIR MEDICAL DEVICE SHOULD MOVE AWAY FROM THE PUMP AND REFRAIN FROM HANDLING MAGNETIC PUMP COMPONENTS. SEEK IMMEDIATE MEDICAL ATTENTION IF YOU HAVE EXPERIENCED INTERFERENCE WITH YOUR MEDICAL DEVICE.

The rare earth permanent magnets in this pump have been manufactured such that the magnetic field is directional toward each half of the magnetic coupling. For this reason, the magnetic field that exists outside of the assembled magnetic coupling is minimal. When the two halves are apart, the magnetic field is exposed, which is why we recommend that personnel wearing medical devices DO NOT HANDLE the magnetic coupling components. When the pump is assembled, the magnetic fields from the magnetic coupling components are not exposed and it is safe for wearers of medical devices to be in the general proximity of the assembled pump, whether the pump is in operation or not.

# 1 Preface

---

Thank you very much for purchasing our ME (MER/MEH/MEL) Series Texel Magnetic Drive Pump. This magnetic drive pump is constructed mainly of PVDF (Polyvinylidene Fluoride); in addition Ceramic and PTFE (Polytetrafluoroethylene) have been used to achieve superior corrosion resistance. Furthermore, a magnetic coupling employed in the pump eliminates leakage. Easy maintenance, a reduction in operation costs and energy saving make this pump ideally suited to today's requirements. Please read this manual carefully for proper handling and usage of the Texel Magnetic Drive Pump.

## 2 Checking Points when Unpacking on Arrival

---

- (1) Does the name-plate correspond to what you ordered?
- (2) Are all the accessories supplied?
- (3) Have any of the components been damaged in transit?
- (4) Are any of the bolts loose?
- (5) Can the motor be turned easily by hand?  
If heavy resistance is felt, or the motor does not turn at all, this means it has been damaged in shipping.

### Contents

1. Preface .....	1
2. Checking Points when Unpacking on Arrival .....	1
3. Installation and Piping .....	2
4. Precautions for Operation .....	4
5. Maintenance Check .....	5
6. Disassembly and Assembly .....	6
7. Dry-Run Protector .....	11
8. Accident and Cause .....	13

# 13 Installation and Piping

## (1) Installation

- ① Basically, the pump base should be installed on a concrete foundation. If this is not possible, install it on a steel or wooden frame. In this case, select a solid, stable frame in order to avoid vibration during operation.
- ② In the case of a concrete foundation, place metal shims at four points between the concrete surface and the lower surface of the bracket to level the pump. Then fill the gaps with fine mortar. (Fig. 1)
- ③ Place a level on the upper surface of the discharge flange of the pump, and check pump alignment at right angles to the pump shaft.
- ④ There are no special restrictions on where the pump can be installed, but a place where inspection can be readily performed should be selected.
- ⑤ Install the pump where the height of the suction head of the pump will not be more than 6 m (20 ft) above the pumping source. The suction pipe should be as short as possible.

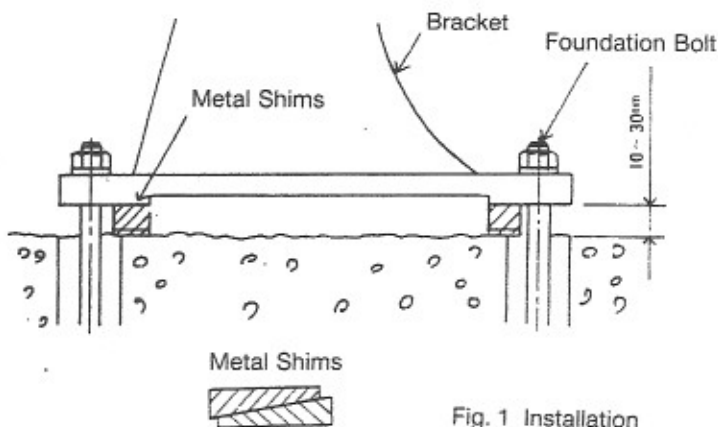

## (2) Piping

### ① Suction Pipe (Fig. 2)

- (i) Provide flange coupling joints to prevent air leaks. Special care must be taken to detect air leakage from the fittings as such leakages are not easily noticeable.
- (ii) To avoid cavitation, incline the piping upward from the suction side toward the pump. However, when using pressurized piping, incline the piping downward toward the pump.
- (iii) Provide a dust-proof screen for the suction tank. Clean out the tank before filling it with the liquid.
- (iv) Position the end of the suction pipe deep enough to be immersed even when the liquid level is low.

- (v) To prevent cavitation, the gate valve installed on the suction side should be positioned horizontally or facing downward. Be sure to keep the valve fully open except during inspection or switching.
- (vi) Make the bends as gentle as possible and keep the number to a minimum. Make sure that there are no bends near the pump suction port.
- (vii) An eccentric valve is recommended to prevent cavitation when different sized pipes are used.
- (viii) The suction piping of parallelly operated pumps may cause surging when connected to the common main piping. Separate piping is recommended in this case.

### ② Discharge Pipe

- (i) The flow velocity of the discharge opening relates to the total pump head; use specials to select the size of the discharge piping so as to make the flow velocity inside the pipe less than 3 m/sec (10 ft/sec).
- (ii) Since cavitation has adverse effects on the discharge side, install air vent valves where necessary.
- (iii) When the discharge piping forms a siphon, its highest part must be below the shut-off head of the pump.
- (iv) Install a check valve to prevent back flow during suspension of operation, or water hammer when the actual pump head is in a high position. Provide an air vent below the check valve to prevent gas/air leakage during operation. (See the Figure shown below.)

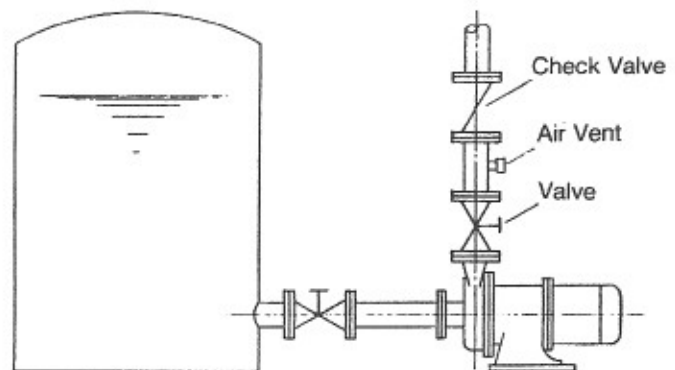
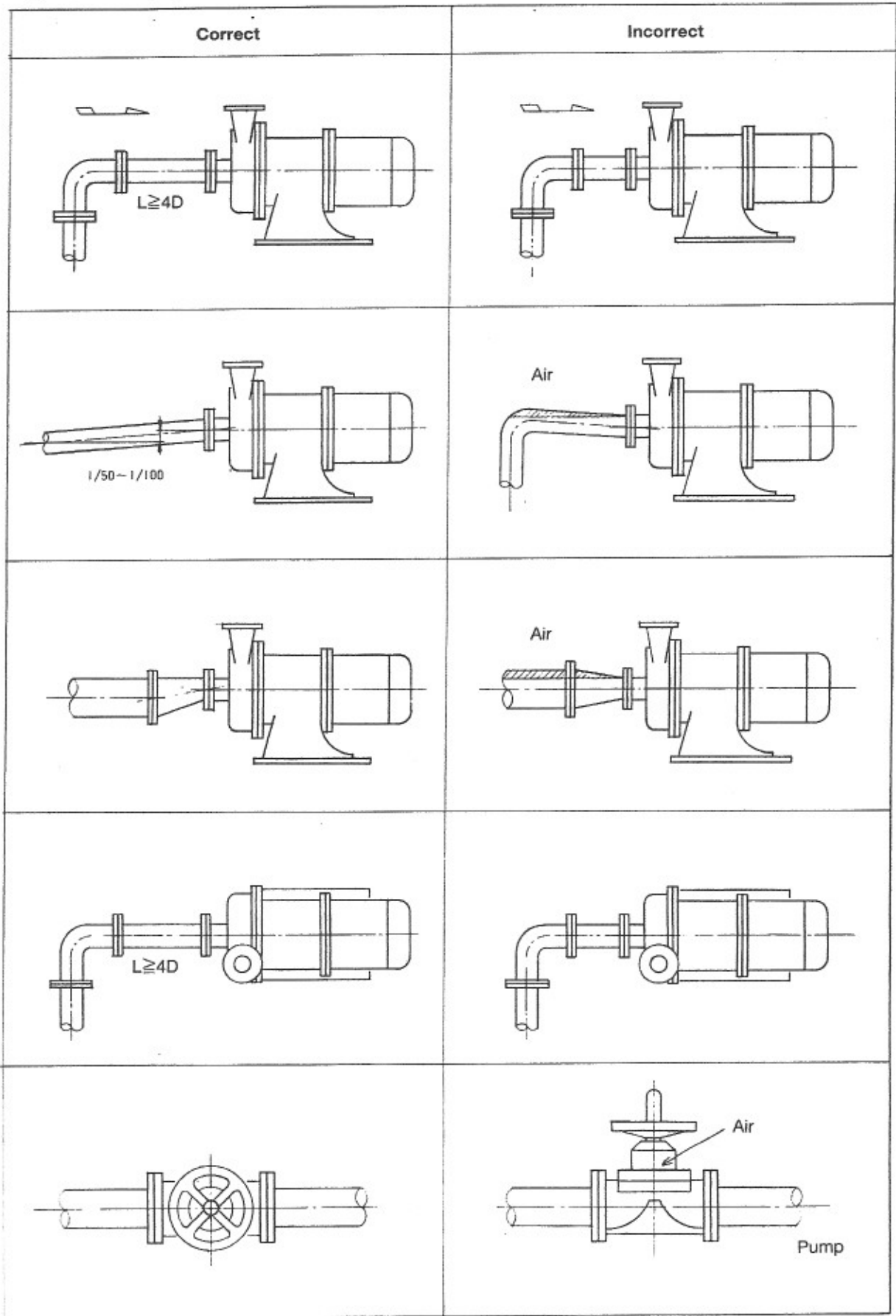

Fig. 2 Suction Piping



# 4 Precautions for Operation

## (1) Starting-Up

- ① Turn the motor manually to confirm that it rotates smoothly.
- ② Clean the inside of the suction piping. If dirt and scales, which entered the suction piping during installation, are not cleaned away, they may flow into the pump, causing critical malfunction.
- ③ Confirm the rotational direction of the motor. (Direction indicated by arrow on the casing cover)
- ④ Open the valve on the suction side pipe line completely.
- ⑤ Start operation with the discharge valve fully closed.
- ⑥ After confirming the rated speed and pressure and that the pressure has risen, gradually open the discharge valve to gain the specified discharge pressure.
- ⑦ In order to fill the pump completely, priming is required. To prime the pump, use the discharge side piping to discharge air. If difficulty is experienced in discharging air, rotate the motor fan in the reverse direction by hand three or four times and utilize the reaction.

## (2) During Operation

- ① Noise Check  
Sucking of air or solids from the suction pipe line often causes abnormal noise and vibrations.
- ② Vibration Check  
Take special care to avoid vibrations caused by cavitation.
- ③ Regulation of the discharge volume must be carried out using the valve on the discharge side. Do not close the valve on the suction side.
- ④ Special care should be taken to observe the discharge and suction pressure, discharge quantity and electric current. When the discharge pressure fluctuates or falls abnormally, the cause can often be found in clogging of solids on the suction side or in suction of air.

## (3) Suspension of Operation

- ① Normally, operation of the pump should be stopped only after fully closing the discharge valve. If the suction valve is closed first, cavitation and seizure may occur.
- ② In the case of flooded suction, close the suction valve after stopping operation.
- ③ If operation closes down due to power failure, turn off the power switch and close the discharge valve manually.

## (4) Shut-Down Operation

In the case of a long term shut-down, remove the liquids from the pump. If liquid is left inside the pump during the winter season, expansion of the liquid due to freezing may cause cracks and other damage.

## (5) Others

- ① Do not leave a reserve pump unused for a long time. Operate it occasionally to confirm that it can be employed when necessary.
- ② Avoid dry operation of the pump even for a short time. Dry operation will cause the sliding parts immersed in liquid to seize.
- ③ Use the pump observing the specified flow rate and head. Do not use with an excessive flow.

# 15 Maintenance Check

## (1) Daily Check

- ① Check that the pump is operating without producing any abnormal noise or vibrations.
- ② Check the suction and discharge pressure as well as the liquid level of the suction tank.
- ③ Check that the electric current value of the motor does not exceed the rated current value and also check the bearing temperature.

## (2) Periodical Check

For smooth and safe operation of the pump, check each item of the pump periodically in accordance with the instructions given below. Special care should be taken in the case of the metal parts, since the outer and inner magnets feature strong magnetism. Also, special care should be taken in handling the sliding areas of the shaft, all thrust rings and bearings.

## (3) Boundary of Bearing Wear

(MER)	mm		
	A	$\phi B$	C
At Time of Shipment	6	20.5	5
At Time of Replacement	4	21.5	4

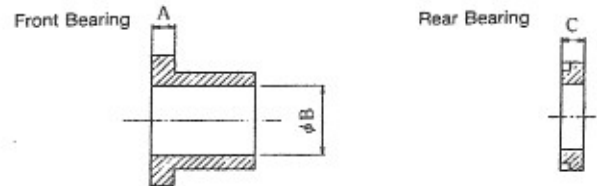

(MEH-MEL)	mm		
	A	$\phi B$	C
At Time of Shipment	5	20.5	7
At Time of Replacement	3	21.5	6

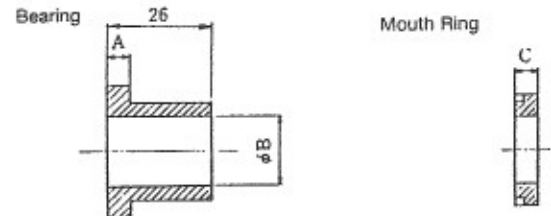

Part Name	Check Points	Measures
Casing	<ul style="list-style-type: none"> <li>● Accumulation of dirt in the liquid contact parts</li> <li>● Corrosion or swelling of O-ring</li> <li>● Presence of cracks</li> <li>● Wearing condition of Front Thrust (ring)</li> <li>● Presence of sliding flaws or cracks</li> </ul>	<ul style="list-style-type: none"> <li>● Cleaning</li> <li>● Replace if defective</li> <li>● Confirm cause</li> <li>● Confirm cause</li> <li>● Confirm cause</li> </ul>
Impeller	<ul style="list-style-type: none"> <li>● Dirt between Impeller blades or infiltration of foreign matter</li> <li>● Contact with inlet parts</li> <li>● Wearing condition of mouth ring (MEH/MEL)</li> </ul>	<ul style="list-style-type: none"> <li>● Cleaning</li> <li>● Confirm cause</li> <li>● Confirm cause</li> </ul>
Inner Magnet	<ul style="list-style-type: none"> <li>● Sliding of the outer surface and Rear Casing</li> <li>● Presence of cracks on the end face</li> <li>● Accumulation of dirt in the liquid contact parts</li> <li>● Wearing condition of Front Bearing (MEH/MEL: Bearing)</li> <li>● Clogging in the cooling passage of Front Bearing (MEH/MEL: Bearing)</li> <li>● Wearing condition of Rear Bearing</li> </ul>	<ul style="list-style-type: none"> <li>● Confirm cause</li> <li>● Confirm cause</li> <li>● Cleaning</li> <li>● Confirm cause</li> <li>● Cleaning</li> <li>● Confirm cause</li> </ul>
Rear Casing	<ul style="list-style-type: none"> <li>● Sliding of Rear Casing and Inner Magnet</li> <li>● Accumulation of dirt in the liquid contact parts</li> <li>● Wearing condition of Rear Thrust (ring)</li> <li>● Presence of sliding flaws or cracks</li> </ul>	<ul style="list-style-type: none"> <li>● Confirm cause</li> <li>● Cleaning</li> <li>● Confirm cause</li> <li>● Confirm cause</li> </ul>
Shaft	<ul style="list-style-type: none"> <li>● Presence of cracks</li> <li>● Wearing condition of Front Bearing and Rear Bearing</li> </ul>	<ul style="list-style-type: none"> <li>● Confirm cause</li> <li>● Confirm cause</li> </ul>
Outer Magnet	<ul style="list-style-type: none"> <li>● Sliding of the inner surface and Rear Casing</li> <li>● Setting position of Motor Shaft</li> <li>● Loosening of Set Screws</li> </ul>	<ul style="list-style-type: none"> <li>● Confirm cause</li> <li>● Confirm cause</li> <li>● Retighten</li> </ul>



# 6 Disassembly and Assembly

When assembling or disassembling the ME Series Pump, be careful not to damage the sliding surface of the shaft and bearings. Special care should be taken with the metal parts since the outer and inner magnets feature strong magnetism.

## (1) Disassembly

- ① Remove the drain plug and drain the liquid from the casing.
- ② Detach the casing bolts (bolt with hexagonal hole), pull out the casing cover and remove it from the bracket. At this point, the rear casing will also come out. (If the rear casing can not be pulled out due to corrosion of the bracket, detach the rear casing bolts and remove the casing cover only.) (Photos 1 & 2)

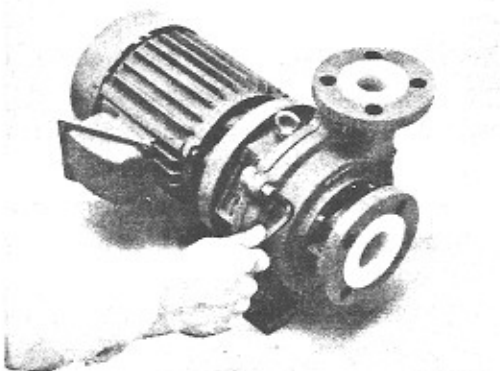

Photo 1

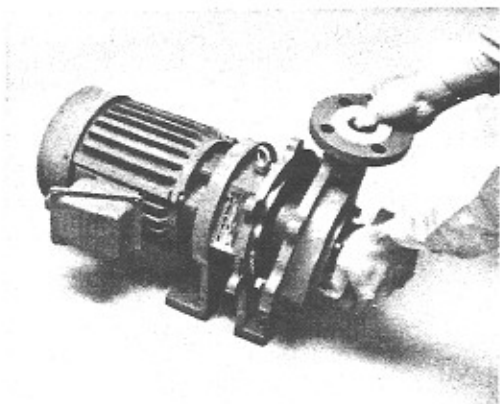

Photo 2

- ③ Place with the surface of the flange facing downward. (Photo 3)

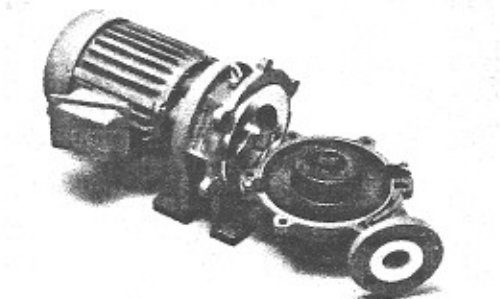

Photo 3

- ④ Detach the rear casing bolts and remove the rear casing. (Photo 4)



Photo 4

- ⑤ Pull out the inner magnet and impeller. Special care should be taken with the metal parts to prevent them being attracted by the inner magnet. (Photos 5, 6 & 7)

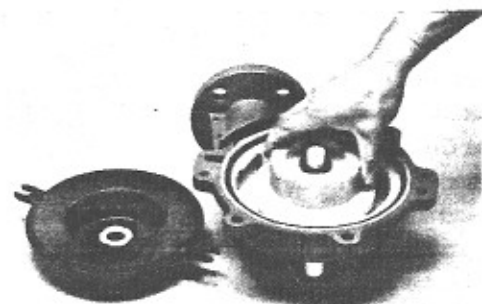

Photo 5

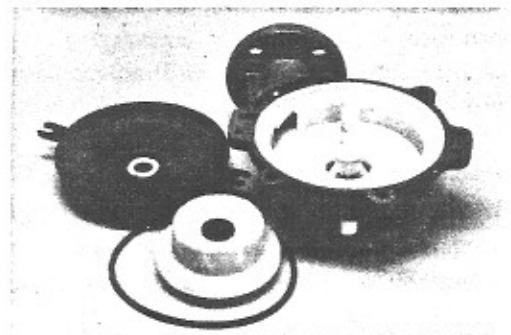

Photo 6

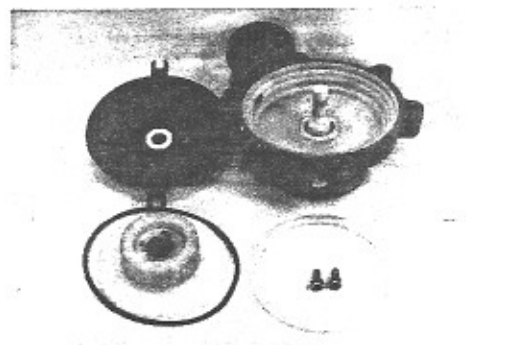

Photo 7 (MEH/MEL)



- ⑥ To separate the motor and outer magnet, remove the bracket and the motor and loosen the two set screws. Then remove the outer magnet from the motor shaft. (Photo 8)



Photo 8

**(2) Assembly**

- ① Set the suction flange with its surface downward and put the O-ring into the casing.
- ② Insert the inner magnet and impeller from the upper side.
- ③ Insert the rear casing from the upper side. Set the rear casing bolts and tighten them. (Do not fix them too tightly.)
- ④ Take the casing cover and set it on the bracket. Then tighten the casing bolts. Tighten the bolts diagonally to ensure even tightness. Take care not to injure your fingers when setting the casing cover on the bracket.
- ⑤ When assembly is completed, confirm that the motor rotates smoothly by rotating the motor fan using a screw driver or a similar tool.

**(3) Detachment/Attachment of Shaft and Front Thrust (ring)**

When detaching the shaft and front thrust ring from the casing, insert a plus driver through the hole of the casing nut (shaft support), and hammer the driver head gently with the plastic mallet; then detach. When attaching, align the notches on the shaft, front thrust ring and nut. Then hammer the rear part of the shaft using the mallet. (This does not apply to the front thrust in the case of MEH and MEL.)

(Photos 9 & 10)

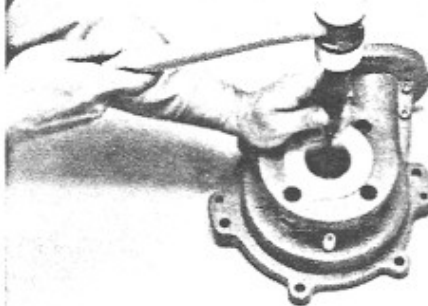

Photo 9

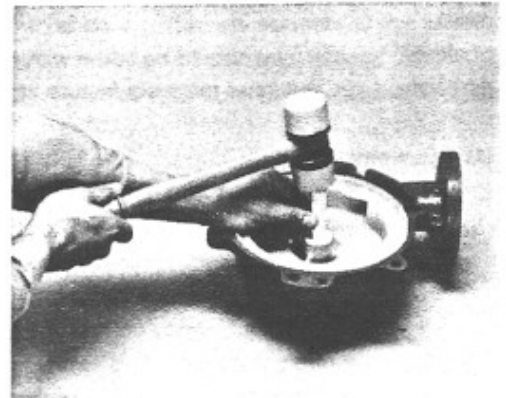

Photo 10

**(4) Replacement of MER Front Bearing/MEH, MEL Bearing**

When removing the front bearing, (or bearing in case of MEH/MEL), from the inner magnet, place a round bar (approx.  $\phi 24\text{mm}$ ) behind the front bearing, (in front of the bearing in case of MEH/MEL), and hammer it using the resin mallet. When setting the front bearing, align the notches from the impeller side, place a piece of cloth on the pad to protect from damage, and press fit by hammering lightly with the resin mallet.

(Photos 11 & 12)

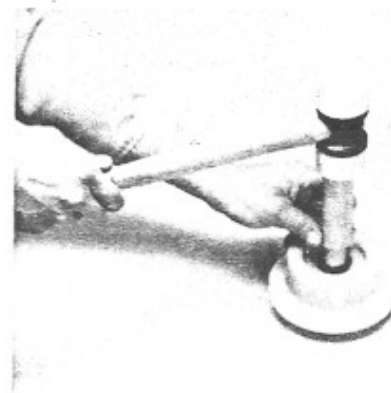

Photo 11

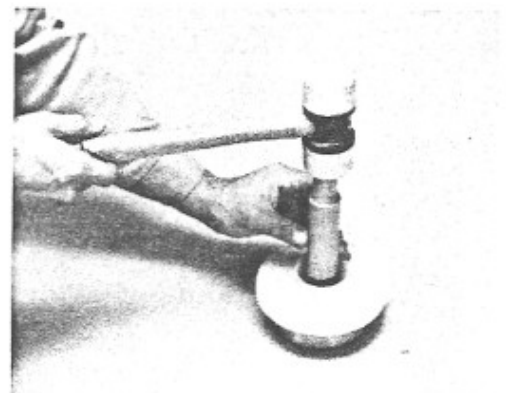

Photo 12

**(5) Replacement of MER Rear Bearing and Rear Thrust (ring)/MEH, MEL Front Thrust (ring), Mouth Ring, Rear Thrust (ring)**

The rear bearing and rear thrust ring are set with soldered claws at two places, (front thrust ring, mouth ring, and rear thrust ring in case of MEH/MEL). When replacing the rear bearing and rear thrust ring, melt and detach these claws using a hot gas welder. When installing the rear bearing and the rear thrust ring, align the notches, solder the claws with the welder and then flatten them using a round bar (approx.  $\phi 4\text{mm}$ ).

(Photos 13 & 14)

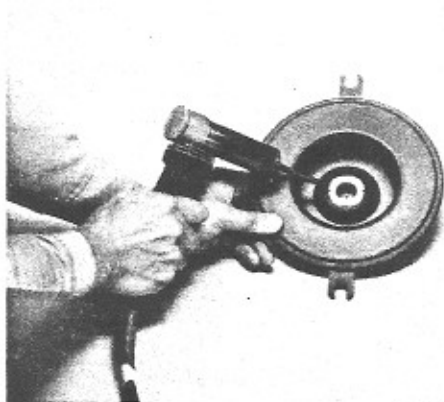

Photo 13

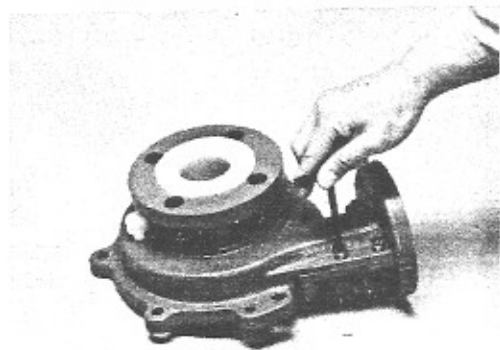

Photo 14

**(6) Replacement of Casing (Photo 15 & 16)**

- ① Detach the discharge cover bolts (three) and remove the discharge cover.
- ② Detach the suction cover bolts (six) and remove the suction cover. The upper cover can be removed easily; however, when detaching the lower cover, rotate it so that it does not make contact with the drain. When rust causes difficulty in removing the covers, use the resin mallet to hammer them lightly while detaching.  
(In the case of MEH/MEL, pull out from both sides.)
- ③ Press the surface of the suction flange by hand or hammer lightly with the resin mallet to remove the casing from the casing cover.
- ④ When attaching, set the casing on the cover and hammer gently into place with the resin mallet.
- ⑤ Next, install the lower side of the suction cover. At this point, when insertion from the side to avoid contact with the drain does not go smoothly, hammer it gently with the resin mallet.
- ⑥ Set the suction cover bolts (six) and tighten them.
- ⑦ Set the discharge cover and tighten the discharge cover bolts. (three).

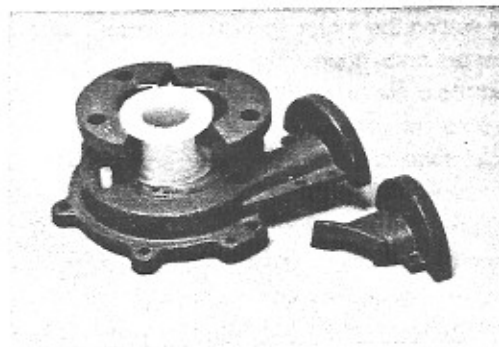

Photo 15

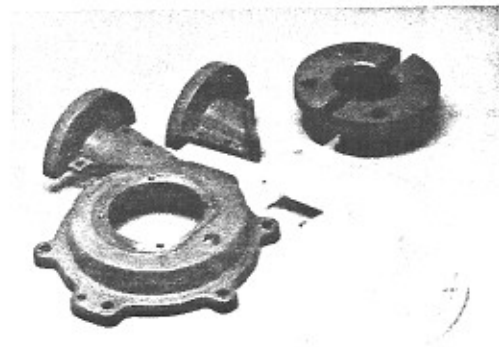
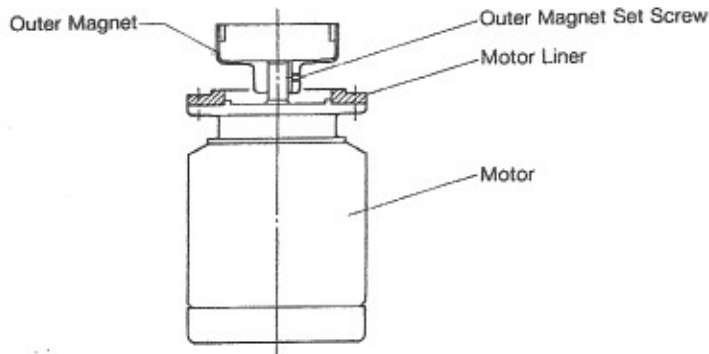

Photo 16

### (7) Installation of the IEC Motor

- ① Set the motor liner on the motor.
- ② Insert the outer magnet into the motor shaft and tighten the two outer magnet set screws.  
At this stage, take special care in setting the outer magnet and motor shaft end.
- ③ When setting of the outer magnet has been completed, insert the outer magnet in the bracket and tighten the motor set bolts (four).



### (8) Installation of the NEMA Motor

- ① Detach the motor liner which has been fixed temporarily to the bracket.
- ② After setting the motor liner on the motor, tighten with the motor set bolts (four).
- ③ Insert the outer magnet into the motor shaft and tighten the two outer magnet set screws.  
At this stage, take special care in setting the outer magnet and motor shaft end.  
The space between the outer magnet and motor shaft end should be between 0~1mm (0~0.39 inch).
- ④ When setting of the outer magnet has been completed, insert the outer magnet in the bracket and tighten the motor set bolts (four).

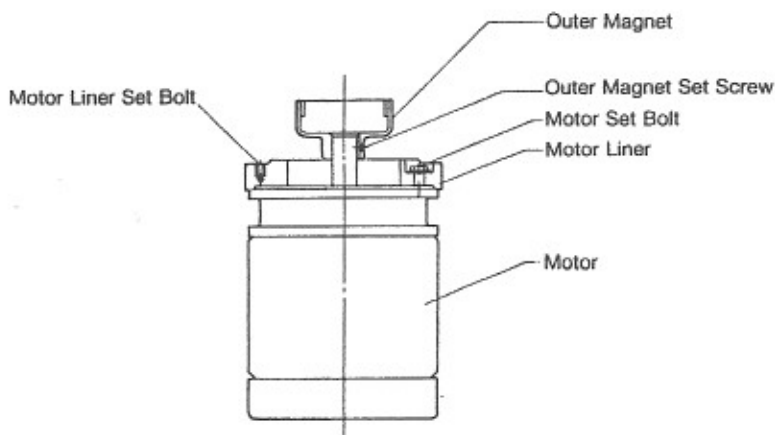

### MER Part List

Part No.	Qty.	Part Name	Material
001	1	Casing	PVDF
002	1	Casing Cover	CAST IRON
013	1	Impeller	PVDF
018	1	Shaft	CERAMIC/SiC
028	1	Bracket	CAST IRON
038	1	Drain Plug	PVDF
051*	1	* Front Bearing	TEFLON/SiC
052*	1	* Rear Bearing	TEFLON/SiC
053	1	Suction Cover	CAST IRON
054*	1	* Front Thrust	CERAMIC/SiC
055	1	Discharge Cover	CAST IRON
056*	1	* Rear Thrust	CERAMIC/SiC
057	1	Outer Magnet	RARE EARTH
058	1	Inner Magnet	PVDF + RARE EARTH
060	1	Rear Casing	CARBON-PVDF/ CARBON-PVDF + FRP
096	1	Bracket Ring	SS41
102-01*	1	* Casing Gasket	VITON/EPDM
102-12*	1	* Drain Plug Gasket	VITON/EPDM
104-03	6	Casing Cover Set Bolt	SUS304
104-24	1	Eye Bolt	SS41
104-31	6	Suction Cover Set Bolt	SUS304
104-42	3	Discharge Cover Set Bolt	SUS304
104-46	2	Outer Magnet Set Screw	S45C
104-54	2	Rear Casing Set Bolt	SUS304
901	1	Motor	—

\* Recommended spare parts for one year

### MEH/MEL Part List

Part No.	Qty.	Part Name	Material
001	1	Casing	PVDF
002	1	Casing Cover	CAST IRON
013	1	Impeller	PVDF
018	1	Shaft	CERAMIC/SiC
028	1	Bracket	CAST IRON
038	1	Drain Plug	PVDF
051*	1	* Bearing	TEFLON/SiC
053	1	Suction Cover	CAST IRON
054*	1	* Front Thrust	CERAMIC/SiC
055	1	Discharge Cover	CAST IRON
056*	1	* Rear Thrust	CERAMIC/SiC
057	1	Outer Magnet	RARE EARTH
058	1	Inner Magnet	RARE EARTH
059	1	Magnet Lining	PVDF
060	1	Rear Casing	CARBON-PVDF/ CARBON-PVDF + FRP
096	1	Bracket Ring	SS41
102-01*	1	* Casing Gasket	VITON/EPDM
102-12*	1	* Drain Plug Gasket	VITON/EPDM
104-03	6	Casing Cover Set Bolt	SUS304
104-23	4	Motor Set Bolt	SUS304
104-31	6	Suction Cover Set Bolt	SUS304
104-42	3	Discharge Cover Set Bolt	SUS304
104-46	2	Outer Magnet Set Screw	S45C
104-54	2	Rear Casing Set Bolt	SUS304
105*	1	* Mouth Ring	TEFLON/SiC
106	1	Casing Ring	PVDF
901	1	Motor	—

\* Recommended spare parts for one year

MER

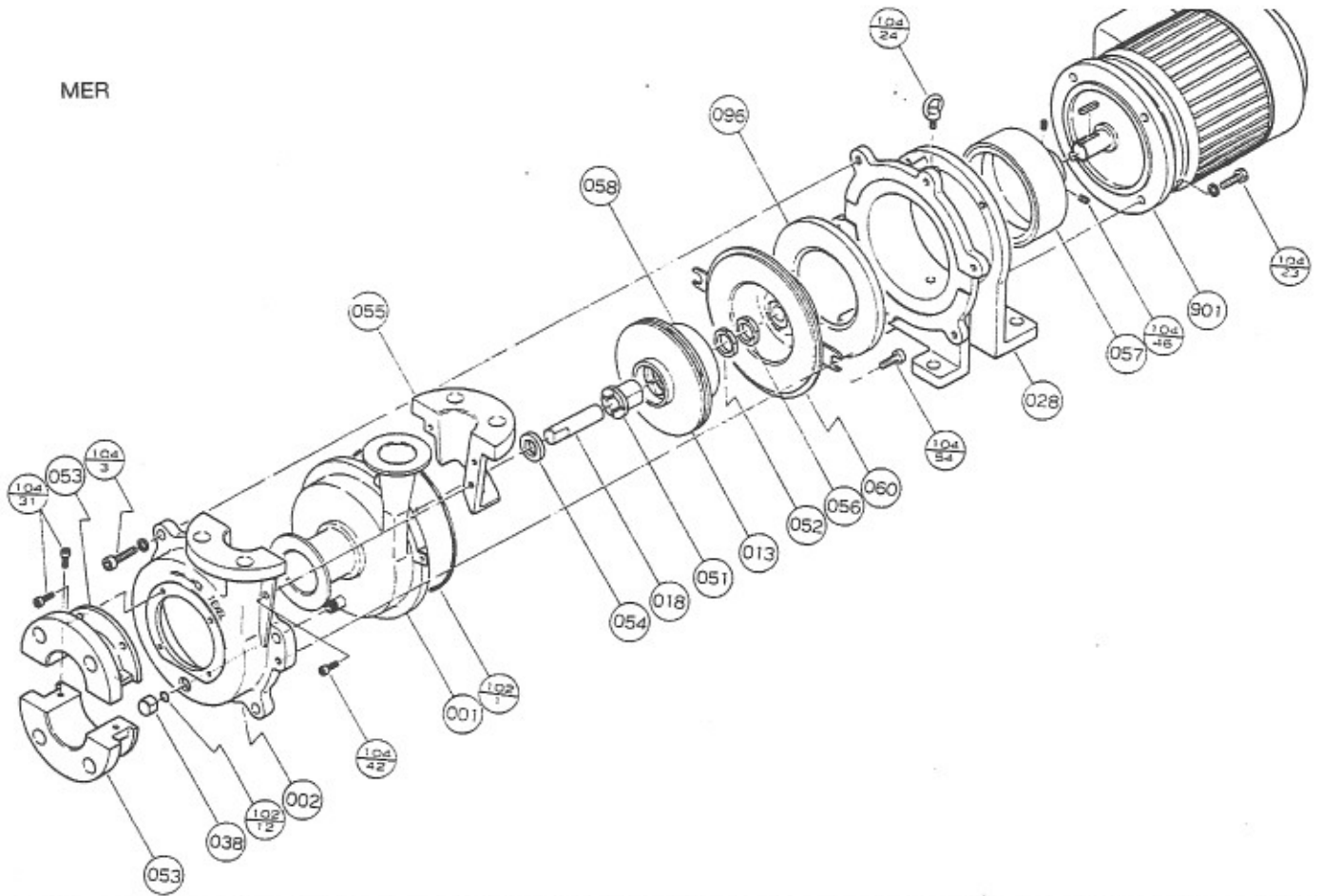

MEH/MEL

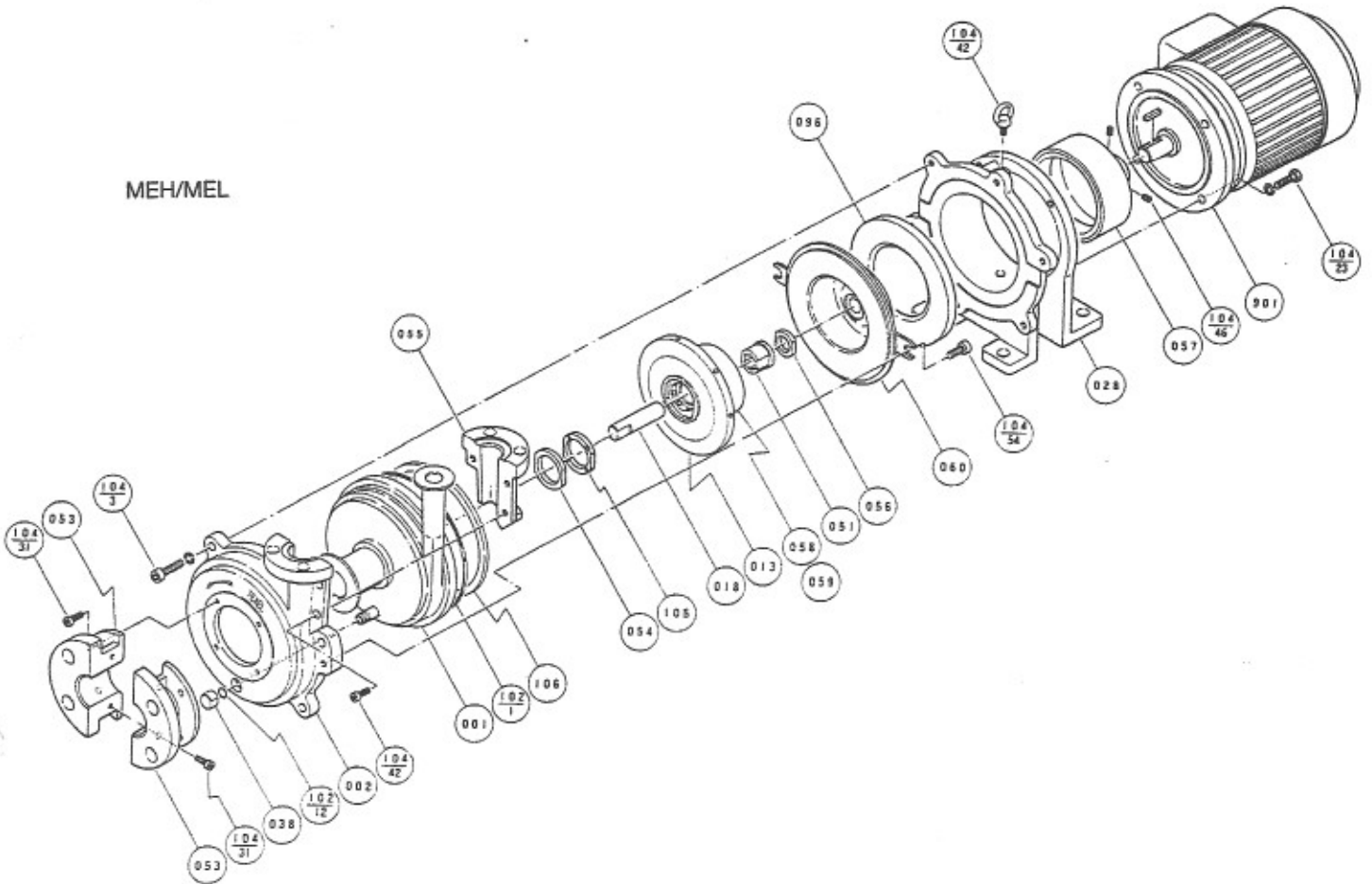

# 18 Accident and Cause

