

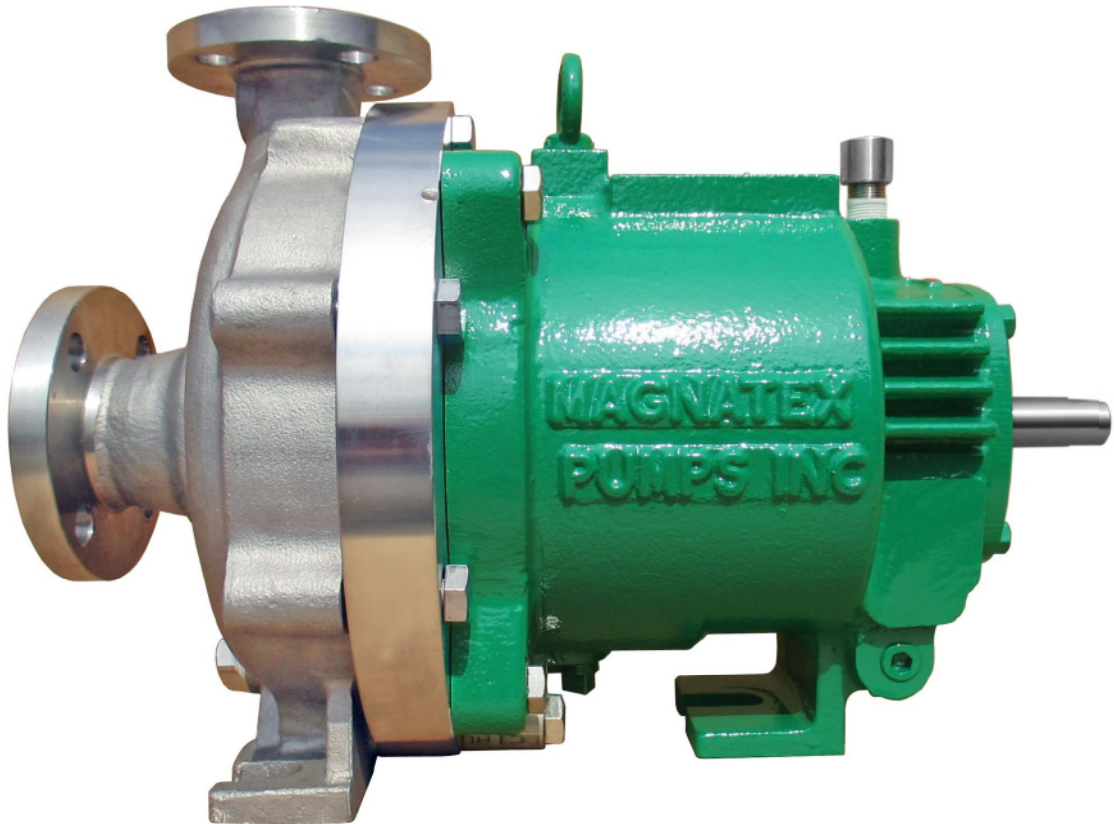

# Operation and Maintenance Manual

## Magnetic Drive Sealless Pumps

### MAXP SERIES



Magnatex Pumps, Inc.  
3575 West 12th Street  
Houston, TX 77008  
Toll Free: 866.MAG.PUMP  
Phone:713.972.8666 Fax:713.972.8665  
[www.magnatexpumps.com](http://www.magnatexpumps.com)

**!WARNING! MAG-DRIVE PUMP**

DO NOT WORK ON THIS PUMP IF YOU ARE WEARING A MEDICAL DEVICE (DEFIBRILLATOR, PACEMAKER, ETC.) PERSONNEL WHO EXPERIENCE INTERFERENCE WITH THEIR MEDICAL DEVICE SHOULD MOVE AWAY FROM THE PUMP AND REFRAIN FROM HANDLING MAGNETIC PUMP COMPONENTS. SEEK IMMEDIATE MEDICAL ATTENTION IF YOU HAVE EXPERIENCED INTERFERENCE WITH YOUR MEDICAL DEVICE.

The rare earth permanent magnets in this pump have been manufactured such that the magnetic field is directional toward each half of the magnetic coupling. For this reason, the magnetic field that exists outside of the assembled magnetic coupling is minimal. When the two halves are apart, the magnetic field is exposed, which is why we recommend that personnel wearing medical devices DO NOT HANDLE the magnetic coupling components. When the pump is assembled, the magnetic fields from the magnetic coupling components are not exposed and it is safe for wearers of medical devices to be in the general proximity of the assembled pump, whether the pump is in operation or not.

## TABLE OF CONTENTS

<b><u>SECTION HEADING</u></b>	<b><u>PAGE</u></b>
Warnings .....	2
Operating Instructions .....	4
Receipt of Equipment .....	4
Storage Procedures .....	5
Foundation .....	5
Location and Piping .....	5
Recommended A/F Bearing Lubricant .....	6
Rotation Check and Start-Up .....	6
Priming .....	7
Lubrication of Pump Process Side Bearings .....	8
Separate Flush to the Rear Casing .....	8
Operations and Maintenance .....	9
Maintenance Schedule .....	10
Torque Check .....	10
Recommended Fastener Torque Values .....	11
 <b><u>F Size MAXP Series (Pages 12-18)</u></b>	
Section Drawing .....	12
Parts List .....	13
Disassembly of Wetted End.....	14
Disassembly of Dry End .....	15
Assembly of Dry End .....	16
Assembly of Wetted End .....	17
 <b><u>M &amp; S Size MAXP Series (Pages 19-25)</u></b>	
Section Drawing .....	19
Parts List .....	20
Disassembly of Wetted End .....	21
Disassembly of Dry End .....	22
Assembly of Dry End .....	23
Assembly of Wetted End .....	24
 <b><u>L Size MAXP Series (Pages 26-33)</u></b>	
Section Drawing .....	26
Parts List .....	27
Disassembly of Wetted End .....	28
Disassembly of Dry End .....	29
Assembly of Dry End .....	31
Assembly of Wetted End .....	32
 Nozzle Loading Criteria .....	 34
 Magnet Torque Table.....	 35

## WARNING: WHEN WORKING ON MAGNETICALLY DRIVEN PUMPS

- ◆ Strong magnetic fields may damage watches, credit cards, computers, computer tablets, cell phones and other electronic equipment when these are exposed to the magnetic fields of the exposed magnetic coupling components.
- People with pacemakers should be cautioned that the strong magnetic field may upset the timing or cause the pacemaker to malfunction.
- ◆ When working on the pumps, be aware that tools or metal parts brought within close proximity to the magnets may suddenly be attracted trapping fingers in the process.

## OPERATING INSTRUCTIONS MAXP ANSI PUMPS

This instruction manual is intended to assist those responsible for the installation, operation and maintenance of **MAGNATEX** Magnetic Drive Sealless Pumps. We recommend thoroughly reading this manual and reviewing the Hydraulic Institute Standards regarding Horizontal Centrifugal Pump installation before installing and operating your pump.

### **RECEIPT OF EQUIPMENT**

- A. Prior to uncrating, check for physical damage to the pumping system and notify the common carrier **IMMEDIATELY** if any damage is found.
- B. Check the nameplate on the pump against receiving and purchase order documents to be sure that the correct size pump and materials of construction have been supplied. If a motor has been supplied, check for correct horsepower, speed, and voltage.
- C. Check to see if flange protectors are intact. If not, check for foreign objects which may have found their way into the pump casing through the flange openings.
- D. Check for free rotation of the pump. Remove the coupling guard and rotate the pump using the motor shaft flexible coupling. Only slight resistance should be felt. If the pump has heavy resistance, or if any noise is heard, call your MAGNATEX representative or **MAGNATEX PUMPS INC.** (713-972-8666).

## **STORAGE PROCEDURES**

As shipped, the pumps are suitable for short term storage only, ~3-6 months, and the pump unit should be stored indoors in a protected environment away from weather extremes. If long term storage is necessary before the pump will be put into operation, contact your local representative or **MAGNATEX PUMPS, INC.** for long term storage recommendations.

For maximum protection cover the pump with plastic or some other protective material. Motors should be greased and rotated by hand every three (3) months. Maintain pump nozzle flange covers in place until ready to install the pump.

Before start-up, refer to the section titled "Rotation Check and Start-Up" (page 6).

## **PUMP AND MOTOR ALIGNMENT**

MAXP flexible coupled pumps have been pre-aligned with the customer's motor (where applicable) prior to shipment. Because pumps frequently receive rough treatment during shipment, they can become misaligned. To prevent inadvertent operation of a misaligned pump, the spacer coupling has been removed and packed separately with your shipment. The sleeve will need to be reinstalled and the coupling alignment checked prior to starting the pump. The spacer coupling is not designed to compensate for misalignment. Improper alignment will cause vibration and premature bearing failure.

## **FOUNDATION**

The foundation should be firm and heavy to reduce vibration and prevent flexing which can result in misalignment. A concrete foundation with a solid baseplate is recommended. Foundation bolts of the correct size should be located by reference to certified drawings if the baseplate is supplied by **MAGNATEX**. A final alignment check should be made after the baseplate has been grouted and set, and the foundation bolts have been tightened.

## **LOCATION & PIPING**

- A. Locate the pump as close as practical to the source of liquid supply.
- B. The suction line should be as short and straight as possible and contain a minimum number of elbows. Any elbows should be the large radius type. Elbows and fittings should be no closer than 10-20 pipe diameters to the pump suction to allow undisturbed flow to the pump impeller. The higher the velocity the greater the distance of straight pipe is needed.
- C. Generally, suction piping should be one or two sizes larger than the pump suction to keep friction losses to a minimum. This becomes more important as the distance between the pump and the liquid supply increases or similarly if piping fittings/connections are located closer than 10-20 pipe diameters to the pump's suction; see B above.
- D. The suction piping should have no high spots where air pockets can collect. All joints in the suction line should be tight to prevent air from entering into the system and creating the possibility of vapor locking. This is especially important when suction pressure is lower than the atmospheric pressure. A compound

pressure gauge should be installed in the suction line as close as possible to the suction flange.

- E. An air vent should be installed at the initial high point in the pump discharge line. A check valve and shut-off valve should be installed as close as possible to the pump discharge nozzle. The check valve is installed to protect the pump from excessive back pressure, including reverse flow / rotation, and back flow during shut down or driver failure. The discharge valve is located at the pump discharge to regulate flow and isolate the pump for servicing. A pressure gauge should also be installed on the discharge side of the pump as close as possible to the discharge nozzle between the pump and discharge valve.
- F. Prior to starting the pump it is important to flush the piping to insure the system is free of foreign matter and particles such as pipe scale, welding beads and dirt from system fabrication. Large particles can block the bearing lubrication ports in the pump causing serious damage. In addition, metallic particles can magnetically attach to the inner magnet also resulting in damage. If possible, a temporary startup strainer with a 40x40 US mesh screen should be installed in the pump's suction line. **BE VERY CAREFUL** not to allow the temporary strainer to be plugged to the point of starving the pump of liquid, resulting in cavitation and the possibility of running the pump dry. Since running the pump dry can destroy the pump's bearings, it is recommended to install a compound pressure gauge between the strainer and pump suction to monitor partial plugging of the strainer. The discharge pressure should also be closely monitored. Any drop in discharge pressure without discharge valve throttling could indicate partial strainer plugging (assuming constant demand to the system).
- G. Magnatex pumps, although very rugged, are not designed to handle excessive pipe stress. The resulting forces and moments on the pump can result in misalignment and possible damage to the pump. Piping must be anchored as close to, but independent from the pump. Pump and pipe flanges must be positioned together with gaskets (supplied by others) before attempting to tighten flange bolts. See Nozzle Loading Criteria, drawing ED-3603 on Page 34.
- H. The pump **MUST NOT RUN DRY**. To assure that adequate liquid is available to the pump suction, a flow sensor and /or power monitor should be installed to shut the pump down in the event of dry run. **MAGNATEX** provides an optional electronic power monitor offered at time of pump quotation to prevent dry run operation when properly installed and set according to the normal operating parameters of the pump.

### **RECOMMENDED A/F BEARING LUBRICANT, ROTATION CHECK, AND START-UP**

- A. Prior to starting the pump the bearing housing should be filled to the middle of the red dot on the oil gauge (item 90) with high quality turbine oil without additives from a major oil manufacturer of ISO Grade 68 lubrication oil (or equivalent). Synthetic oil of the same viscosity grade may be used if desired. Cooling fluid to the bearing frame taps is recommended for process pumping

temperature in excess of 350°F to extend service life. During normal operation maintain bearing oil temperature between 125°F and 150°F.

- B. Removal of air from the pump system is critical for proper system and component performance. Trapped air/vapor voids in the system piping can cause reduced discharge pressure readings and “choked” system flow. Safely vent all air/vapor from the system following best operational procedures.

Before the pump is placed in service check the direction of motor shaft rotation prior to connecting the pump and motor coupling halves with the removable flexible element and spacer flanges. Rotation should match the cast-in arrow or label and the direction of the casing scroll noted under the discharge flange. If the direction of rotation is incorrect, switch two of the three-phase power leads to the motor.

If the flexible element is installed and there is liquid in the system, then proceed as follows:

- A. Open the suction and discharge valve and allow the pump to be filled with liquid.

**!WARNING! NEVER RUN THE PUMP DRY**

- B. Remove the coupling guard for visual inspection of motor shaft rotation.
- B. Bump the motor by quickly pushing the motor start/stop buttons. Rotation should be clockwise as seen from motor end. If the direction of rotation is incorrect, reverse two of the three-phase power leads to the motor.
- C. After confirming proper rotation open the motor electrical disconnect and install the coupling flexible spacer element.
- D. Align the pump and motor to within ( $\leq$ ) 0.002” in all planes.
- E. Replace the coupling guard.

**PRIMING**

- A. Open the suction and discharge valves and allow the pump to fill with liquid. If the direction of rotation has not been checked, this must be done as detailed above under Rotation Check and Start-up before proceeding.

**!WARNING! NEVER RUN THE PUMP DRY**

- B. Close the discharge valve to 1/4 open.
- C. Start the motor and immediately check the discharge pressure gauge. The pressure should rise quickly and hold steady. If the pressure rises and then falls back, there is air or vapor in the system. STOP THE PUMP IMMEDIATELY. Wait 15 to 20 seconds before restarting the pump.
- D. If after repeating Step C several times, the pressure gauge does not hold steady or does not yield the expected pressure (from performance curve), contact your Magnatex representative, or **MAGNATEX PUMPS INC.** (713-972-8666) for assistance. Do not continue to operate the pump under these conditions.

- E. Once the pump is fully primed and the discharge pressure is steady, slowly open the discharge valve until the desired operating point is reached as referenced by discharge pressure reading and /or flow meter indication. The flow and head should match the design performance curve for the pump as ordered.

### **LUBRICATION OF PUMP PROCESS SIDE BEARINGS**

MAXP pumps have Silicon Carbide (SiC) hydrodynamic bearings on the process side of the pump that are internally lubricated by the pumped liquid. The pump must have liquid in it during operation to avoid damage and breakage of these product lubricated bearings. An optional material of SiC-X is available for enhanced resistance to lubrication and system upset conditions. Contact your Magnatex representative or **MAGNATEX PUMPS INC.** (713-972-8666) for more information.

### **SEPARATE FLUSH TO THE REAR CASING**

When the pump has been modified for a separate flush, the internal passage lubrication ports are plugged and the separate flush connection must supply liquid to the rear casing prior to starting the pump. OPERATING THE PUMP WITHOUT LIQUID SUPPLY TO THE REAR CASING CAN CAUSE IMMEDIATE SERIOUS DAMAGE.

Connect the separate flush piping to the ½" NPT flush connection located 90° to the right on the rear casing flange, as viewed from the pump suction end.

- A. Allow the rear casing to vent by removing the vent plug or opening the vent valve (if installed) located at the top left side of the rear casing flange, as viewed from the suction end. WARNING - The rear casing vent should be hard piped when handling toxic or hazardous liquids.
- B. Initiate flow to the rear casing through the separate flush piping. Allow the rear casing to fully vent. Turn the pump shaft by hand to expel any trapped air.
- C. Close the rear casing vent and maintain separate flush flow to the rear casing. Verify separate flush pressure is adequate by comparing the field reading to the minimum pressure specified by MAGNATEX on Diagram ED-3602 (Page 9).
- D. After the pressure check is satisfactory, open the suction and discharge valves to prime the pump as outlined in PRIMING (page 7).
- E. If possible, when the pump is operating, verify the separate flush flow rate is at or above the minimum flow specified by MAGNATEX (Diagram ED-3602). Record pressure readings and flow rates for future reference.

To drain the rear casing when using a separate flush, open the vent and remove the drain plug located at the bottom of the rear casing flange. The front casing may be drained through the plug at the bottom of the casing.



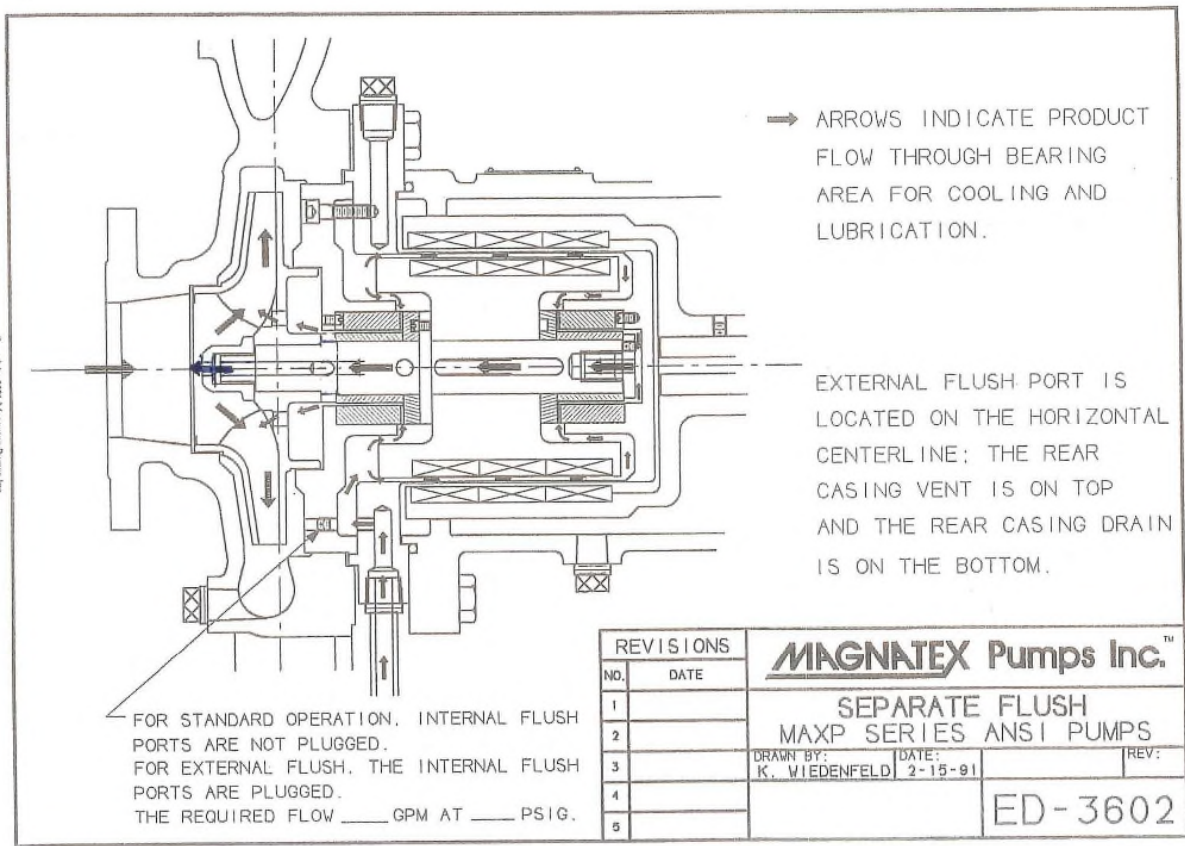

**OPERATIONS AND MAINTENANCE**

- A. Operators should make frequent visual inspections to insure the pump is running smoothly without noise or vibration, and that the discharge pressure is holding steady without fluctuation. Any excessive heating of the pump or motor bearings is cause for alarm. The unit should be shut down immediately, an investigation made to determine the cause, and corrective action taken.
- B. Follow the motor manufacturer's recommendations and keep the motor bearings lubricated properly.

**WARNING!** Never throttle the pump by closing the valve on the suction side of the pump. Throttling the suction side can cause serious damage to the pump. Throttle only from the discharge valve.

**WARNING!** Never operate the pump against a closed discharge valve for more than a few seconds. Low flow operation can cause rapid heating of the pumped liquid with possible vaporization and the pump bearings running dry, resulting in serious damage to the pump.

## **MAINTENANCE SCHEDULE**

<b><u>Part to be Inspected</u></b>	<b><u>Inspection Value</u></b>	<b><u>Frequency</u></b>
Bearing Housing	Fill with appropriate oil to the middle of the sight gauge as needed	Monthly
Change Oil in Bearing Housing	Drain old oil and fill with new fresh oil – consider oil analysis program	3000 Hours
Inner Magnet Sub-Assembly	Dismantle and check Thrust Rings, Sleeves, and Silicon Carbide Bushings for wear. Use new gaskets and O-rings upon reassembly.	Every 2 to 3 Years
Motor	As directed in the motor operations manual	As directed in motor manual

## **TORQUE CHECK**

To determine the static breakaway torque of the magnet coupling, place a torque wrench on the impeller nut and hold the outer pump shaft with a wrench. Use an initial torque wrench setting below the minimum torque value listed in the table on Page 1. Slowly turn the torque wrench counter-clockwise (CCW as seen from motor end) until the torque setting is reached or the magnets turn over (decouple).

Increase the torque wrench setting repeating in successive trials until the minimum torque value is reached or the magnets decouple. If the magnets decouple before the minimum value is reached, the inner magnet and possibly the outer magnet must be replaced.

The preferred method for checking the static torque value when the minimum magnet torque value is less than the impeller nut torque value is to leave the casing attached to the pump, then insert the torque wrench through the suction nozzle and turn the impeller nut in the CW direction (seen from the impeller side of the pump) with the shaft blocked against rotation. An alternate method is to remove the pump from the casing exposing the impeller for securing against rotation and turning the outer pump shaft at the coupling end to accomplish the torque check. In doing so a support should be placed under the frame adapter to brace the pump and the pump feet should be bolted or clamped against movement.

## **GENERAL NOTES**

- A. All inner magnets are marked "FRONT" to assist in correct position for reassembly. This marked end of the magnet must face the impeller of the pump.

- B. All casing covers and rear casings are marked "UP" on outer flange surface and utilize a rocker pin to assist in proper positioning.
- C. When accomplishing maintenance tasks and during reassembly, all threaded fasteners must be torqued in accordance with the torque table below.

**RECOMMENDED TORQUE VALUES  
FOR INTERNAL BOLTS AND SCREWS  
ALL MAXP SERIES (ANSI) PUMPS**

MODEL	<b>6</b> Impeller Nut (ft.lbs.)	<b>11</b> Impeller Nut Set Screw (in. lbs.)	<b>7</b> Sleeve Bolt (ft. lbs.)	<b>12</b> Sleeve Bolt Set Screw (in.lbs.)	<b>8</b> Hex Socket Head Bolt (in.lbs.)
AA6-F AA8-F AB6-F	72	14.4	33	5.2	106
A10-6-S A50-8-S A60-8-S A70-8-S A05-10-S A50-10-S	72	14.4	33	5.2	106
A60-8-M A70-8-M A05-10-M A50-10-M A60-10-M A70-10-M	72	14.4	72	5.2	106
A20-13-M A30-13-M	72	14.4	72	5.2	212
A50-10-L A60-10-L A70-10-L A75-10-L A85-10-L A40-13-L A80-13-L	173	14.4	173	14.4	212

# DISASSEMBLY AND REASSEMBLY

## F SIZE

### F25, F40, F65, F80

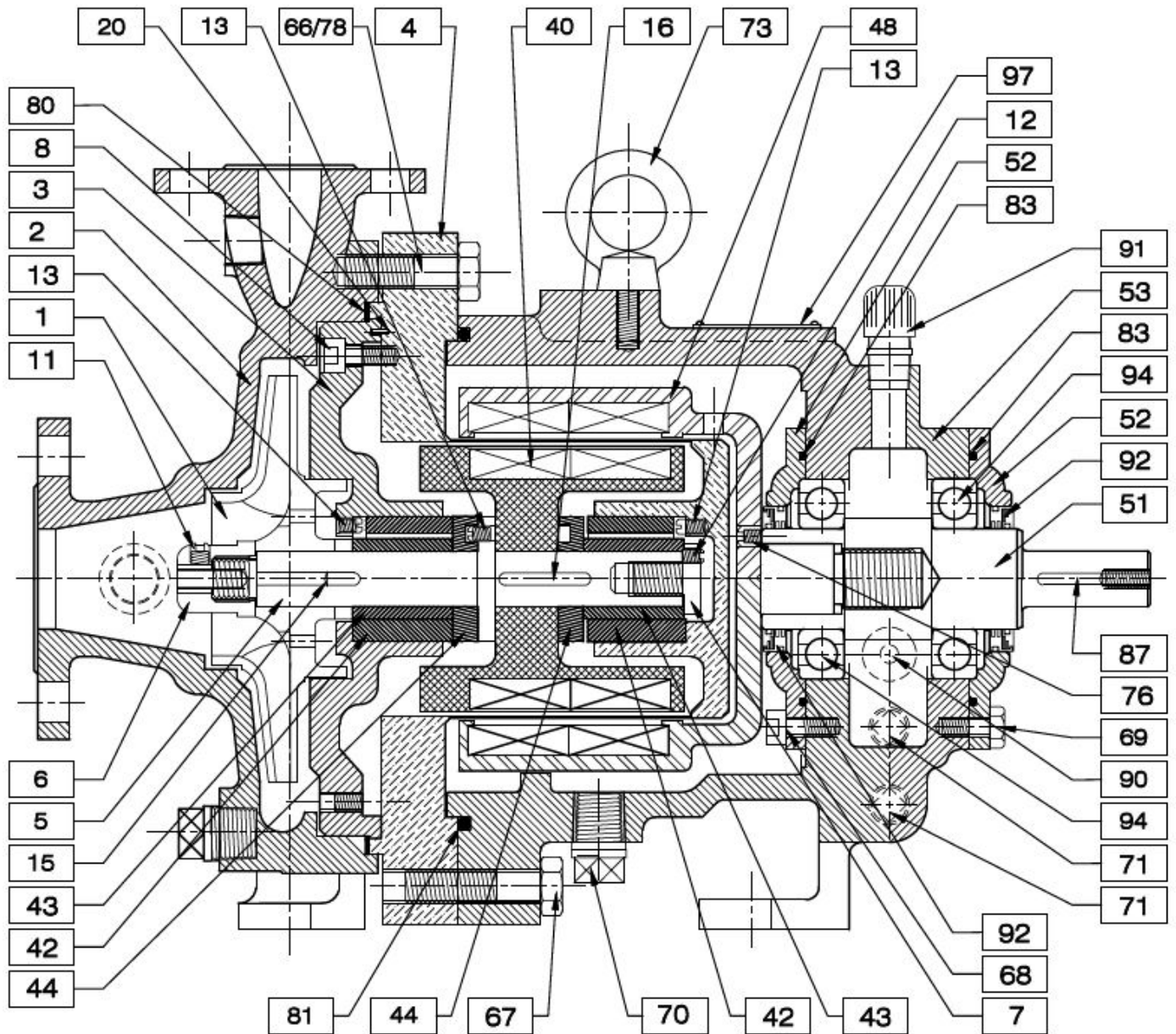

INNER FLUSH PLUGS AND FLUSH/VENT/DRAIN PLUGS  
USED ONLY WHEN OPTIONAL FA/D PORTS PROVIDED

PUMP CONSTRUCTION BEGINNING JANUARY 2016

ITEM	DESCRIPTION	QT	SPARE	MATERIAL
97	NAMEPLATE	1		304SS
94	BALL BEARING	2	2	NO. 6208
92	BEARING ISOLATOR - LABYRINTH SEAL	2	2	929360GTV
91	AIR VENT	1		Rc 3/8 AISI 304
90	OIL GUAGE	1		G 1/2 H.T.
87	MOTOR KEY 3/16 x 3/16 x 1.65	1		STEEL
83	O-RING G95	2		VITON
81	O-RING G190	1	1	VITON
80	GASKET 205x219x1.5t	1	1	PTFE
78	CASING HEX HEAD BOLT M12x75L	2		304SS
76	OUTER MAGNET SET SCREW M8x8L	1		STEEL
73	EYE BOLT M10	1		STEEL
71	BEARING HOUSING PLUG NPT 3/8	4		STEEL
70	FRAME ADAPTOR PLUG NPT 1/2	1		STEEL
69	HEX HEAD BOLT M8x15L	4		STEEL
68	SOCKET HEAD BOLT M8x15L	4		STEEL
67	HEX HEAD BOLT M12x45L	4		ASTM 283 GR. D
66	CASING HEX HEAD BOLT M12x45L	6		304SS
53	BEARING HOUSING, OIL: 0.1 L	1		D. IRON
52	BEARING COVER	2		D. IRON
51	SHAFT, OUTER MAGNET W/ KEY	1		STEEL
48	OUTER MAGNET	1		ASTM A575 1025
44	THRUST RING 443200	2	2	SIC
43	SLEEVE 433200	2	2	SIC
42	BUSHING 423200	2	2	SIC
40	INNER MAGNET	1		316SS
20	DOWEL PIN	1		316SS
16	INNER MAGNET KEY 5x5x36L	1	1	316SS
15	IMPELLER KEY 5x5x42L	1	1	316SS
13	SET BOLT M6x6L	3	3	316SS
12	SLEEVE BOLT SET SCREW M6x8L	1	1	316SS
11	IMPELLER NUT SET SCREW M8x8L	1	1	316SS
8	HEX SOCKET HEAD BOLT M8x25L	4	4	316SS
7	SLEEVE BOLT	1	1	316SS
6	IMPELLER NUT	1	1	316SS
5	SHAFT, INNER MAGNET W/KEYS	1	1	316SS
4	REAR CASING	1		316SS/HC
3	CASING COVER	1		316SS
2	CASING	1		316SS
1	IMPELLER	1		316SS

## **DISASSEMBLY OF WETTED END - F SIZE MAXP SERIES**

1. Remove the coupling guard and motor coupling.
2. Remove the casing drain plug (Item 14) and empty the pump of any remaining liquid. If the pump is being operated with a separate flush, remove the rear casing drain plug (Item 18) and rear casing vent (see page 8, SEPARATE FLUSH TO THE REAR CASING) to drain the pump.
3. Remove the 4 hex head bolts (Item 67) which holds the rear casing (Item 4) to the bearing housing.
4. Remove the 8 casing hex head bolts (Items 66 & 78) and the bolts attaching the bearing housing (Item 53) to the baseplate. The pump may now be removed leaving the casing attached to both the baseplate and piping.
5. Set the bearing housing so the motor shaft end is down. Brace the pump by positioning the shaft between supports for direct support to the bearing housing [Fig. 1]. Remove the gasket (Item 80).
6. Loosen the impeller nut set screw (Item 11) and remove the impeller nut (Item 6), the impeller (Item 1), and the impeller key (Item 15). An impact tool may be used for removal (only) of the impeller nut.
7. Place two M16 bolts (spaced at 180°) into the threaded ears of the bearing housing to jack the rear casing away from the bearing housing [Fig. 2]. Jack evenly to avoid binding between the rear casing and outer magnets.
8. After jacking is complete, pull the rear casing from the bearing housing. During this procedure remember that strong forces are working to keep the inner and outer magnets together. **BE CAREFUL TO AVOID TRAPPING YOUR FINGERS BETWEEN THE REAR CASING AND BEARING HOUSING.**
9. Remove the 8 hex socket head bolts (Item 8) on the rear casing cover (Item 3). Place the rear casing on its side for horizontal removal of the casing cover [Fig. 3].
10. Carefully lift off the casing cover (Item 3) as in Figure 3. Both the bushing (Item 42) and the sleeve (Item 43) are now loose and may come out with the casing cover. Since both parts may be damaged if dropped, be prepared to hold them as the casing cover clears the shaft.



Figure 1



Figure 2



11. Remove the bushing, sleeve, and thrust ring (Item 44).

12. Place the rear casing on its flat bottom and vertically lift out the shaft (Item 5) and inner magnet (Item 40). Be careful of the loose bushing located at the bottom of the rear casing (opposite shaft end) that may come out with the assembly.



Figure 3

13. Loosen the sleeve bolt set screw (Item 12) and remove the sleeve bolt (Item 7) [Fig. 4]. Remove the sleeve, the thrust ring, the inner magnet, and the inner magnet key (Item 16).

14. Remove the sleeve bolt by holding the inner magnet with the hand. DO NOT USE CHANNEL LOCKS OR A VISE ON THE INNER MAGNET to avoid damage.



Figure 4

### **DISASSEMBLY OF DRY END - F SIZE MAXP SERIES**

There are two methods for removing the dry end from the wetted end: shop removal and field removal. Shop removal is outlined on Page 14, DISASSEMBLY OF WETTED END F SIZE MAXP SERIES, procedures 1 through 8. Field removal is outlined below. This procedure is for dry end removal without wet end removal.

1. Remove the coupling guard and motor coupling.
2. Remove the 4 hex head bolts (Item 67) which anchor the bearing housing (Item 53) to the rear casing (Item 4), and the bolts which secure the bearing housing to the baseplate.
3. Place two M16 bolts (spaced at 180 degrees) into the threaded ears of the bearing housing to jack the rear casing away from the bearing housing. Jack evenly to avoid binding between the rear casing and outer magnet.
4. Pull the dry assembly away from the wetted assembly in one swift and steady motion. During this procedure remember that strong forces are working to keep

the inner and outer magnets together. **BE CAREFUL TO AVOID TRAPPING YOUR FINGERS BETWEEN THE REAR CASING AND BEARING HOUSING.**

5. When the dry end is separated from the wet end remove the outer magnet set screw (Item 76).
6. Remove the plug located on the right side (centerline) of the bearing housing, as seen from the motor end.
7. Rotate the outer magnet (Item 48) to align the hole in the outer magnet with the bearing housing hole. Place a rod through the bearing housing hole and the outer magnet hole to secure the outer magnet against turning. Turn the outer magnet shaft (Item 51) counter-clockwise from the motor end to unscrew the outer magnet and remove it from the housing.
8. Remove the 4 hex head bolts (Item 69) which secure the bearing cover (Item 52) on the motor side to the bearing housing. Remove the oil seal (Item 92) and the O-ring (Item 83).
9. Remove the 4 socket head bolts (Item 68) which secure the bearing cover on the pump side to the bearing housing. Remove the oil seal (Item 93) and the O-ring (Item 83).
10. Slide the outer magnet shaft (Item 51) and ball bearings (Item 94) out of the bearing housing from the motor end. Press off the two sets of ball bearings from the shaft.

### **ASSEMBLY OF DRY END - F SIZE MAXP SERIES**

1. Place a set of ball bearings (Item 94) on each side of the outer magnet shaft (Item 51) and press the bearings to meet the larger radius portion of the shaft. Slide the shaft and bearing assembly into the bearing housing (Item 53) so the keyed end faces the motor.
2. Insert the oil seal (Item 93) and the O-ring (Item 83) into a bearing cover (Item 52) and place it onto the pump side of the magnet shaft. Slide toward the bearing housing and bolt in place with the 4 socket head bolts (Item 68). Insert the oil seal (Item 92) and O-ring (Item 83) into the remaining bearing cover and slide it onto the motor side of the magnet shaft. Bolt in place with the 4 hex head bolts (Item 69).
3. Thread the outer magnet into the outer magnet shaft. To tighten, remove the plug located on the right side (centerline) of the pump, as seen from the motor end. Insert a rod through the hole and through the corresponding hole on the outer magnet. Turn the shaft clockwise (from motor end) to tighten.
4. Secure the outer magnet in place with the outer magnet set screw (Item 76).
5. Thread two M16 bolts into the threaded ears of the bearing housing. Place the O-ring (Item 81) into the bearing housing.



## **FIELD ASSEMBLY**

When the wetted end remains attached to the process piping, the following procedure should be used for assembling the dry end to the wetted end:

- A. Slide the dry end assembly over the rear casing until the two M16 bolts contact the rear casing flange. During this procedure remember that strong forces are working to pull the inner and outer magnets together. **BE CAREFUL TO AVOID TRAPPING YOUR FINGERS BETWEEN THE REAR CASING AND BEARING HOUSING.**
- B. Remove the two M16 bolts evenly to avoid binding between the rear casing and outer magnet. Bolt the bearing housing to the rear casing with the 4 hex head bolts.
- C. Add oil to the bearing housing through the air vent (Item 91) until the oil is to the center of the oil gauge (Item 90).

## **SHOP ASSEMBLY**

- A. Place the bearing housing in a vertical position with supports under the bearing housing. Do not stand the dry assembly on its outer magnet shaft.
- B. Lower the rotating assembly into the bearing housing until it rests on the two M16 bolts. Orientate the rotating assembly so the two internal flush holes (behind impeller) are aligned in a vertical position. During this procedure remember that strong forces are working to pull the inner and outer magnets together. **BE CAREFUL TO AVOID TRAPPING YOUR FINGERS BETWEEN THE REAR CASING AND BEARING HOUSING.** The assembly may be mechanically lowered by removing the impeller nut and threading on a M8 eye bolt.
- C. Remove the two M16 bolts evenly to avoid binding between the rear casing and outer magnet. Bolt the bearing housing to the rear casing with the 4 hex head bolts.
- D. Add oil to the bearing housing through the air vent (Item 91) until the oil is to the center of the oil gauge (Item 90).

## **ASSEMBLY OF WETTED END - F SIZE MAXP SERIES**

1. Place the inner magnet key (Item 16) onto the inner magnet shaft (Item 5). Slide the inner magnet (Item 40) onto the shaft from the sleeve bolt end (opposite end impeller). The embossed numbers on the magnet's end should face the motor (rear) side of the pump.
2. Slide the thrust ring (Item 44) onto the inner magnet shaft from the sleeve bolt end. The hole in the thrust ring should face the inner magnet and the notch should engage the inner magnet key.
3. Slide a sleeve (Item 43) over the inner magnet shaft and engage the remaining portion of the inner magnet key with the notch on the sleeve end.

4. Thread the sleeve bolt (Item 7) onto the inner magnet shaft. Tighten and secure with the sleeve bolt set screw (Item 12).
5. Thread a set bolt (Item 13) into the rear bearing holder. Carefully slide a bushing (Item 42) into the rear bearing holder and engage the set bolt with the notch on the bottom of the bushing.
6. Thread a set bolt (Item 13) into the shaft flange from the impeller end and tighten. Lift the inner magnet assembly by the shaft and slowly slide it into the rear casing [Fig. 5]. Be careful of the tight tolerances between the rear bushing and sleeve. This should only be done when the outer magnet is removed.
7. Slide a thrust ring onto the shaft so the hole engages the set bolt. Slide a sleeve onto the shaft so the notch is opposite the thrust ring.
8. Place the rear casing on its side for horizontal installation of the casing cover. Align the keyed portion of the inner magnet shaft with the notch in the sleeve. Insert the impeller key (Item 15) onto the shaft and engage the sleeve notch with the rounded end of the key.
9. Insert a set bolt (Item 13) into the front bearing holder on the casing cover (Item 3). Slide the other bushing into the bearing holder and engage the set bolt with the groove in the bushing.
10. Align the two flush holes vertically on the casing cover so the pin located on the VERTICAL POSITION of the rear casing flange engages the hole in the casing cover. Hold the loose bushing while sliding the casing cover over the shaft [Fig. 6]. Be careful of the tight tolerances between the bushing and sleeve.
11. Bolt the casing cover to the rear casing using the 8 hex socket head bolts (Item 8). Tighten evenly to avoid binding. Check for free rotation of the assembly.
12. Slide the impeller onto the shaft and thread on the impeller nut. Tighten and secure with the impeller nut set screw (Item 11) (This completes the rotating assembly).
13. Place the gasket (Item 80) onto the rotating assembly and bolt the rotating assembly to the casing (Item 2) with the 8 casing hex head bolts (Items 66 & 78). Tighten the bolts evenly to avoid binding.
14. Make a final inspection by turning the pump shaft and checking for free rotation and listening for noise. If resistance or scraping is felt, or if noises are heard (scraping, etc.), inspect the pump to determine the cause, and take corrective action.



Figure 5



Figure 6

# DISASSEMBLY AND REASSEMBLY

## M & S SIZE

### S25, S40, S65, S80

### M65, M80, M120

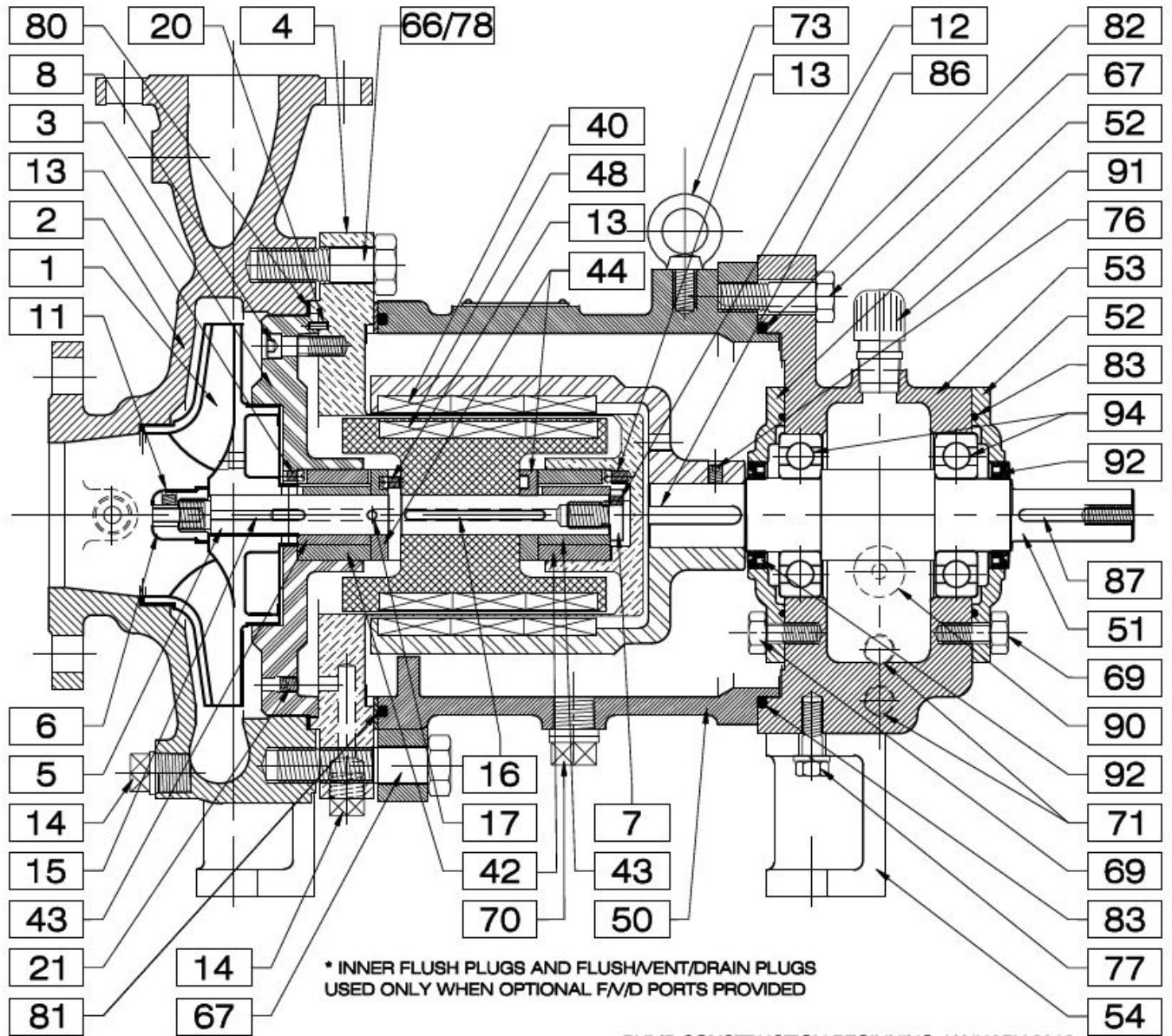

ITEM	QT	DESCRIPTION	MATL
94	2	BALL BEARING	No.6308
92	2	BEARING ISOLATOR - LABYRINTH SEAL	929360GTV
91	1	AIR VENT	Rc 3/8 AISI 304
90	1	OIL GUAGE	G 1/2 H.T.
87	1	MOTOR KEY .25 x .25 x 2.36	STEEL
86	1	OUTER MAGNET KEY 10 x 8 x 51L	STEEL
83	2	O-RING O105	VITON
82	1	O-RING O205	VITON
81	1	O-RING O210	VITON
80	1	GASKET 220 x 235 x 1.5t	PTFE
78	2	CASING HEX BOLT M16 x 80L -NOT SHOWN-	304SS
77	2	HEX HEAD BOLT M12 x 25L	STEEL
76	2	OUTER MAGNET SET SCREW M8 x 8L	STEEL
73	1	EYE BOLT M10	STEEL
71	3	BEARING HOUSING PLUG NPT 3/8	STEEL
70	1	FRAME ADAPTER PLUG NPT 1/2	STEEL
69	8	HEX HEAD BOLT M10 x 25L	STEEL
67	8	HEX HEAD BOLT M16 x 50L	ASTM 283 GR. D
66	8	CASING HEX HEAD BOLT M16 x 50L	304SS
54	1	SUPPORT	C.I.
53	1	BEARING HOUSING	D. IRON
52	2	BEARING COVER	D. IRON
51	1	SHAFT, OUTER MAGNET w/KEYS	STEEL
50	1	FRAME ADAPTER	D. IRON
48	1	OUTER MAGNET	ND / STL.
44	2	THRUST RING 444200	SIC
43	2	SLEEVE 434200	SIC
42	2	BUSHING 424200	SIC
40	1	INNER MAGNET	316SS
21	2	INNER FLUSH PLUG M8 x 8L (OPTION)*	316SS
20	1	DOWEL PIN	316SS
17	1	SLEEVE PIN Ø10 x 8L	316SS
16	1	INNER MAGNET KEY 10 x 8 x 77L	316SS
15	1	IMPELLER KEY 8 x 7 x 47L	316SS
14	4	DRAIN / FLUSH PLUG NPT 1/2 (OPTION)*	316SS
13	3	SET BOLT M6 x 6L	316SS
12	1	SLEEVE BOLT SET SCREW M6 x 8L	316SS
11	1	IMPELLER NUT SET SCREW M8 x 8L	316SS
8	8	HEX SOCKET HEAD BOLT M8 x 30L	316SS
7	1	SLEEVE BOLT	316SS
6	1	IMPELLER NUT	316SS
5	1	SHAFT INNER MAGNET w/KEYS	316SS
4	1	REAR CASING	316SS/HC
3	1	CASING COVER	316SS
2	1	CASING	316SS
1	1	IMPELLER	316SS

\* REFER TO DRAWING ED-3602 ON PAGE 9 OF THIS IOM MANUAL

## **DISASSEMBLY OF WETTED END – M & S SIZE MAXP SERIES**

1. Remove the coupling guard and motor coupling.
2. Remove the casing drain plug (Item 14) and empty the pump of any remaining liquid. If the pump is being operated with a separate flush, remove the rear casing drain plug (Item 18) and rear casing vent (see page 4, SEPARATE FLUSH TO THE REAR CASING).
3. Remove the 8 casing hex head bolts (Items 66 & 78) and the bolts attaching the bearing housing (Item 53) to the baseplate. The pump may now be removed leaving the casing attached to both the baseplate and piping.
4. Set the pump so the motor shaft end is down. Brace the assembly by positioning the shaft between supports for direct support to the bearing housing [Fig. 7]. Remove the gasket (Item 80).
5. Loosen the impeller nut set screw (Item 11) and remove the impeller nut (Item 6), the impeller (Item 1), and the impeller key (Item 15).
6. Remove the 4 hex head bolts (Item 67) which holds the frame adapter (Item 50) to the rear casing (Item 4).



Figure 7

7. Place two M20 bolts (spaced at 180 degrees) into the threaded ears of the frame adapter to jack the rear casing away from the frame adapter [Fig. 8]. Jack evenly to avoid binding between the rear casing and outer magnets.
8. After jacking is complete, pull the rear casing from the outer magnet. During this procedure remember that strong forces are working to keep the inner and outer magnets together. It may be helpful to thread a M8 eye bolt into the end of the inner magnet shaft and mechanically lift the rear casing from the outer magnet. BE CAREFUL TO AVOID TRAPPING YOUR FINGERS BETWEEN THE REAR CASING AND BEARING HOUSING.
9. Remove the 8 hex socket head bolts (Item 8) on the rear casing cover (Item 3). Place the rear casing on its side for horizontal removal of the casing cover.



Figure 8

10. Carefully slide off the casing cover (Item 3). Both the bushing (Item 42) and the sleeve (Item 43) are now loose and may come out with the casing cover. Since both parts may be damaged if dropped, be prepared to hold them as the casing cover clears the shaft [Fig. 9].
11. Remove the bushing, sleeve, and thrust ring (Item 44).



Figure 9



Figure 10

12. Place the rear casing on its flat bottom and vertically lift out the shaft (Item 5) and inner magnet (Item 40). Be careful of the loose bushing located at the rear casing support (opposite shaft end).

13. Loosen the sleeve bolt set screw (Item 12) and remove the sleeve bolt (Item 7) [Fig. 10]. Remove the sleeve, the thrust ring, the inner magnet, and the inner magnet key (Item 16).

## **DISASSEMBLY OF DRY END – M & S SIZE MAXP SERIES**

There are two methods for removing the dry end from the wetted end; Shop removal and field removal. For shop removal see page 22, DISASSEMBLY OF WETTED END – M&S SIZE MAXP SERIES, procedures 1 through 8. Field removal is outlined below. This procedure is for dry end removal without wet end removal. Remove the coupling guard and motor coupling.

1. Remove the 4 hex head bolts (Item 67) which anchor the frame adapter (Item 50) to the rear casing (Item 4). Remove the bolts which secure the bearing housing (Item 53) to the baseplate.
2. Place two M20 bolts (spaced at 180 degrees) into the threaded ears of the frame adapter to jack the rear casing away from the frame adapter. Jack evenly to avoid binding between the rear casing and outer magnet.
3. Pull the dry assembly away from the wetted assembly. During this procedure remember that strong forces are working to keep the inner and outer magnets together.
4. BE CAREFUL TO AVOID TRAPPING YOUR FINGERS BETWEEN THE REAR CASING AND FRAME ADAPTER.
5. Remove the 4 hex head bolts (Item 67) which attach the frame adapter to the bearing housing. Remove the frame adapter and O-ring (Item 82).



6. Loosen the two outer magnet set screws (Item 76) and slide off the outer magnet (Item 48). A mechanical pulling device may be helpful in removing the outer magnet.
7. Remove the 4 hex head bolts (Item 69) which secure the bearing cover (Item 52) on the motor end to the bearing housing. Remove the oil seal (Item 92) and the O-ring (Item 83).
8. Remove the 4 hex head bolts which secure the bearing cover on the pump end to the bearing housing. Remove the oil seal (Item 93) and the O-ring.
9. Slide the outer magnet shaft (Item 51) and ball bearings (Item 94) out of the bearing housing from the motor end. Press off the two sets of ball bearings.

### **ASSEMBLY OF DRY END – M & S SIZE MAXP SERIES**

1. Place a set of ball bearings (Item 94) on each side of the outer magnet shaft (Item 51) and press the bearings to meet the larger radius portion of the shaft. Slide the shaft and bearing assembly into the bearing housing (Item 53) so the smaller keyed end faces the motor.
2. Insert the oil seal (Item 93) and the O-ring (Item 83) into a bearing cover (Item 52) and place it onto the pump side of the magnet shaft. Slide toward the bearing housing and bolt in place with the 4 hex head bolts (Item 69). Insert the oil seal (Item 92) and O-ring (Item 83) into the remaining bearing cover and slide it onto the motor side of the magnet shaft. Bolt in place with the remaining 4 hex head bolts (Item 69).
3. Place the outer magnet key (Item 86) onto the outer magnet shaft and press on the outer magnet (Item 48). Secure the outer magnet with the two outer magnet set screws (Item 76).
4. Place the O-ring (Item 82) onto the frame adapter (Item 50) and slide the frame adapter over the outer magnet. Bolt the frame adapter to the bearing housing with the 4 hex head bolts (Item 67).
5. Bolt the support (Item 54) to the bearing housing.
6. Thread two M20 bolts into the threaded ears of the frame adapter. Place the O-ring (Item 81) onto the frame adapter.

### **FIELD ASSEMBLY**

When the wetted end remains attached to the process piping, the following procedure should be used for assembling the dry end to the wetted end:

- A. Slide the dry end assembly over the rear casing until the two M20 bolts contact the rear casing flange. During this procedure remember that strong forces are working to pull the inner and outer magnets together. **BE CAREFUL TO AVOID TRAPPING YOUR FINGERS BETWEEN THE REAR CASING AND FRAME ADAPTER.**

- B. Remove the two M20 bolts evenly to avoid binding between the rear casing and outer magnet. Bolt the frame adapter to the rear casing with the 4 hex head bolts (Item 67).
- C. Add oil to the air vent (Item 91) until the oil is to the center of the oil gauge (Item 90).

### **SHOP ASSEMBLY**

- A. Place the frame adapter in a vertical position with supports under the bearing housing. Do not stand the dry assembly on its outer magnet shaft.
- B. Lower the rotating assembly into the frame adapter until it rests on the two M20 bolts. Orientate the rotating assembly so the two internal flush holes (behind impeller) are aligned in a vertical position. During this procedure remember that strong forces are working to pull the inner and outer magnets together. BE CAREFUL TO AVOID TRAPPING YOUR FINGERS BETWEEN THE REAR CASING AND FRAME ADAPTER. The assembly may be mechanically lowered by removing the impeller nut and threading on a M8 eye bolt.
- C. Remove the two M20 bolts evenly to avoid binding between the rear casing and outer magnet. Bolt the frame adapter to the rear casing with the 4 hex head bolts (Item 67).
- D. Add oil through the air vent port (Item 91) until the oil is to the center of the red dot oil gauge (Item 90).

### **ASSEMBLY OF WETTED END – M & S SIZE MAXP SERIES**

1. Place the inner magnet key (Item 16) onto the inner magnet shaft (Item 5). Slide the inner magnet (Item 40) onto the shaft from the sleeve bolt end (opposite end impeller). The embossed numbers on the magnet's end should face the motor (rear) side of the pump.
2. Slide a thrust ring (Item 44) over the inner magnet shaft from the sleeve bolt end. The hole in the thrust ring should face the inner magnet and the notch should engage the exposed portion of the inner magnet key.
3. Slide a sleeve (Item 43) over the inner magnet shaft and engage the remaining portion of the inner magnet key with the notch on the sleeve end.
4. Thread the sleeve bolt (Item 7) into the inner magnet shaft. Tighten and secure with the sleeve bolt set screw (Item 12).
5. Thread a set bolt (Item 13) into the rear bearing holder. Carefully slide a bushing (Item 42) into the rear bearing holder and engage the set bolt with the notch on the bottom of the bushing.



6. Thread a set bolt (Item 13) into the shaft flange from the impeller end and tighten. Lift the inner magnet assembly by the shaft and slowly slide it into the rear casing [Fig. 11]. Be careful of the tight tolerances between the rear bushing and sleeve. This should only be done when the outer magnet is removed.

7. Slide a thrust ring onto the shaft so the hole engages the set bolt. Slide a sleeve onto the shaft so the notch is opposite the thrust ring.

8. Place the rear casing on its side for horizontal installation of the casing cover. Align the keyed portion of the inner magnet shaft with the notch in the sleeve. Insert the impeller key (Item 15) onto the shaft and engage the sleeve notch with the rounded end of the key.



Figure 11

9. Insert a set bolt (Item 13) into the front bearing holder on the casing cover (Item 3). Slide the other bushing into the bearing holder and engage the set bolt with the notch on the bushing end.

10. Align the two flush holes vertically on the casing cover so the pin located on the VERTICAL POSITION of the rear casing flange engages the hole in the casing cover. Hold the loose bushing in place while sliding the casing cover over the shaft. [Fig. 12].

11. Be careful of the tight tolerances between the bushing and sleeve.

12. Bolt the casing cover to the rear casing using the 8 hex socket head bolts (Item 8). Tighten evenly to avoid binding. Check for free rotation of the assembly

13. Slide the impeller onto the shaft and thread on the impeller nut. Tighten and secure with the impeller nut set screw (Item 11). (This completes the rotating assembly.)

14. Place the gasket (Item 80) onto the rotating assembly and bolt the rotating assembly to the casing (Item 2) with the 8 casing hex head bolts (Items 66 & 78). Tighten the bolts evenly to avoid binding.

15. Make a final inspection by turning the pump shaft and checking for free rotation and listening for noise. If resistance or scraping is felt, or if noises are heard (scraping, etc.), inspect the pump to determine the cause, and take corrective action.

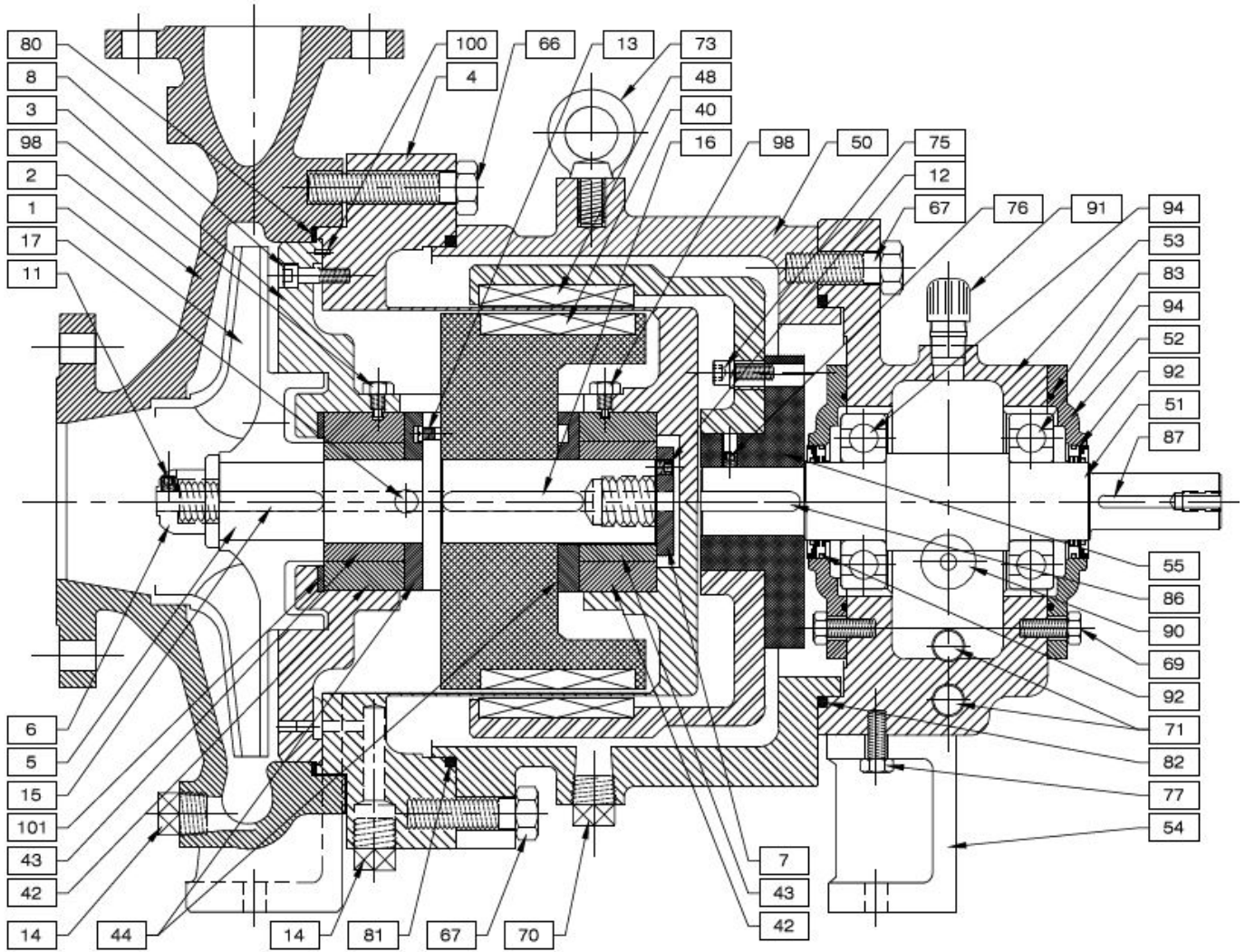

Figure 12

# DISASSEMBLY AND REASSEMBLY

## L SIZE

### L80, L120, L160



\*INNER FLUSH PLUGS AND FLUSH/VENT/DRAIN PLUGS  
USED ONLY WHEN OPTIONAL FV/D PORTS PROVIDED

PUMP CONSTRUCTION BEGINNING JANUARY 2016

ITEM	DESCRIPTION	MATERIAL	No.	REQ'D	REMARKS
			USE	SPARE	
101	CONICAL SPRING WASHER	AISI 316	1		
100	ROCK PIN	AISI 316	1		
98	SET BOLT	AISI 316	2		
94	BALL BEARING	ASTM A295 52100	2		No. 6308
92	BEARING ISOLATOR – LABYRINTH SEAL	PTFE/MTON O-RINGS	2	2	929360GTV
91	AIR VENT	Rc 3/8 AISI 304	1		
90	OIL GAUGE	RESIN	1		G 1/2 H.T.
87	MOTOR KEY	ASTM A575 1045	1		1/4x1/4x2.36"
86	OUTER MAGNET KEY	ASTM A575 1045	1		10x8x51L
83	O-RING	MTON	2		G105
82	O-RING	MTON	1		G200
81	O-RING	MTON	1	1	G260
80	GASKET	MTON	1	1	ø265x279x1.5t
77	HEX HEAD BOLT	ASTM A283 GRADE D	2		M12x25L
76	OUTER MAGNET SET SCREW	ASTM A29 4135	2		M8x8L
75	HEX SOCKET HEAD BOLT	ASTM A283 GRADE D	6		M12x35L
73	EYE BOLT	ASTM A668 CLASS C	1		M12
71	BEARING HOUSING PLUG	ASTM A74M Gr.35210	3		NPT 3/8
70	FRAME ADAPTER PLUG	ASTM A74M Gr.35210	1		NPT 1/2
69	HEX HEAD BOLT	ASTM A283 GRADE D	8		M10x20L
67	HEX HEAD BOLT	ASTM A283 GRADE D	8		M16x50L
66	CASING HEX HEAD BOLT	AISI 304	6		M16x75L
55	COUPLING BOSS	ASTM A575 1035	1		
54	SUPPORT	ASTM A48M CL.308	1		
53	BEARING HOUSING	ASTM A536 Gr.65	1		
52	BEARING COVER	ASTM A48M CL.308	2		
51	SHAFT, OUTER MAGNET W. KEYS	ASTM A575 1045	1		
50	FRAME ADAPTER	ASTM A575 GR.65	1		
48	OUTER MAGNET	ASTM A283 GRADE D	1		
44	THRUST RING	SiC	2	2	
43	SLEEVE	SiC	2	2	
42	BUSHING	SiC	2	2	
40	INNER MAGNET	AISI 316	1		
17	SLEEVE PIN	AISI 316	1	1	ø12x8L
16	INNER MAGNET KEY	AISI 316	1	1	12x8x73L
15	IMPELLER KEY	AISI 316	1	1	10x8x51L
14	DRAIN/ FLUSH PLUG*	AISI 316	3		NPT 1/2
13	SET SCREW	AISI 316	1	1	M8x12L
12	SLEEVE BOLT SET SCREW	AISI 316	1	1	M8x8L
11	IMPELLER NUT SET SCREW	AISI 316	1	1	M8x8L
8	HEX SOCKET HEAD BOLT	AISI 316	4	4	M10x20L
7	SLEEVE BOLT	AISI 316	1	1	
6	IMPELLER NUT	ACI-CF-8M	1	1	
5	SHAFT, INNER MAGNET W. KEYS	AISI 316	1	1	
4	REAR CASING	ACI-CF-8M	1		H-C SHELL
3	CASING COVER	ACI-CF-8M	1		
2	CASING	ACI-CF-8M	1		
1	IMPELLER	ACI-CF-8M	1		

## **DISASSEMBLY OF WETTED END - L SIZE MAXP SERIES**

1. Remove the coupling guard and motor coupling.
2. Remove the casing drain plug (Item 14) and empty the pump of any remaining liquid. If the pump is being operated with a separate flush, remove the rear casing drain plug (Item 18) and rear casing vent (see page 4, SEPARATE FLUSH TO THE REAR CASING).
3. Remove the 12 casing hex head bolts (Item 66 & 78) and the bolts attaching the bearing housing (Item 53) to the baseplate. The pump may now be removed leaving the casing attached to both the baseplate and piping.
4. Set the pump so the motor shaft end is down. Brace the assembly by positioning the shaft between supports for direct support to the bearing housing [Fig. 13]. Remove the gasket.
5. Loosen the impeller nut set screw (Item 11) and remove the impeller nut (Item 6), the impeller (Item 1), and the impeller key (Item 15).
6. Remove the 4 hex head bolts (Item 67) which holds the frame adapter (Item 50) to the rear casing (Item 4).



Figure 13



Figure 14

7. Place two M20 bolts (spaced at 180 degrees) into the threaded ears of the frame adapter to jack the rear casing away from the frame adapter [Fig. 14]. Jack evenly to avoid binding between the rear casing and outer magnets.

8. Thread a M10 eye bolt into the end of the inner magnet shaft and mechanically lift the rear casing away from the frame adapter [Fig. 15]. During this procedure remember that strong forces are working to keep the inner and outer magnets together. **BE CAREFUL TO AVOID TRAPPING YOUR FINGERS BETWEEN THE REAR CASING AND FRAME ADAPTER.**

9. Remove the 12 hex socket head bolts on the rear casing cover (Item 3). Place the rear casing on its side for horizontal removal of the casing cover.

10. Carefully slide off the casing cover. Since the sleeve (Item 43) is loose it may come out with the casing cover. Be prepared to hold the sleeve as the casing cover clears the shaft [Fig. 16].



Figure 16

11. Slide off the sleeve and thrust ring (Item 44). Remove the bushing set bolt (Item 19) and slide out the bushing (Item 42) and thrust washer (Item 22). The sleeve pin (Item 17) may also be removed if being replaced.

12. Place the rear casing on its flat bottom and thread the impeller nut onto the shaft. Carefully lift out the shaft and inner magnet assembly. You may wish to thread a M10 eye bolt into the shaft (instead of impeller nut) and mechanically lift out the shaft and inner magnet assembly.

13. Loosen the sleeve bolt set screw (Item 12) and remove the sleeve bolt (Item 7) [Fig. 23]. Remove the sleeve, the thrust ring, the inner magnet, and the inner magnet key (Item 16). Remove the bushing set bolt (Item 19) and slide out the remaining bushing.

14. Remove the sleeve bolt by holding the inner magnet with the hand [Fig. 17]. **DO NOT USE CHANNEL LOCKS OR A VISE ON THE INNER MAGNET.**

15. Remove the sleeve bolt by holding the inner magnet with the hand. **DO NOT USE CHANNEL LOCKS OR A VISE ON THE INNER MAGNET.**



Figure 15

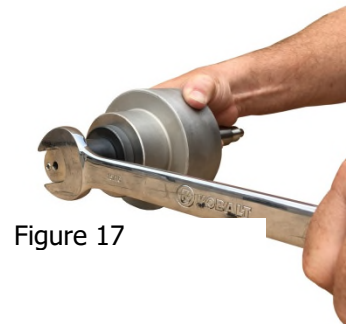

Figure 17



## **DISASSEMBLY OF DRY END - L SIZE MAXP SERIES**

There are two methods for removing the dry end from the wetted end: shop removal and field removal: Shop removal is outlined under "DISASSEMBLY OF WETTED END – L SIZE MAXP SERIES", procedures 1 through 8. Field removal is outlined below. This procedure is for dry end removal without wet end removal.

1. Remove the coupling guard and motor coupling.
2. Remove the 4 hex head bolts (Item 67) which anchor the frame adapter (Item 50) to the rear casing (Item 4). Remove the bolts which secure the bearing housing (Item 53) to the baseplate.
3. Place two M20 bolts (spaced at 180 degrees) into the threaded ears of the frame adapter to jack the rear casing away from the frame adapter. Jack evenly to avoid binding between the rear casing and outer magnets.
4. Pull the dry assembly away from the wetted assembly. During this procedure remember that strong forces are working to keep the inner and outer magnets together. **BE CAREFUL TO AVOID TRAPPING YOUR FINGERS BETWEEN THE REAR CASING AND FRAME ADAPTER.**
5. Remove the 4 hex head bolts (Item 67) which attach the frame adapter to the bearing housing. Remove the frame adapter and O-ring (Item 82).
6. Remove the six hex head bolts (Item 75) which secure the outer magnet (Item 48) to the coupling boss (Item 55). Slide off the outer magnet.
7. Loosen the two outer magnet set screws (Item 76) and slide off the coupling boss. A mechanical pulling device may be helpful. Remove the outer magnet key (Item 86).
8. Remove the 4 hex head bolts (Item 69) which secure the bearing cover (Item 52) on the motor end to the bearing housing. Remove the oil seal (Item 92) and the O-ring (Item 83).
9. Remove the 4 hex head bolts which secure the bearing cover on the pump end to the bearing housing. Remove the oil seal (Item 93) and the O-ring.
10. Slide the outer magnet shaft (Item 51) and ball bearings (Item 94) out of the bearing housing from the motor end. Press off the two sets of ball bearings.

## **ASSEMBLY OF DRY END - L SIZE MAXP SERIES**

1. Place a set of ball bearings (Item 94) on each side of the outer magnet shaft (Item 51) and press the bearings to meet the larger radius portion of the shaft. Slide the shaft and bearing assembly into the bearing housing (Item 53) so the smaller keyed end faces the motor.
2. Insert the oil seal (Item 93) and the O-ring (Item 83) into a bearing cover (Item 52) and place it onto the pump side of the magnet shaft. Slide toward the bearing housing and bolt in place with the 4 hex head bolts (Item 69).
3. Insert the oil seal (Item 92) and O-ring (Item 83) into the remaining bearing cover and slide it onto the motor side of the magnet shaft. Bolt in place with the 4 hex head bolts.
4. Place the outer magnet key (Item 86) onto the outer magnet shaft and press on the coupling boss (Item 55). Secure the coupling boss with the two outer magnet set screws (Item 76).
5. Slide the outer magnet (Item 48) onto the coupling boss. Bolt the outer magnet to the coupling boss with the 6 hex head bolts (Item 75).
6. Place the O-ring (Item 82) onto the frame adapter and slide the frame adapter over the outer magnet. Bolt the frame adapter to the bearing housing with the 4 hex head bolts (Item 67).
7. Bolt the support (Item 54) to the bearing housing.
8. Thread two M20 bolts into the threaded ears of the frame adapter. Place the O-ring (Item 81) onto the frame adapter.

## **FIELD ASSEMBLY**

When the wetted end remains attached to the process piping the following procedure should be used for assembling the dry end to the wetted end:

- A. Slide the dry end assembly over the rear casing until the two M20 bolts contact the rear casing flange. During this procedure remember that strong forces are working to pull the inner and outer magnets together. **BE CAREFUL TO AVOID TRAPPING YOUR FINGERS BETWEEN THE REAR CASING AND FRAME ADAPTER.**
- B. Remove the two M20 bolts evenly to avoid binding between the rear casing and outer magnet. Bolt the frame adapter to the rear casing with the 4 hex head bolts (Item 67).
- C. Add oil to the air vent (Item 91) until the oil is to the center of the oil gauge (Item 90).

## **SHOP ASSEMBLY**

- D. Place the frame adapter in a vertical position with supports under the bearing housing. Do not stand the dry assembly on its outer magnet shaft.

- E. Remove the impeller nut and thread an M8 eye bolt into the shaft end. Mechanically lower the rotating assembly (wetted end) into the frame adapter until it rests on the two M20 bolts. Orientate the rotating assembly so the two internal flush holes (behind impeller) are aligned vertically. Be careful of the strong magnetic forces which will pull the two assemblies together.
- F. Remove the two M20 bolts evenly to avoid binding. Bolt the frame adapter to the rear casing with the 4 hex head bolts (Item 67).
- G. Add oil to the air vent (Item 91) until the oil is to the center of the oil gauge (Item 90).

**ASSEMBLY OF WETTED END - L SIZE MAXP SERIES**

- 1. Place the inner magnet key (Item 16) onto the inner magnet shaft (Item 5). Slide the inner magnet (Item 40) onto the shaft from the sleeve bolt end (opposite end impeller). The embossed numbers on the magnet's end should face the motor (rear) side of the pump.
- 2. Slide a thrust ring (Item 44) over the inner magnet shaft from the sleeve bolt end. The hole in the thrust ring should face the inner magnet and the notch should engage the exposed portion of the inner magnet key.
- 3. Slide a sleeve over the inner magnet shaft and engage the remaining portion of the inner magnet key with the notch on the sleeve end.
- 4. Thread the sleeve bolt (Item 7) onto the inner magnet shaft. Tighten and secure with the sleeve bolt set screw (Item 12).
- 5. Carefully slide a bushing (Item 42) into the rear bearing holder. Align the notch on the bushing side with the hole in the bearing holder. Thread a set bolt (Item 19) into the bearing holder and engage the notch in the bushing.
- 6. Thread a set bolt (Item 13) into the shaft flange from the impeller end and tighten. Place the sleeve pin (Item 17) onto the shaft.

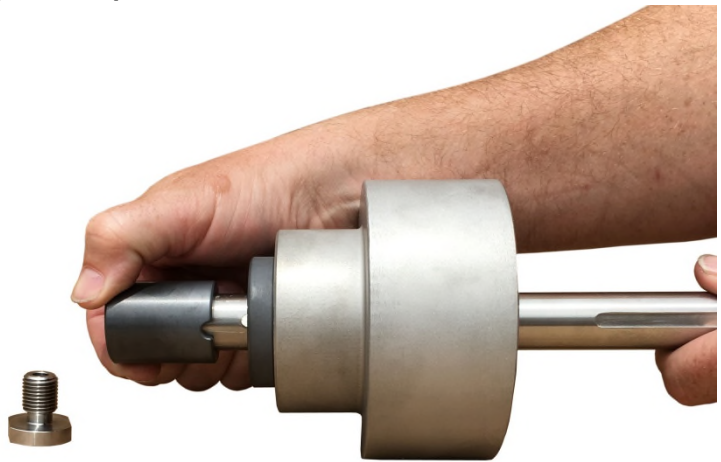

Figure 18



7. Thread on the impeller nut (Item 6). Lift the inner magnet assembly by the impeller nut and slowly slide it into the rear casing [Fig. 19]. You may wish to thread a M10 eye bolt into the shaft (instead of impeller nut) and mechanically lower the inner magnet assembly into the rear casing. Be careful of the tight tolerances between the rear bushing and sleeve. This should only be done when the outer magnet is removed.



Figure 19

8. Remove the impeller nut (or M10 eye bolt) and slide a thrust ring onto the shaft so the hole engages the set bolt. Slide a sleeve onto the shaft so the notch on the sleeve end engages the sleeve pin.

9. Place the thrust washer (Item 22) into the bearing holder on the casing cover (Item 3) and slide the other bushing into the bearing holder. Align the notch on the bushing side with the hole in the bearing holder. Thread a set bolt (Item 19) into the bearing holder and engage the notch in the bushing.

10. Place the rear casing on its side for horizontal installation of the casing cover. Align the two flush holes vertically on the casing cover so the pin located on the VERTICAL position of the rear casing flange engages the hole in the rear casing cover. Be careful of the tight tolerances between the bushing and sleeve.

11. Bolt the casing cover to the rear casing using the 12 hex socket head bolts (Item 8). Tighten evenly to avoid binding. Check for free rotation of the assembly.

12. Place the impeller key (Item 15) onto the shaft so the flat end of the key faces the impeller nut. Slide the impeller (Item 1) onto the shaft and thread on the impeller nut. Tighten and secure with the impeller nut set screw (Item 11). (This completes the rotating assembly.)

13. Place the gasket (Item 80) onto the rotating assembly and bolt the rotating assembly to the casing (Item 2) with the 12 casing hex head bolts (Items 66 & 78). Tighten the bolts evenly to avoid binding.

14. Make a final inspection by turning the pump shaft by hand and checking for free rotation and listening for noise. If resistance or scraping is felt, or if noises are heard (scraping, etc.), inspect the pump to determine the cause, and take corrective action.

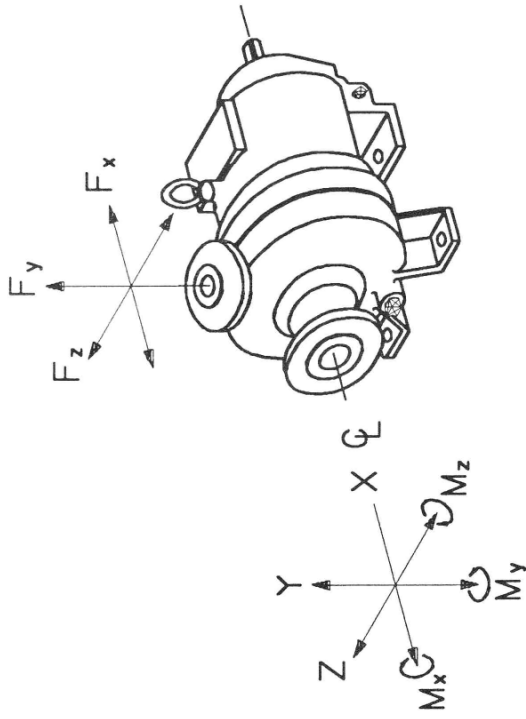

PUMP NOZZLE ANSI 150 lb. RF FLANGES	1"	1 1/2"	2"	3"	4"	6"	8"
	BENDING MOMENT	Mx ft-lbs 290	370	440	730	950	1670
	My ft-lbs 220	290	370	510	730	1310	1890
	Mz ft-lbs 150	190	220	370	510	870	1310
FORCE	Fx lbs 180	270	360	470	640	890	1280
	Fy lbs 140	200	250	310	400	620	820
SUCTION FLANGE	Fz lbs 140	220	290	400	510	710	1000
	Fx lbs 140	220	290	400	510	710	1000
FORCE	Fy(comp) lbs 180	270	360	470	640	890	1280
	Fy(tensile) lbs 90	140	180	240	320	440	640
DISCHARGE FLANGE	Fz lbs 140	200	250	310	400	620	820

REVISIONS		MAGNETEX Pumps Inc.™	
NO.	DATE		
1	10/07/92	NOZZLE LOADING CRITERIA	
2		ANSI 150 & 300 LB. RF FLANGES	
3		DRAWN BY: K. VIEDENFELD	DATE: 5-30-91
4		MAXP SERIES	
5		ANSI PUMPS	
		ED-3603	

COPYRIGHT 1991 MAGNETEX PUMPS INC.

# STATIC TORQUE TABLE

## MINIMUM TORQUE VALUES

### MAXP PUMPS

MAGNET SIZE	MINIMUM TORQUE IN LB-FT [Nm]	
1 pound force foot = 1.35 Newton meter	NEODYMIUM (Nd) Maximum Temp Limit 300°F [149°C]	SAMARIUM COBALT (SmCo) Maximum Temp Limit 750°F [400°C]
F25	15.85 [21.5]	15.85 [21.5]
F40	31.70 [43]	31.70 [43]
F65	62.06 [84.1]	52.84 [71.6]
S25	15.85 [21.5]	15.85 [21.5]
S40	31.70 [43]	31.70 [43]
S65	62.06 [84.1]	52.84 [71.6]
M40	41.71 [56.6]	31.70 [43]
M65	63.40 [86]	63.04 [86]
M80	84.54 [114.6]	63.40 [86]
M120	154.42 [209.4]	126.81 [171.9]
L80	211.35 [286.6]	158.51 [214.9]
L120	336.99 [456.9]	253.62 [343.9]
L160	422.70 [573.1]	317.02 [429.8]

**NOTES:**

1. When handling magnets refer to caution statements on page 2 of this IOM.
2. Rounding to the nearest whole number to obtain torque value is acceptable.
3. When torque test fails as outlined in Torque Check on page 10 of this IOM typically the inner magnet must be replaced. Inspect the Outer Magnet for loose damaged or magnets. Remove any attracted metallic objects from magnets using high strength tape by patting affected surfaces with the adhesive side.