

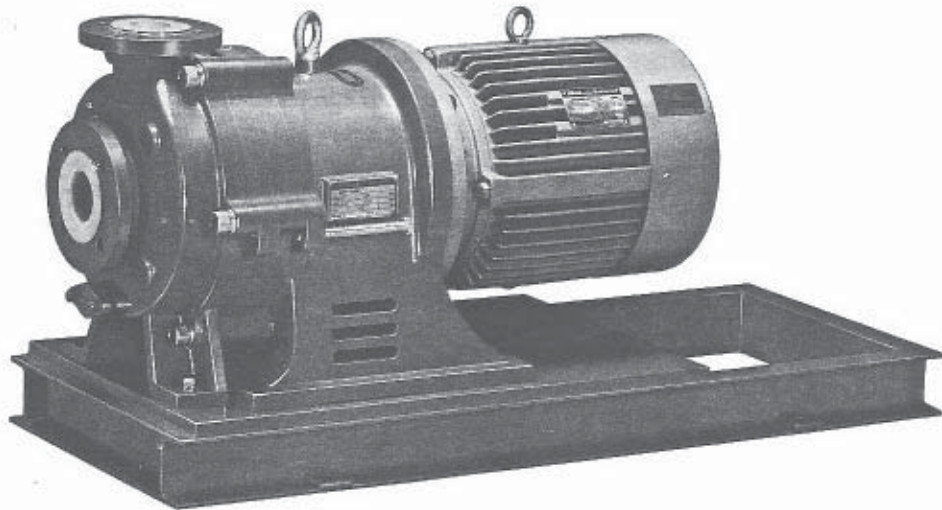

TEXEL®
TEFLON-PFA
MAGNETIC DRIVE PUMPS
MST SERIES



OPERATION AND MAINTENANCE MANUAL

Magnatex Pumps,
477 West 38th Street
Houston, TX 77018
Phone (713) 972-8666 Fax (713) 972-8665
www.magnatexpumps.com

!WARNING! - MAG DRIVE PUMP

DO NOT WORK ON THIS PUMP IF YOU ARE WEARING A MEDICAL DEVICE (DEFIBRILLATOR, PACEMAKER, ETC.) PERSONNEL WHO EXPERIENCE INTERFERENCE WITH THEIR MEDICAL DEVICE SHOULD MOVE AWAY FROM THE PUMP AND REFRAIN FROM HANDLING MAGNETIC PUMP COMPONENTS. SEEK IMMEDIATE MEDICAL ATTENTION IF YOU HAVE EXPERIENCED INTERFERENCE WITH YOUR MEDICAL DEVICE.

The rare earth permanent magnets in this pump have been manufactured such that the magnetic field is directional toward each half of the magnetic coupling. For this reason, the magnetic field that exists outside of the assembled magnetic coupling is minimal. When the two halves are apart, the magnetic field is exposed, which is why we recommend that personnel wearing medical devices DO NOT HANDLE the magnetic coupling components. When the pump is assembled, the magnetic fields from the magnetic coupling components are not exposed and it is safe for wearers of medical devices to be in the general proximity of the assembled pump, whether the pump is in operation or not.

1 Preface

Thank you for purchasing our Texel Magnetic Drive Pump, MT Series. The MT Series is a magnetic drive pump manufactured mainly with a combination of Teflon® PFA (Perfluoralkoxytetrafluoroethylene) resin and SiC (silicon carbide) ceramic. Displaying stability in the case of almost all chemicals and with almost no elution of metal ions, this pump is an ideal choice as a main process pump and also for applications involving the transfer of high purity chemicals. We suggest that you read this instruction manual carefully in order to ensure full understanding and correct handling of the MST Series.

2 Checking Points on Arrival

- (1) Does the nameplate correspond to what you ordered?
- (2) Are all the accessories supplied?
- (3) Have any components been damaged in transit?
Have any of the nuts and bolts become loose?
- (4) Can the motor be turned easily by hand? If heavy resistance is felt, or the motor does not turn at all, this means that the equipment has been damaged in shipping.

Contents

1. Preface	1
2. Checking Points on Arrival	1
3. Installation and Piping	1
4. Precautions for Operation	3
5. Maintenance Check	4
6. Disassembly and Assembly	5
7. Dry-Run Protector	9
8. Accident and Cause	11

3 Installation and Piping

(1) Installation

- ① Basically, the pump base should be installed on a concrete foundation. In the case that this is not possible, the base can be installed on a steel or wooden frame, but measures must be taken to prevent vibration during operation.
- ② When using a concrete foundation, place metal shims at four points between the concrete surface and lower surface of the base in order to level the pump. Then, fill the gaps with fine mortar so that the foundation and pump base are joined together as a single unit. (Fig. 1)

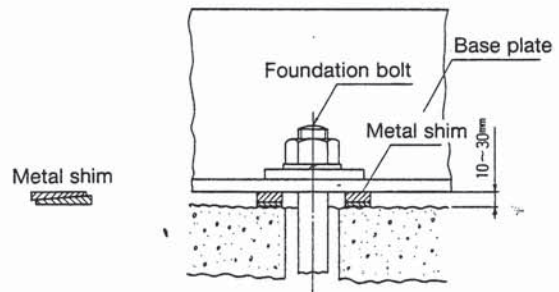

Fig. 1 Installation.

- ③ Place a level on the upper surface of the discharge flange of the pump, and, checking in both an axial direction and at right angles, adjust so that the level indicates a horizontal position.
- ④ Although there are no particular restrictions as regards where the pump can be installed, be it indoors or outdoors, select a place where inspection can be readily performed.
- ⑤ In the case of suction use, to determine the installation position (from the suction source to the suction head), take the NPSH into account. Further, even when the head is low, arrange the installation position to allow the suction piping to be as short as possible.

(2) Piping

① Suction Piping (Fig. 2)

- (i) Employ flange fittings as far as possible in order to avoid air leaks. Special care is required since it is extremely difficult to detect suction of air from the fittings.
- (ii) Adjust so that there is an upward incline from the suction side to the pump (approx. 1/50) in order to prevent air collecting in the piping. However, when using pressurized piping, install so that the incline faces downward toward the pump.
- (iii) Provide dustproof protection (screen) on the suction sump. Clean the suction sump thoroughly before filling with water.

- (iv) Install the end of the suction pipe deep enough to allow for lowered liquid levels.
- (v) Install a gate valve on the suction side in a horizontal position or facing downward in order to prevent accumulation of air. Be sure to keep the valve fully open except during inspection and replacement.
- (vi) Make the bend sections as gentle as possible and keep the number to a minimum. Further, do not install bend sections in close proximity to the pump inlet.
- (vii) When using specials, use an eccentric type in order to prevent accumulation of air.
- (viii) Since imbalance in the suction pressure may arise when the suction piping of a parallel operation pump is connected to a common base pipe, use independent suction piping.

Fig. 2 Suction Piping

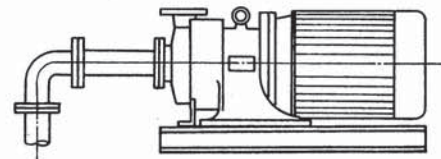
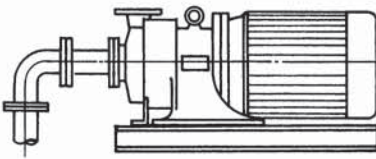
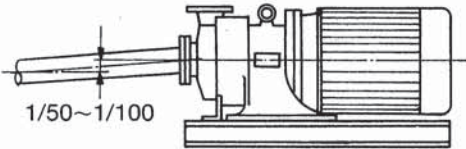
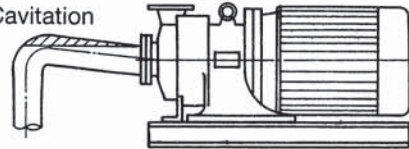
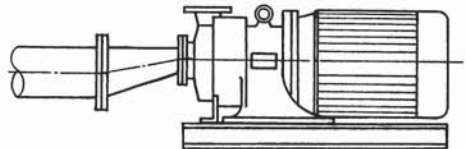
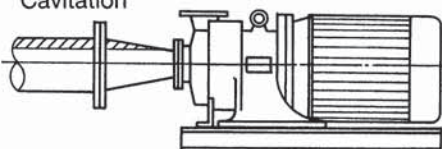
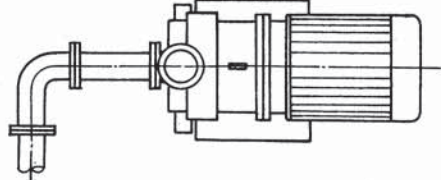
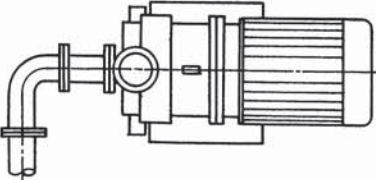
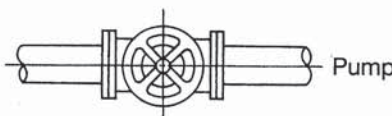
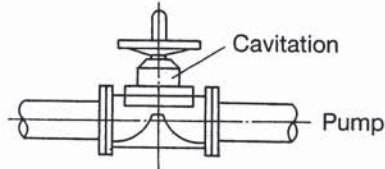
Correct	Incorrect
	
	
	
	
	

② Discharge Piping

- (i) The flow velocity of the discharge opening relates to the total pump head; set the nozzle diameter of the discharge piping so that the pressure loss will not exceed the prescribed value.
- (ii) Provide air vent valves where necessary since accumulation of air has adverse effects even when it occurs on the discharge side.
- (iii) When the discharge piping takes the form of a siphon, its highest part must not exceed the shutoff head of the pump.
- (iv) Install check valves to prevent reverse flow during pump shutdown and also to avoid water hammer when the actual pump head is high. And, since there is no means for air to escape during operation, provide air vents below the check valves. (Refer to the diagram below.)

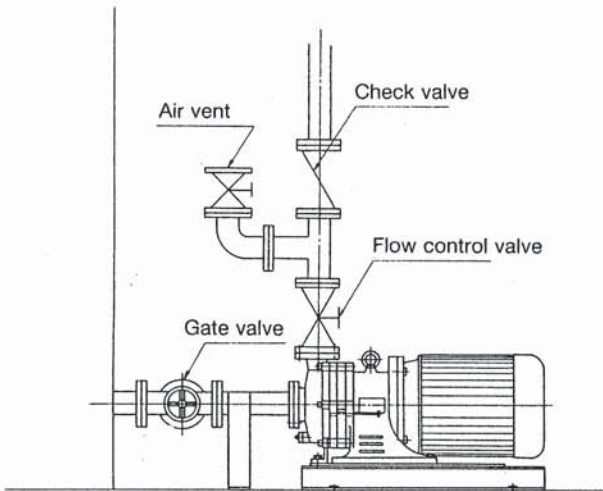

- ⑥ Start operation with the discharge valve fully closed.
- ⑦ When the rated rotation speed has been reached and after confirming that the pressure (shutoff pressure) has risen, open the discharge valve gradually and adjust until the specified discharge pressure has been reached.

(2) During Operation

- ① Noise Check
Sucking in of air or solids from the suction piping often gives rise to abnormal noise accompanied by vibrations.
- ② Vibration Check
Precautions are required in the case of vibrations caused by cavitation.
- ③ Be sure to adjust the discharge flow rate with the valve on the discharge side. Do not close the valve on the suction side.
- ④ Care should be taken in monitoring the discharge pressure, suction pressure, discharge flow rate, and electric current. When the discharge pressure fluctuates or falls abnormally, the cause can frequently be found in accumulation of solids on the suction side and sucking in of air, etc.

(3) Stopping Operation

- ① Under normal conditions, the discharge valve must be closed completely before stopping operation of the pump. If the suction valve is closed first, cavitation may result which can, in turn cause seizure of the pump, etc.
- ② When operating under pressurized conditions, close the suction valve after stopping operation.
- ③ When the pump stops due to a power failure during operation, first turn off the power switch and, at the same time, close the discharge valve manually.

(4) During Operation Shutdown

- ① In the case of a longterm shutdown, remove the liquid in the pump. Special care is necessary during the winter season since liquid left inside the pump may freeze, upon which it will expand causing cracks and other serious damage.

(5) Other Precautions

- ① Spare pumps should not be left unused for long periods of time, but utilized periodically to confirm that they are ready for use whenever the need may arise.
- ② Do not allow dry operation of the pump, even for a short period of time; dry operation may cause seizure of the sliding parts of the bushing, which are submerged in liquid. Further, never operate with the discharge valve fully closed (shutoff operation).
- ③ Use the specified discharge flow rate with the pump head. Do not use with an insufficient or excessive flow rate.
- ④ In the case that the pump is stopped following operation at a constantly high temperature, prior to recommencing operation, check for any looseness of the casing bolts (104-1); if looseness is observed, tighten all the bolts evenly according to the stipulated torque value.

4 Precautions for Operation

(1) Starting Up

- ① Rotate the motor manually and confirm that the motor turns without resistance.
- ② Clean inside of the suction piping, since dirt and scales, which may have entered the pipe during installation, can cause irreversible damage.
- ③ Confirm the rotation direction of the motor.
(Direction shown by arrow on casing cover.)
- ④ Do not fail to open the valve on the suction side pipe line fully.
- ⑤ Prime in order to replenish the pump completely with liquid. Use the discharge side piping for priming and expel air. When discharge of air presents difficulties, rotate the motor fan parts manually in the opposite direction and utilize the reaction; repeat this 4 or 5 times.

15 Maintenance Check

5.1 Daily Check

- (1) Liquid level of suction sump
- (2) Pump suction and discharge pressure
- (3) Current value and bearing temperature
- (4) Vibration and noise

5.2 Periodic Check

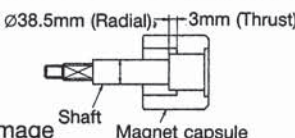
Parts	Check Points	Countermeasures / Replacement
Casing	<ul style="list-style-type: none"> ● Flaws on the lining surface, friction ● Dirt on the lining surface ● Gasket 	<ul style="list-style-type: none"> ● Replace if depth exceeds 4mm ● Clean ● Replace in case of permeation or deficient elasticity
Bushing Plate	<ul style="list-style-type: none"> ● Flaws on the lining surface, friction ● Dirt on the lining surface ● Extent of friction on bushing <ul style="list-style-type: none"> • Radial (Inside diameter) • Axial thrust load (Pad part) ● Dirt on sliding part of the bushing 	<ul style="list-style-type: none"> ● Replace if depth exceeds 4mm ● Clean <ul style="list-style-type: none"> • Replace if depth of cooling groove exceeds 1.5mm • Replace if depth of cooling groove exceeds 3mm ● Clean cooling groove
Spacer Plate	<ul style="list-style-type: none"> ● Flaws on the lining surface, friction ● Dirt on the lining surface ● Gasket 	<ul style="list-style-type: none"> ● Replace if depth exceeds 4mm ● Clean ● Replace in case of permeation or deficient elasticity
Impeller	<ul style="list-style-type: none"> ● Dirt between blades, contamination with foreign matter ● Clogging of balance hole ● Cracks on the insert 	<ul style="list-style-type: none"> ● Clean, remove ● Clean ● Replace if cracked
Rear Casing	<ul style="list-style-type: none"> ● Sliding of liquid contact parts and magnet capsule ● Dirt on liquid contact parts ● Flaws on inner or outer part ● Gasket 	<ul style="list-style-type: none"> ● If observed, confirm cause of bushing friction etc. ● Clean ● Use can be continued if flaws are superficial ● Replace in case of permeation or deficient elasticity
Shaft	<ul style="list-style-type: none"> ● Extent of friction <ul style="list-style-type: none"> • Radial • Thrust ● Surface cracks ● Screw part (Tightening of impeller nut) 	<div style="text-align: right;">  <p> $\varnothing 38.5\text{mm}$ (Radial), 3mm (Thrust) Shaft Magnet capsule </p> </div> <ul style="list-style-type: none"> ● Replace if cracked ● Depends on extent of damage
Magnet Capsule	<ul style="list-style-type: none"> ● Permeation ● Surface flaws ● Dirt on liquid contact parts ● State of installation with shaft 	<ul style="list-style-type: none"> ● If observed, replace according to degree of corrosion ● Replace cylinder part if depth of flaws exceeds 1.5mm and other parts if flaws exceed 3mm ● Clean ● Replace if looseness is observed
Impeller Nut	<ul style="list-style-type: none"> ● Degree of tightening with shaft ● Contact surface with locking part 	<ul style="list-style-type: none"> ● Replace if deficient ● Replace if locking part is defective
Outer Magnet	<ul style="list-style-type: none"> ● Sliding of rear casing ● Installation state of motor 	<ul style="list-style-type: none"> ● If observed, confirm cause ● If set screws are loose, tighten to set position

6 Disassembly and Assembly

6.1 Disassembly

1. Loosen and detach the 2 bracket fixing bolts (104-39) and the 6 casing bolt M16 screws (104-1).
2. Move the pump parts excepting the casing toward the rear together with the motor so as to face the working side.

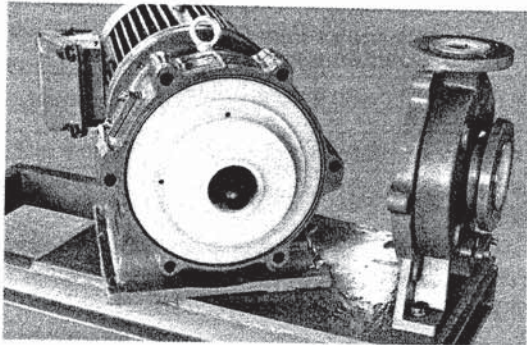

3. Insert the 2 disassembly/assembly bolts (104-58) into the bushing plate (054) and tighten them evenly. Then push the unit comprised of the impeller (013), bushing plate (054), magnet capsule (097), and shaft (018) toward the front.

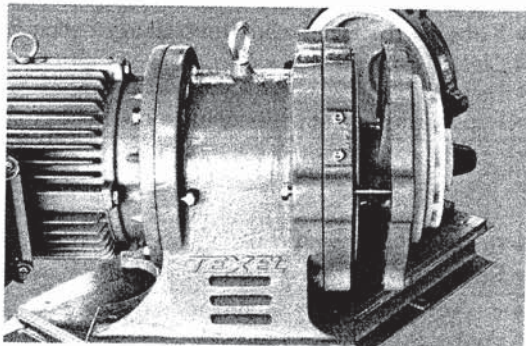

4. The suction force of the magnet coupling will have diminished; grasp the bushing plate with both hands and pull it out towards you. With the magnet capsule facing downwards, place the bushing plate on a sheet to ensure that it is not scratched.
5. The unit has now been removed, and the rear casing assembly (rear casing (060), spacer plate (096), rear casing plate (104), rear casing gasket (101-12) will be found set on the bracket (028).
Inspection can normally be carried out in this state.

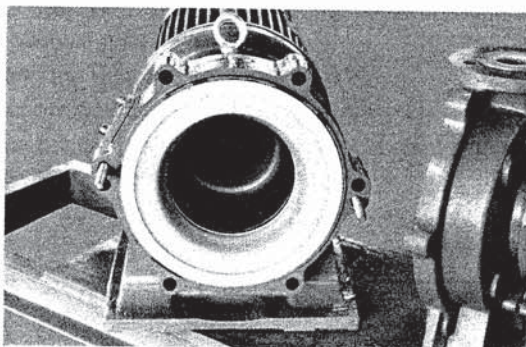

6. When detaching the rear casing assembly from the bracket (028), pull it out towards you in a straight line taking special care to see that the rear casing does not come in contact with the outer magnet (057).

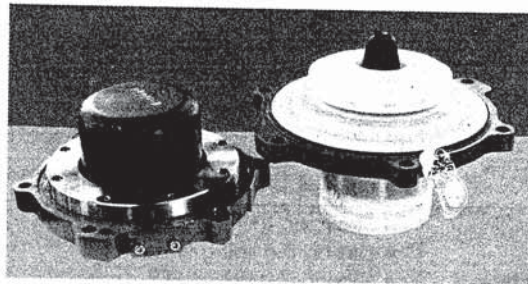

7. Hold the outer circumference of the impeller (013) in place with a belt wrench, etc., loosen the impeller nut (015) with a 36mm spanner and detach the impeller nut (015) and impeller (013) from the shaft (018).

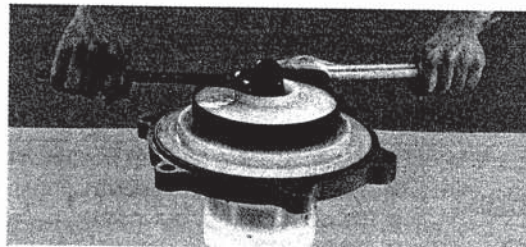

8. Detach the bushing plate (054) from the shaft (018).

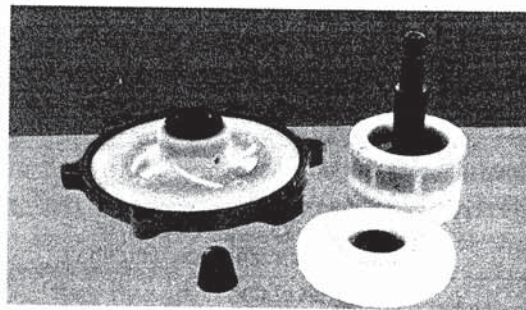

9. To further disassemble the rear casing assembly, by loosening and removing the 8 M8 screws, the rear casing (060), spacer plate (096), rear casing plate (104), and rear casing gasket (104-12) will come apart.



10. As show in the above photo, the unit and rear casing assembly will now be disassembled into individual parts.

6.1 Assembly

1. Insert the bushing plate (054) and impeller (013) in the magnet capsule (097) and shaft (018). Then use a belt wrench or 36mm spanner, etc. to tighten the impeller nut (015). The unit can be considered as complete once it has been confirmed that the impeller has been fixed firmly in place.
2. To assemble the rear casing, place the rear casing gasket (102-12) coated with Teflon paste and rear casing (060) on the spacer plate (096). Attach the rear casing plate (104) and tighten the 8 M8 screws evenly. The tightening torque is approximately 120~130kg/cm.

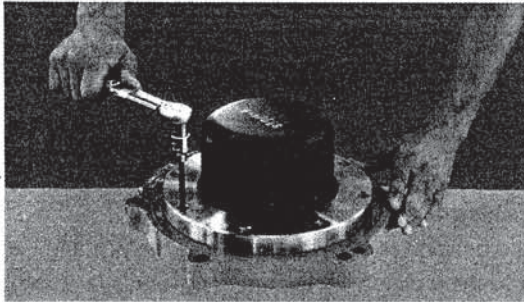

3. Attach the spacer plate (096) of the rear assembly by passing the disassembly/assembly bolts of the bracket (028) through the two guide holes. With the spacer plate (096) attached to the interlocking part of the bracket (028), rotate the motor fan manually to confirm that the cylinder part of the rear casing (060) and outer magnet (057) do not come in contact with each other.

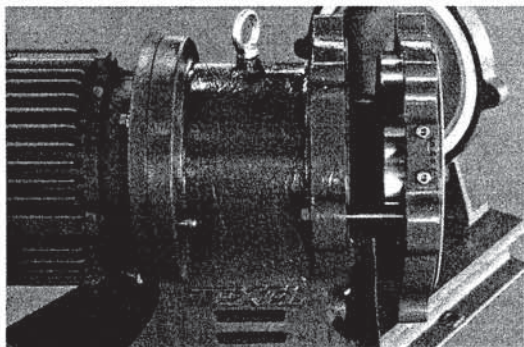

4. Using the outer circumference as a guide, attach the Teflon paste-coated bushing plate gasket (101-11) (with the same shape as the casing gasket (101-1)), to the spacer plate (096).
5. Insert the disassembly/assembly bolts, which have been disassembled, into the 2 guide holes in the bushing plate. Take adequate precautions to ensure that the unit does not fall off.

6. Loosen the disassembly/assembly bolts (104-58) evenly and set the magnet capsule (097) in its original position. Once installed, the suction force of the magnet coupling will be almost completely eliminated.

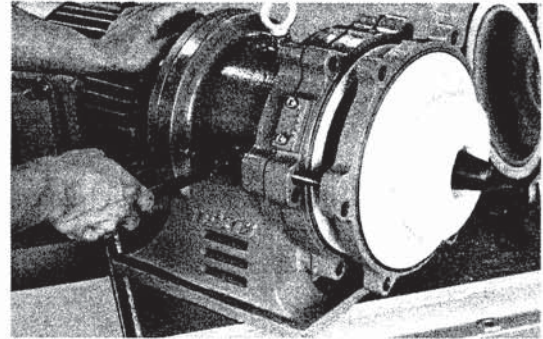

7. Using the cast metal part of the casing (001) as a guide, attach the periphery of the Teflon paste-coated casing gasket (101-1) to the casing (001). Then, align the unit consisting of the motor and bracket (028) with the casing (001). Pass the 6 casing bolts (104-1) through the holes in the bushing plate (096) and spacer plate (096) and tighten them evenly. At this stage, loosen the disassembly/assembly bolts (104-58) to the level of the bracket face and lower them toward the back. The tightening torque is 250~300kg/cm.

Finally, secure the base plate (067) with the bracket base bolts (104-39). To complete the assembly procedure, rotate the motor (fan) manually and confirm that it turns lightly.

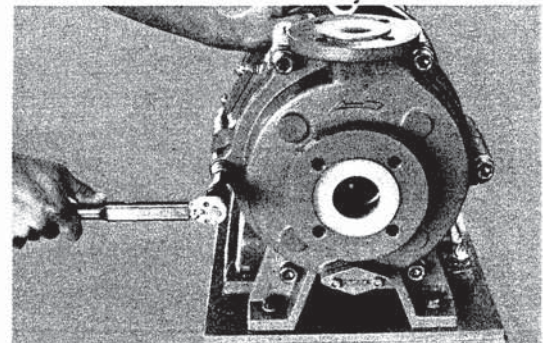

Detachment and Attachment of Motor

Detachment and attachment of the motor should be carried out with the pump part detached from the bracket (028).

Completely Assembled Product

(Precaution)

Tightening of the Casing and Rear Casing Plate Bolts

In order to ensure even tightening of the bolts, tighten them alternately in diagonal order little by little.

Tightening should be in accordance with the stipulated torque; however, if a bolt is tightened to the stipulated torque before going on to the next bolt, the degree to which the first bolt was tightened will diminish following tightening of the next bolt.

Accordingly, each bolt should be tightened the same amount in diagonal order a little at a time, this process being repeated until the stipulated torque is reached. Finally, a check should be made to confirm that each bolt has been tightened to the stipulated torque.

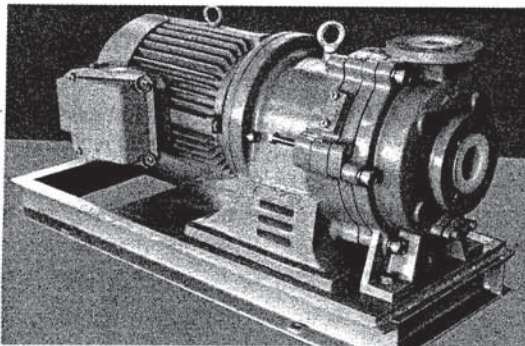

6.3 Shaft Installation

Fitting and disassembly of the shaft and magnet capsule can be made with either a hand press, air press, or hydraulic press. When removing the shaft from the magnet capsule, while taking special care with the screw part, fix the magnet capsule in place and push the head of the screw. In the case of installation, fix the magnet capsule in place, align the locking part, and push from the rear end of the shaft. The setting dimensions are indicated in the diagram below. The installation pressure shown on the gauge should be approximately $15\text{-}20\text{kg/cm}^2$.

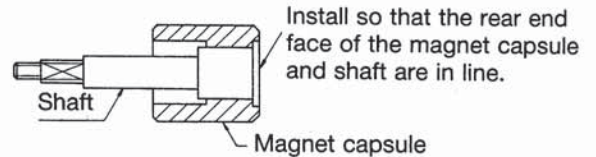

6.4 Bushing Installation

Align the position of the locking part of the bushing fixing hole on the bushing plate with the width across flats of the bushing, insert the jig in the bushing and using a resin hammer, press fit by tapping. When installing a SiC bushing, insert with special care.

Further, for the installation jig, a material such as rigid PVC etc. is suitable in order to avoid scratches and flaws on the bushing.

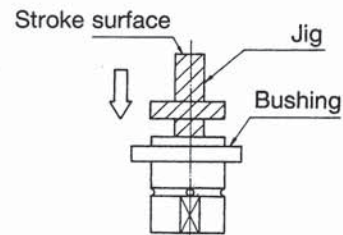

6.5 Outer Magnet Installation

The outer magnet is fixed to the motor shaft by tightening the set screws in 2 places. The setting dimensions are such that the outer magnet and the end face of the shaft are in line with each other, as shown in the diagram below.

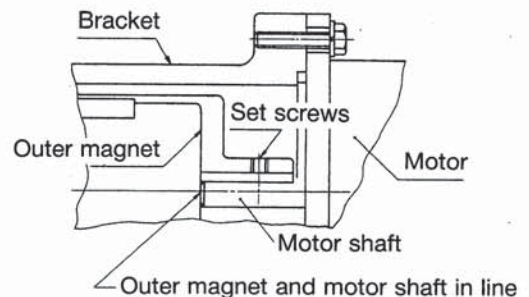

6.6 Disassembly Diagram and Parts List

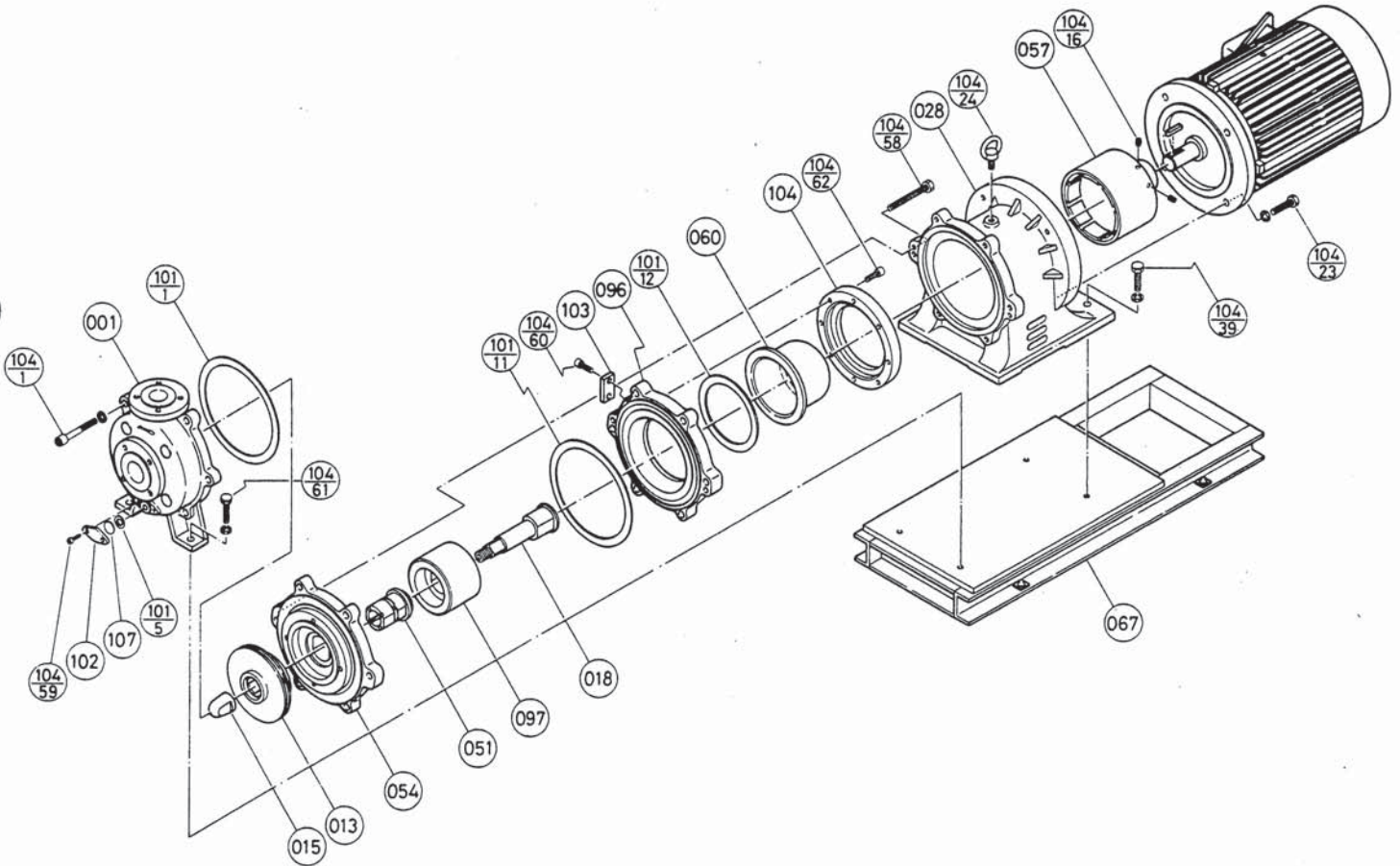

Parts List

Part No.	Part Name	Material	Q	Remarks
001	Casing	PFA + FCD 45 armor	1	
013	Impeller	PFA + SiC insert	1	
015	Impeller nut	PTFE	1	
018*	Shaft*	SiC	1	
028	Bracket	FC 25	1	
051*	Bushing*	PTFE filler/SiC	1	
054	Bushing plate	PFA + FCD 45	1	
057	Outer magnet	Rear earth	1	
060	Rear casing	SiC	1	
067	Base	SS41	1	
096	Spacer plate	PFA + FCD 45	1	
097	Magnet capsule	PFA	1	
101-01*	Casing gasket*	PTFE + non-asbestos	1	
101-05*	Drain gasket plate*	PTFE + non-asbestos	1	
101-11*	Bushing plate gasket*	PTFE + non-asbestos	1	
101-12*	Rear casing gasket*	PTFE + non-asbestos	1	
102	Drain flange	FC 25	1	

Part No.	Part Name	Material	Q	Remarks
103	Flushing flange	FC 25	1	
104	Rear casing plate	SUS 304	1	
104-01	Casing bolt	SUS 304	6	M12 x 130
104-16	Outer magnet set screw	SCM	2	M8: 3.7KW M10: 5.5~22KW
104-23	Motor bolt	SUS 304	4	M12: ~7.5KW M16: 11~22KW
104-24	Eye bolt	SS41	1	
104-39	Bracket base bolt	SUS 304	2	M12 x 40
104-58	Disassembly/assembly bolt	SUS 304	2	M12 x 110: 3.7KW M12 x 130: 5.5/7.5KW M12 x 145: 11~22KW
104-59	Drain flange bolt	SUS 304	2	M8 x 25
104-60	Flushing flange bolt	SCM	2	M8 x 16
104-61	Casing base bolt	SUS 304	2	M12 x 40
104-62	Rear casing plate bolt	SUS 304	8	M8 x 25
107	Gasket plate	PTFE	1	ø28 x t5

* Recommended spare parts for one year

Dry-Run Protector

The Texel Dry-Run Protector stops the pump immediately on detection of dry operation, thus preventing trouble before any real damage is caused.

Since this device is controlled by the motor current, extra installations on the piping are not required. Accordingly, no consideration need be given to either wiring from the pump to the operating device or to explosion proof measures in poor atmospheric conditions. The Dry Run Protector can be installed inside the operating device.

By setting the current value at a value selected when the pump has reached steady operation, i.e., when the discharge side is shut off, not only dry operation, but shut-off operation and cavitation can be prevented also.

Further by changing the current transformer and the number of current transformer turns in accordance with the pump capacity (motor capacity), the Dry Run Protector can be used with a motor of any capacity.

(1) Standard Specifications

Panel installation	
Power source	_____ AC100/200V 50/60Hz
Start-up time	_____ 30 sec. max. (Option of 5 sec. max. available)
Output contact	_____ 1C, content of contact: AC200V 3A
Fuse	_____ 1A
Power consumption	_____ approx. 2VA
Finishing color	_____ Munsell 7.5 BG5/4.5
Case material, weight	_____ ABS resin 300g (Does not include current transformer)

(2) Wiring

Connect one of the wires wired from the electromagnetic switch (magnetic contactor + thermal relay) to the motor to K and L on the current transformer where the specified coil has been prepared. Then connect the current transformer secondary terminals k and ℓ to the Dry Run Protector terminals k and ℓ .

For the supply voltage, select either 100V or 200V. Then connect contact point **b** (terminal marking: **b**) of contact point 1C with the exciting coil on the electromagnetic switch. Contact point **a** (terminal marking: **a**) of the output contact point can be used for external alarm circuits.

(3) Designation on Main Body Nameplate

CURRENT	: current setting dial
DELAY	: time setting dial
POWER	: power lamp (green)
ALARM	: alarm lamp (orange)
FACTOR	: current multiplying factor

(4) Operation Confirmation

Since the current differs according to the power required by the pump, set the current on-site by either reading the current with an ammeter when the pump is in a steady state, i.e., the discharge side is shut off, or, by obtaining the current value from the pump's performance curve. Note that it is safer to set the current value as close as possible to the value obtained when the pump is in a steady state, providing that the value determined does not constitute erroneous operation.

Time setting depends on the type of pump and service conditions; take into consideration the time taken for the pump to reach steady operation.

Once the current and time have been set, do not fail to confirm that the Dry Run Protector is operating properly. To do this, either shut off the discharge valve or create dry running conditions once the pump is operating steadily. A reset switch is provided in order to prevent careless turning on of the main switch when the pump has stopped as the result of dry operation, etc.

Accordingly, in the case that the pump has stopped due to malfunction, when recommencing operation following inspection, be sure to press the reset switch.

(Note) The multiplying factor for the current setting graduation differs according to the motor capacity.

(5) Use of Current Transformer

Refer to the table below to change the number of turns on the current transformer in accordance with the motor capacity. Also, pay attention to the current graduation multiplying factor.

Motor KW		Current Transformer Rating	Conductor Turns on Current Transformer	Current Transformer Graduation Multiplying Factor
200V	400V	(A)	(T)	(xA)
0.4	0.4, 0.75 1.5	5	—	1/2
0.75	—	10	10	—
1.5	—	10	10	—
2.2	2.2, 3.7	10	10	—
3.7	5.5	20	5	2
5.5	7.5	30	4	3
7.5	11	40	3	4
11	15, 18.5 22	50	2	5
15	30, 37 45	100	1	10
18.5	—	100	1	10
22	—	100	1	10
30	—	120	1	12

(6) Outline Drawing (Including installation dimensions)

① Main Body

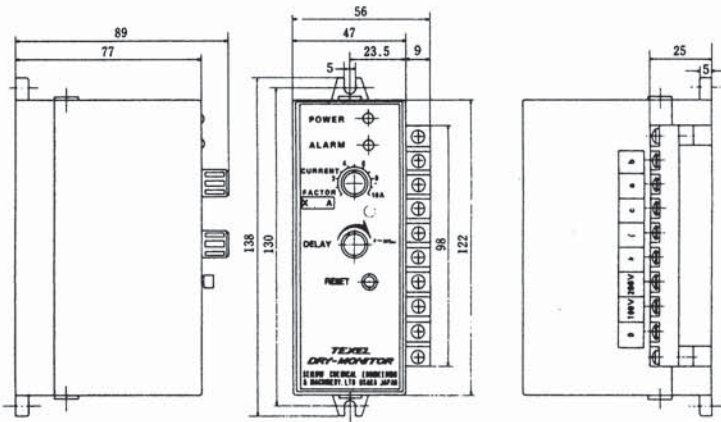

② Current Transformer

Motor: 0.75KW ~ (2.2kw ~)

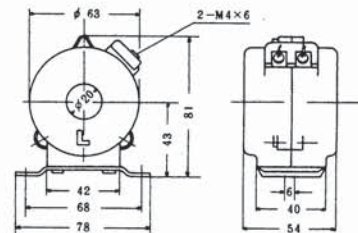

Motor: 0.4KW ~ (0.4kw ~ 1.5kw)

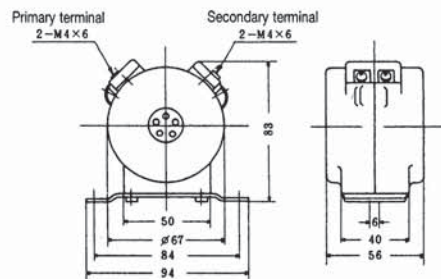

(7) Example of Circuit

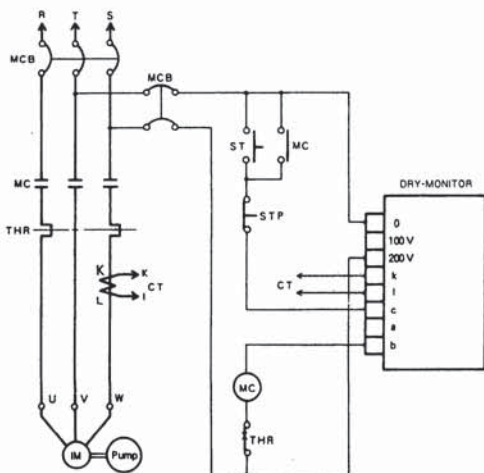

Symbol	Name	Symbol	Name
MCB	Magnet Circuit Breaker	ST	Start Switch
MC	Magnet Contactor	STP	Stop Switch
THR	Thermal Relay	CT	Current Transformer

8 Accident and Cause

