

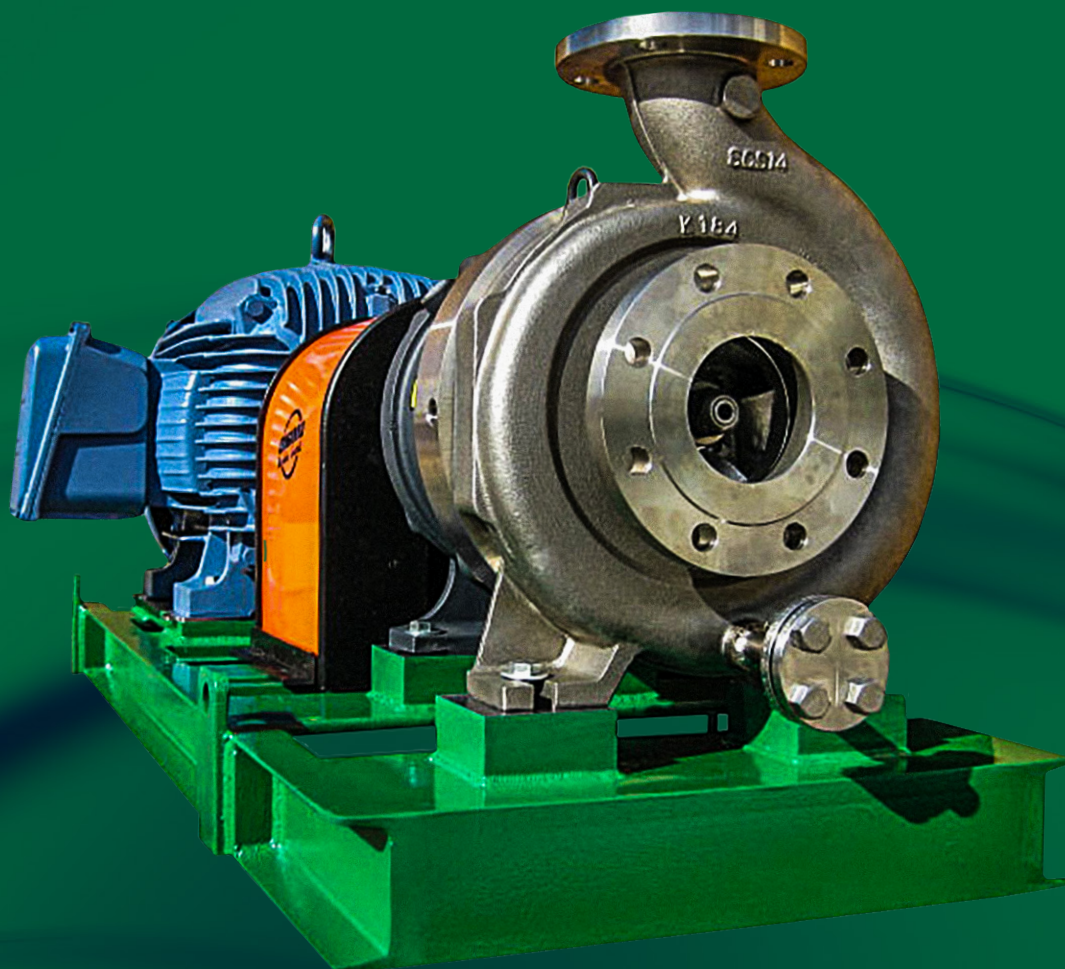

**Your Process Reliability &
Profitability is our #1 Priority**



www.MagnatexPumps.com

SEALLESS METALLIC CENTRIFUGALS



MAXP Series ANSI Magnetic Drive

Max. Flow: 2000 GPM
Max. Head: 470 Feet
Temperature: -150°F to 800°F
Max. Power: 200 HP
Materials of Construction:
304SS, 316SS, Duplex Stainless Steel,
Alloy 20, Alloy B&C, Monel, Titanium
Bearings: SiC, SiC-X



MPL/MHL/MLL Series Close Coupled ANSI Dimensional Pumps Magnetic Drive

Max. Flow: 340 GPM
Max. Head: 400 Feet
Temperature: -112° to 660°F
Max. Power: 20 HP
Materials of Construction: 316SS,
Alloy 20, Alloy B&C
Bearings: SiC, SiC-X



MP/MPH/ML Series Sub-ANSI Pumps Magnetic Drive

Max. Flow: 150 GPM
Max. Head: 190 Feet
Temperature: -112° to 660°F
Max. Power: 5 HP
Materials of Construction: 316SS,
Alloy 20, Alloy B&C
Bearings: SiC, SiC-X



MMP/MMH/MML Series Magnetic Drive

Max. Flow: 20 GPM
Max. Head: 95 Feet
Temperature: -112° to 536° F
Max. Power: 3/4 HP
Materials of Construction: 316SS, 304SS
Bearings: SiC-X
Shaft: 316SS, SiC



MPT Series Magnetic Drive

Max. Flow: 40 GPM
Max. Head: 440 Feet
Temperature: -22°F to 445°F
Max. Power: 20 HP
Materials of Construction: 316SS, Alloy 20
Bearings: SiC-X

SEALED CENTRIFUGAL



3596 Series ANSI Mechanical Seal

Max. Flow: 7500 GPM
Max. Head: 720 Feet
Temperature: up to 700°F
Max. Power: 300 HP
Materials of Construction:
Steel (DI upgrade), 316SS, CD4MCu,
CD4MCuN, Duplex/Super Duplex SS
(1B, 1C, 5A, 6A), Alloy B/C, Ni, Monel, Ti

SEALLESS, NONMETALLIC CENTRIFUGALS



MTA/MST Series ANSI Magnetic Drive

Max. Flow: 1450 GPM
Max. Head: 480 Feet
Temperature: Max. 330°F
Max. Power: 60 HP
Materials of Construction: PFA
Bearings: C-PTFE, SiC
Shaft: SiC



ME Series Magnetic Drive

Max. Flow: 90 GPM
Max. Head: 140 Feet
Temperature: 32°F to 195° F
Max. Power: 3 HP
Materials of Construction: ETFE Lined,
PVDF Lined
Bearings: C-PTFE, SiC
Shaft: Ceramic, SiC



MEP Series Magnetic Drive

Max. Flow: 106 GPM
Max. Head: 103 Feet
Max Temperature: 175° F
Max. Power: 5 HP
Materials of Construction:
GF Polypropylene
Bearings: C-PTFE, Carbon
Shaft: Ceramic

Custom engineered pumps are available for conditions that exceed the operating parameters outlined above.

SERVING GLOBAL MARKETS FOR OVER A QUARTER CENTURY

- Chemical Process
- Petrochemical
- Refining
- Water Treatment
- Food and Beverage
- Pulp and Paper
- Plating
- Pharmaceutical
- Semiconductor
- Power Generation
- Textiles
- General Industrial and OEM

Pumps for most process applications in a wide range of designs and materials

- Sealed and Sealless, Mag-drive, ANSI, sub-ANSI & ISO centrifugal pumps, as well as small gear-pumps
- Long and close-coupled pumps for NEMA or IEC motors



- Metallic – Ductile Iron, Steel, Stainless Steels, Alloy 20, Alloy B&C, Monel and Titanium
- Non-Metallic lined pumps – Polypropylene, PVDF, ETFE and PFA

Superior Straddled-mounted Design

Magnatex metal, mag-drive pumps feature a straddle-mounted inner magnet design that reduces radial shaft load when compared to our competitors' cantilevered models. This feature allows operation across the entire performance curve without compromising service life.

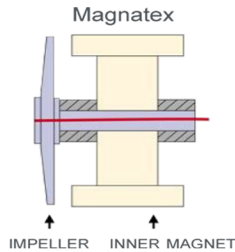

Smaller, sub-ANSI Pumps

For low flow applications, robust metal and non-metallic sub-ANSI models allow operation closer to the best efficiency point when compared to ANSI pumps, which reduces initial cost and total cost of ownership.

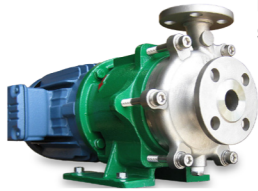

Innovative Solutions to Challenging Applications

High-pressure and high-temperature liquids, solids laden liquids, acids, bases, pyrophoric liquids and toxic liquids are just a few of the challenging liquids being successfully handled by Magnatex Pumps.

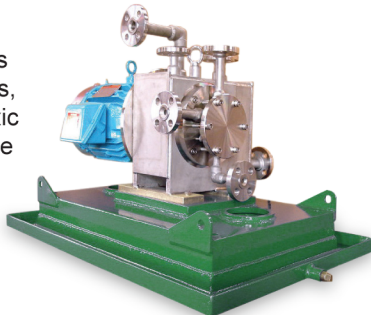

Enhanced Dry-running bearing system

Magnatex metal pumps now feature SiC-X bearing material as a standard on our smaller pumps or as an option on larger units. With a coefficient of friction 1/4 that of SiC, SiC-X provides extended dry-running capability during upset conditions. Non-metallic pumps also have optional bearing materials for challenging services.



Extremely cost-effective ANSI sealed pump alternatives

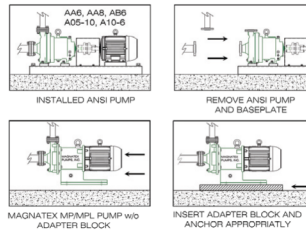

In addition to sealless, long-coupled ANSI units, close coupled models are available with flange locations identical to sealed ANSI pumps. This feature enables easy replacement of problem sealed pumps with Magnatex sealless mag-drive, metallic or non-metallic pumps.

Solids Handling

With multiple provisions for handling up to 8% or more solids, Magnatex can take on difficult process applications that other mag-drive pumps are unable to handle.

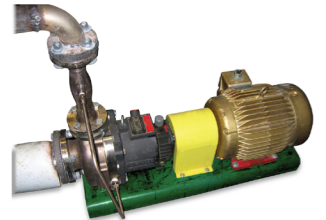

Quick Support and easy Field Maintenance



Slip-fit construction allows easy, onsite maintenance, if required. Additionally, Magnatex can inspect and repair any pump at our facility in Houston, TX. A worldwide network of distributors and representatives provide technical assistance and parts support 24/7.

Large Inventory

A multimillion dollar inventory enables same day shipment of pumps and parts in emergency situations, anywhere in the world.



Magnetic Drive Sealless Pumps

MAGNATEX[®] MMP Series

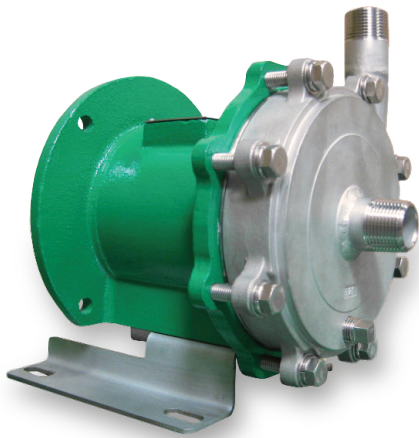

The MMP Series magnetically driven, sealless, centrifugal pumps are heavy-duty mag-drive pumps with superior SiC-X bearing materials for low flow applications. These close-coupled pumps are similar in construction to the MPL/MP Series, except the shaft is stationary and the suction/discharge ports are male NPT with optional flanges available.

The MMP Series pumps are high-quality, dependable, long-lasting, pumps utilizing our exclusive straddle bearing design and furnished with the shaft, thrust ring and bushing made of beta sintered silicon carbide material. Sealless pumps help eliminate "Reportable Release" issues.

All Magnetex[®] pumps and spare parts come with a 1-year unconditional warranty on materials and workmanship.

MAGNATEX[®] MMP Series Specifications

Maximum Flow	20 GPM
Maximum Head	95 FT
Liquid Temperature	-100° F to 536° F
Maximum Power	¼ HP
Connections	NPT or Optional Flanges
Bearings	SiC/SiC-X Standard
Working Pressure	85 psig
Impeller	Enclosed
Speeds	Up to 3550 rpm
Magnets	Neodymium
Motor	NEMA or IEC Frame Mounted

Materials of Construction:

- 316SS
- Ceramic or Stainless Steel Shaft Option



Optional high-pressure models for suction conditions to 5,000 psi and more.

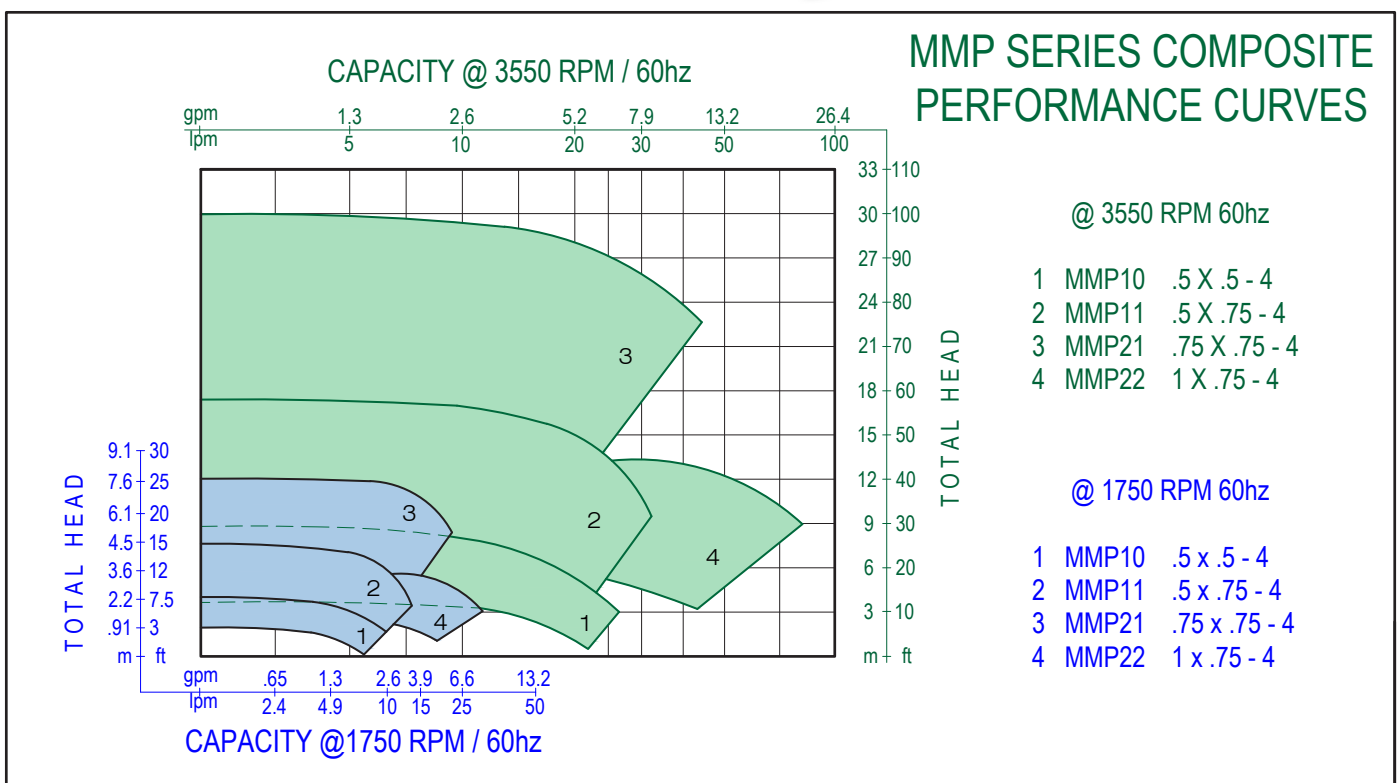

MAGNATEX® MMP Series Component View

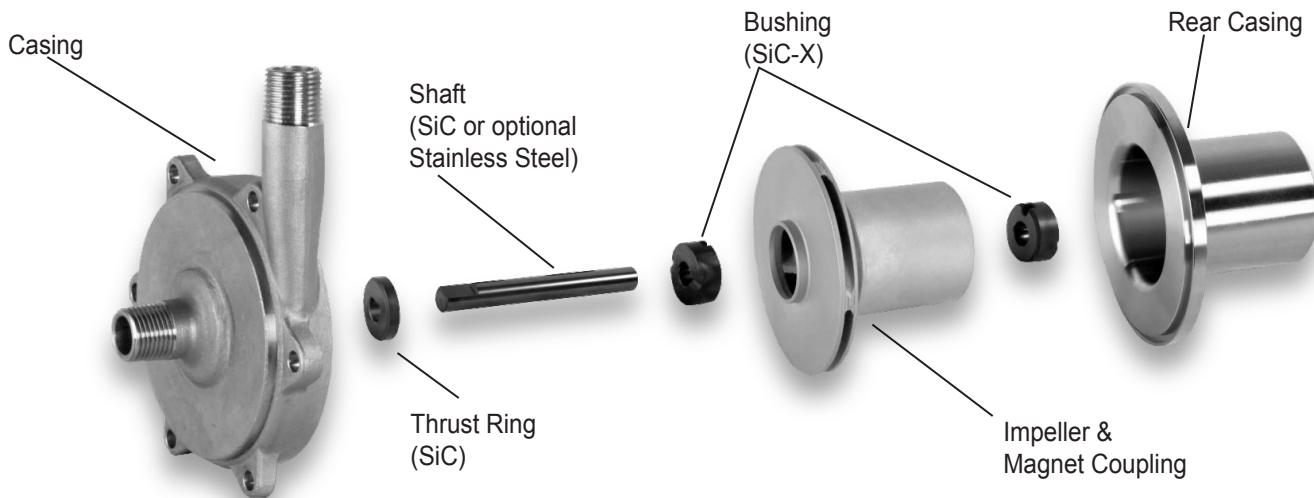

(Magnatex standard model shown)

Optional high-pressure models for suction conditions to 5,000 psi and more

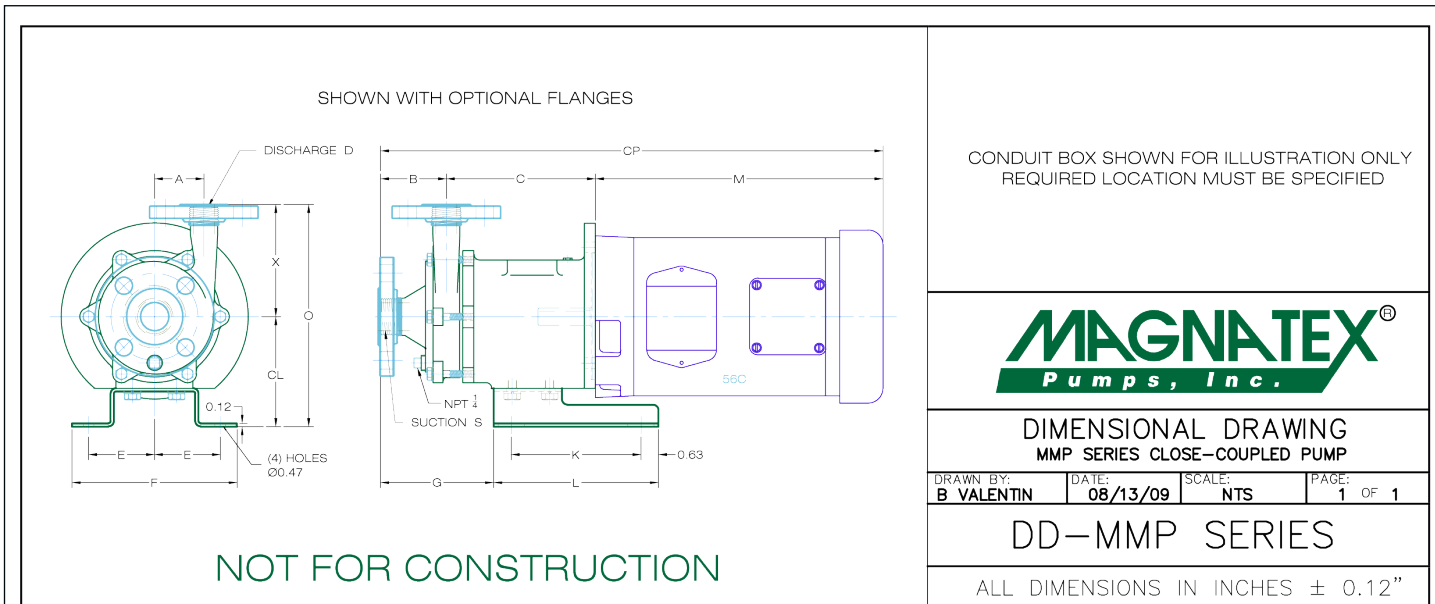

MODEL	MOTOR FRAME	DIMENSIONS										STANDARD NPT					* OPTIONAL 150# ANSI RF					APROX. WEIGHT lbs.	
		M	CP	B	C	E	F	G	K	L	CL	S	D	A	X	O	S	D	A	X'	O'	PUMP	MOTOR
MMP11	56 C	13.85 MAX	20.95	1.80	5.30			3.40				1/2	1.80	4.00	8.00	1/2	1.80	4.06	8.06	40	40		
MMP21			21.15	2.00	5.30	2.35	5.90	3.00	4.60	5.90	4.00	3/4	2.00	4.70	8.70	3/4	2.00	4.76	8.76	44	46		
MMP22			21.65	2.40	5.40			4.10					1/2	3/4	1.80	4.00	8.00	1/2	3/4	1.80	4.06	8.06	44

*DOES NOT CHANGE THE PRESSURE RATING OF THE PUMP

COPYRIGHT 2010 MAGNATEX PUMPS, INC.

Magnetic Drive sub-ANSI Pumps

MAGNATEX[®] MP Series

Close-coupled, compact, MP Series pumps are the efficient and dependable choice for medium-flow, medium-head applications. The MP Series pump features sub-ANSI sizes for efficient lower flow applications. Affordable, high-performance Magnatex[®] pumps give you higher efficiency with lower horsepower and a lower total cost of ownership.



- Standard SiC-X bearing system for enhanced dry running capability
- Straddle-mounted, double bearing design reduces shaft load and bearing wear when compared to our competitors' typical cantilevered, overhung designs
- Slip-fit construction allows easy maintenance and on-site repairs with no special tools required
- Large internal flow path handles solids: 1% at 500µ; 5% at 100µ.
- Close-coupled configuration eliminates coupling and motor alignment issues
- No expensive mechanical seals; eliminates costly shutdowns and pump repair, which helps eliminate "Reportable Release" issues
- Handles toxic, noxious and corrosive liquids for leak-free pumping with increased safety to plant personnel and the environment
- Optional high-temperature construction to handle up to 660°F
- Optional baffled rear casing design for enhanced solids handling

MAGNATEX[®] MP Series Specifications

Maximum Flow	150 GPM
Maximum Head	190 FT
Liquid Temperature	-112° F to +660° F
Maximum Power	10 HP
Maximum Working Pressure	150 psig
Connections	150# RF Flanges
Bearings	SiC/SiC-X Standard
Impeller	Enclosed
Speeds	Up to 3550 rpm
Magnets	Neodymium or Samarium Cobalt
Motor	NEMA or IEC Frame Mounted

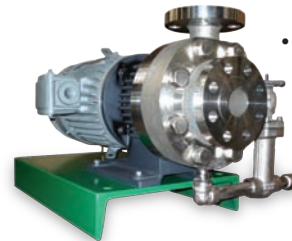

- **Optional, high-pressure models for suction conditions to 5000 psi and more**

Materials of Construction:

- 316SS
- Alloy 20
- Alloy B&C

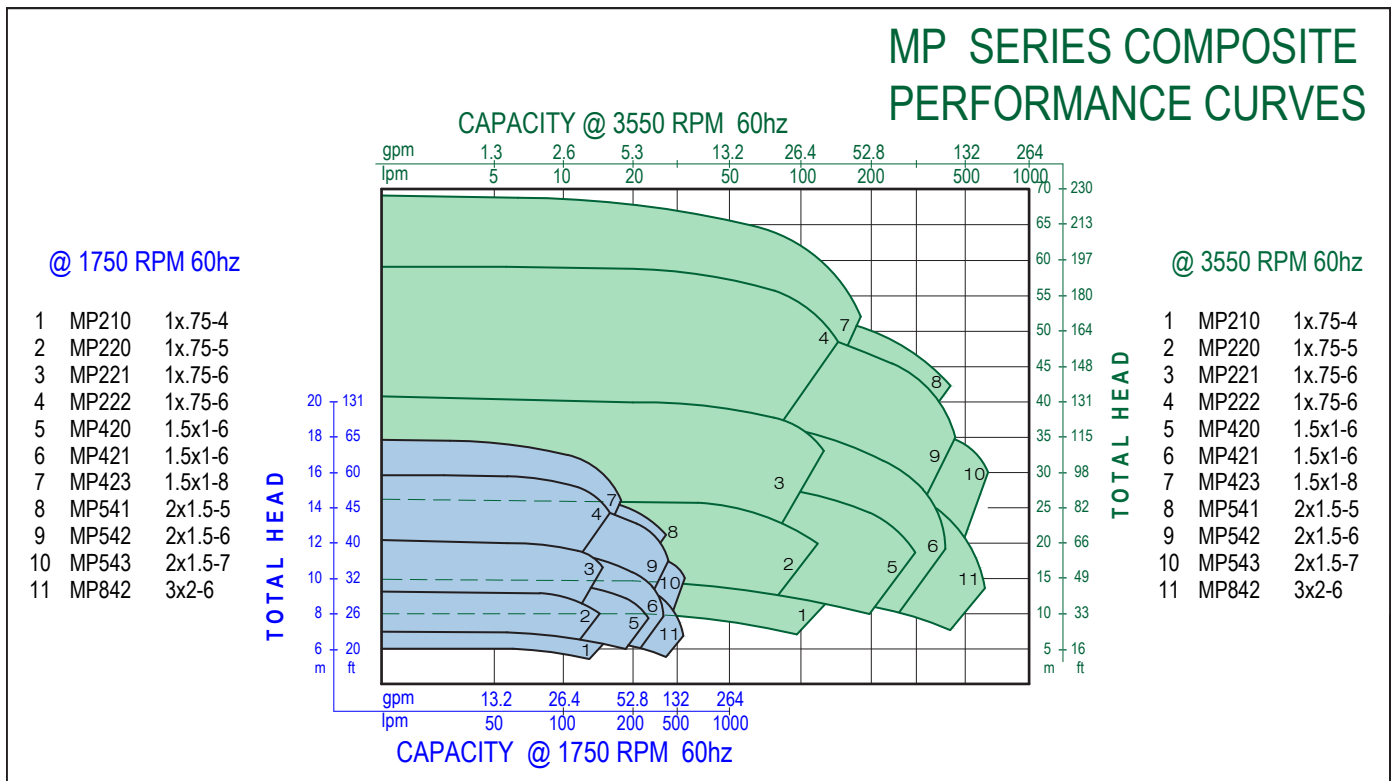

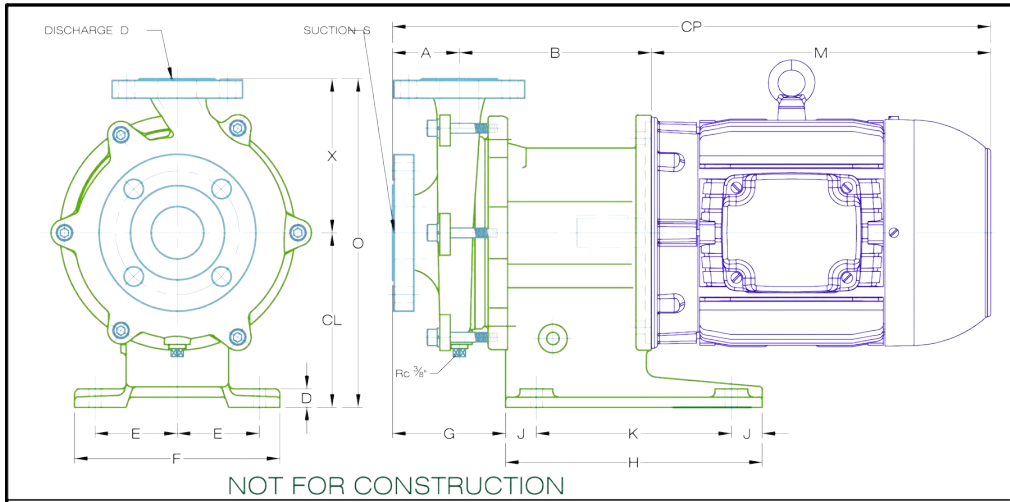
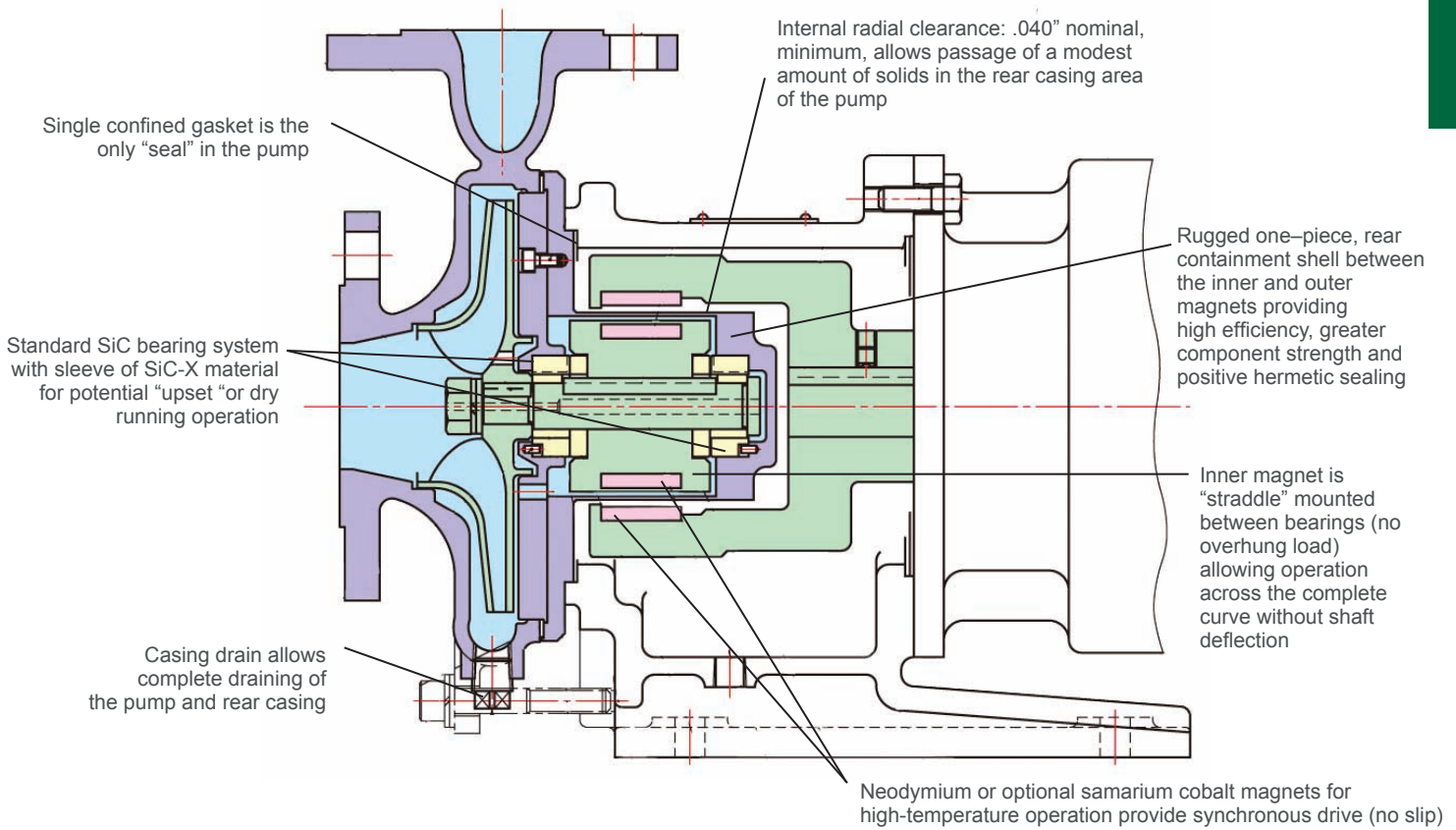

CONDUIT BOX SHOWN FOR ILLUSTRATION ONLY
REQUIRED LOCATION MUST BE SPECIFIED

MAGNATEX
Pumps, Inc.

DIMENSIONAL DRAWING
MP SERIES CLOSE-COUPLED PUMP

DRAWN BY: B VALENTIN DATE: 07/02/10 SCALE: NTS PAGE: 1 OF 1

DD-MP SERIES

ALL DIMENSIONS IN INCHES ± 0.12"

MODEL	DIMENSIONS														PUMP LBS	MOTOR FRAME	M	CP	MTR LBS	MOTOR FRAME	M	CP	MTR LBS
	S	D	A	B	D	E	F	G	H	J	K	X	CL	O									
MP220	1.00	0.75	2.36	6.85	0.47	2.56	5.12	4.33	7.09	1.18	4.72	4.72	4.33	9.06	55	56C	10.29	19.50	31	145TC	11.21	20.42	56
															55	143TC	10.23	19.44	54	184TC	12.96	22.17	108
															55	182TC	12.02	21.23	99	184TC	12.96	22.17	108
MP221	1.00	0.75	2.56	6.65	0.47	3.15	7.87	4.33	9.84	1.18	7.48	5.12	6.69	11.81	60	143TC	10.23	19.44	54	145TC	11.21	20.42	56
				60											182TC	12.02	21.94	99	184TC	12.96	22.88	108	
				60											143TC	10.23	19.44	54	145TC	11.21	20.42	56	
MP222	1.00	0.75	2.56	6.65	0.71	3.15	7.87	4.33	9.84	1.18	7.48	5.51	6.69	12.20	68	182TC	12.02	21.94	99	184TC	12.96	22.88	108
				60											143TC	10.23	19.44	54	145TC	11.21	20.42	56	
				60											182TC	12.02	21.94	99	184TC	12.96	22.88	108	
MP420 / 421	1.50	1.00	2.95	6.85	0.71	3.15	7.87	4.92	9.84	1.18	7.48	5.31	6.69	12.01	62	143TC	10.23	20.03	54	145TC	11.21	21.01	56
				62											182TC	12.02	22.53	99	184TC	12.96	23.47	108	
				62											143TC	10.23	20.23	54	145TC	11.21	21.21	56	
MP423	1.50	1.00	4.02	9.41	0.71	4.92	11.42	4.92	13.78	0.98	11.81	6.50	7.09	13.58	139	213TC	14.59	28.02	139	215TC	16.09	29.52	173
				139											143TC	10.23	20.23	54	145TC	11.21	21.21	56	
				139											182TC	12.02	22.73	99	184TC	12.96	23.67	108	
MP541	2.00	1.50	3.15	6.85	0.71	3.15	7.87	5.12	9.84	1.18	7.48	5.51	6.69	12.20	73	182TC	12.02	21.94	99	184TC	12.96	22.88	108
				73											143TC	10.23	19.44	54	145TC	11.21	20.42	56	
				73											182TC	12.02	21.94	99	184TC	12.96	22.88	108	
MP542	2.00	1.50	2.56	7.36	0.71	3.15	7.87	4.33	9.84	1.18	7.48	5.91	6.69	12.60	79	182TC	12.02	21.94	99	184TC	12.96	22.88	108
				79											143TC	10.23	19.44	54	145TC	11.21	20.42	56	
				79											182TC	12.02	21.94	99	184TC	12.96	22.88	108	
MP543	2.00	1.50	4.02	9.41	0.71	4.92	11.42	4.92	13.78	0.98	11.81	6.50	7.09	13.58	143	213TC	14.59	28.02	139	215TC	16.09	29.52	173
				143											143TC	10.23	19.44	54	145TC	11.21	20.42	56	
				143											182TC	12.02	21.94	99	184TC	12.96	22.88	108	
MP842	3.00	1.50	4.20	9.41	0.71	4.92	11.42	0.98	13.78	0.98	11.81	6.50	7.09	13.58	147	213TC	14.59	28.20	139	215TC	16.09	29.70	173
				147											143TC	10.23	19.44	54	145TC	11.21	20.42	56	
				147											182TC	12.02	21.94	99	184TC	12.96	22.88	108	

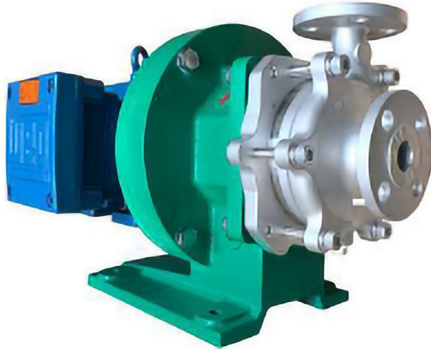

Magnetic Drive sub-ANSI Pumps

MAGNATEX[®] ML Series

Close-coupled, compact, ML Series pumps are the efficient and dependable choice for medium-flow, medium-head, colder applications. The ML Series pump features sub-ANSI sizes for efficient, lower flow applications. Affordable, high performance Magnatex[®] pumps give you higher efficiency with lower horsepower and a lower total cost of ownership.

- Standard SiC-X bearing system for enhanced dry running capability.
- Straddle-mounted, double bearing design reduces shaft load and bearing wear when compared to competitor's typical cantilevered, overhung designs.
- Slip-fit construction allows easy maintenance and on-site repairs with no special tools required.
- Use of an inert gas or dry air purge port to prevent icing that may develop in the rear casing area is optional. This may occur on colder-temperature applications in a non-controlled humidity environment.
- Close-coupled configuration eliminates coupling and motor alignment issues.
- No expensive mechanical seals; eliminates costly shutdowns and pump repair, which helps eliminate "Reportable Release" issues.
- Handles toxic, noxious and corrosive liquids for leak-free pumping with increased safety to plant personnel and the environment

MAGNATEX[®] ML Series Specifications

Maximum Flow	100 GPM
Maximum Head	190 FT
Liquid Temperature	-112°F to +300°F
Maximum Power	5 HP
Connections	150lb RF Flanges
Bearing	SiC/SiC-X Standard
Max Working Pressure	150 psig
Impeller	Enclosed
Speeds	Up to 3550 rpm
Magnets	Neodymium
Motor	NEMA or IEC Frame Mounted

Materials of Construction:

- 316SS
- Alloy 20
- Alloy B&C

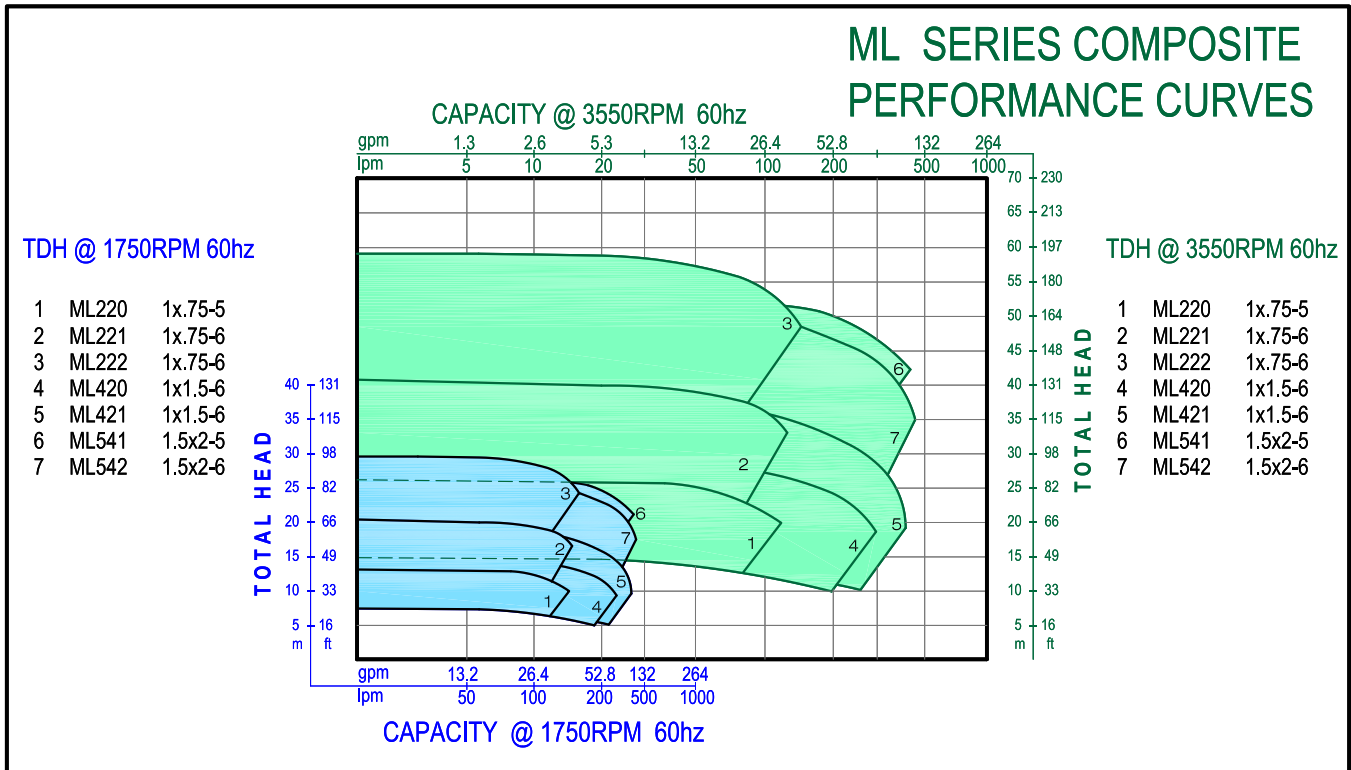

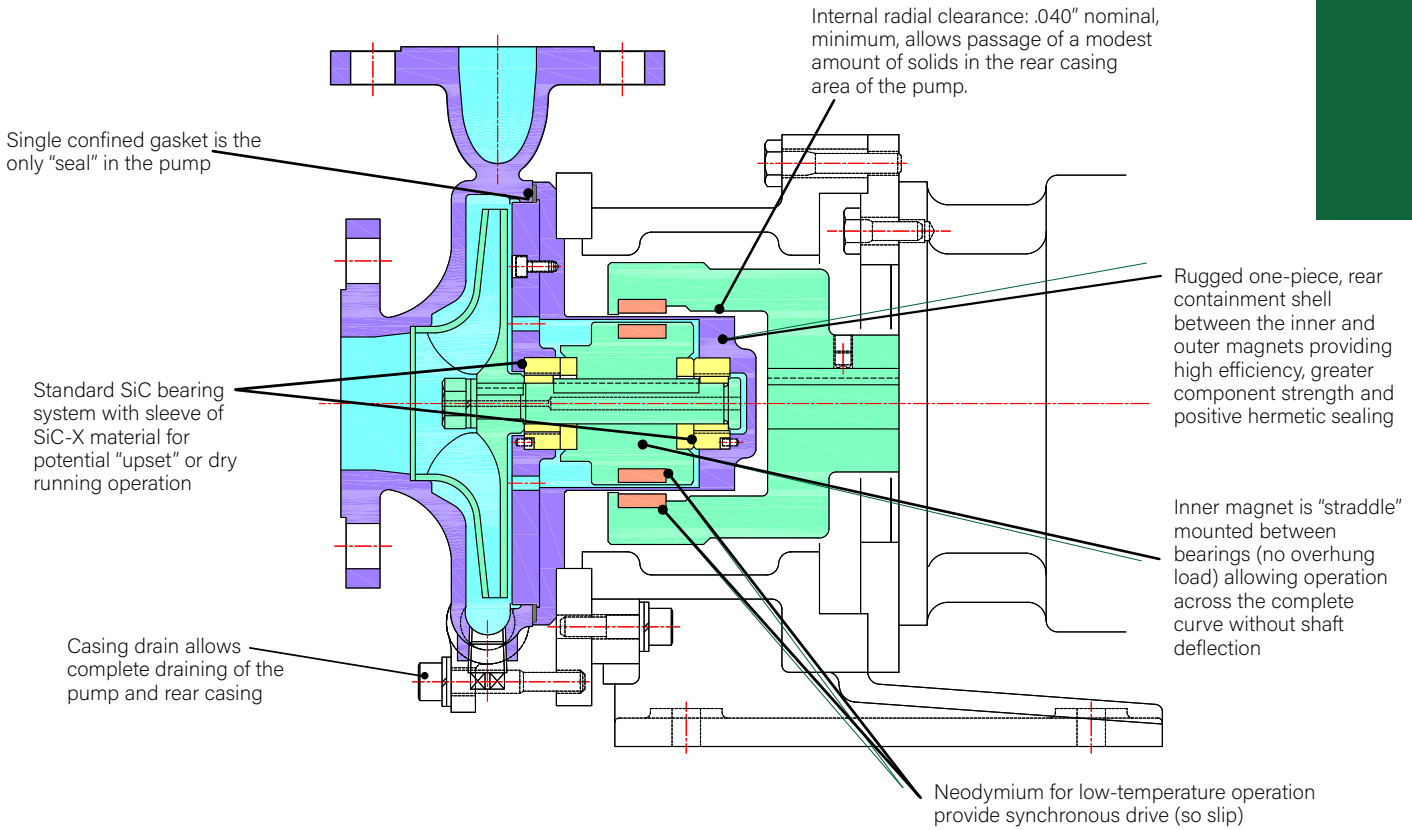

DISCHARGE D

SUCTION S

X

O

CL

D₁

E

F

CP

A

B

M*

Rc 3/8"

5.91

2-3/8" NPT, N2 PURGE PORT (0.5-1.0L/min)

J

K

J

G

H

STANDARD F1 CONDUIT BOX SHOWN FOR ILLUSTRATION ONLY. OTHER LOCATION MUST BE SPECIFIED.

NOT FOR CONSTRUCTION

MAGNATEX
Pumps, Inc.

DIMENSIONAL DRAWING
ML SERIES CLOSE-COUPLED PUMP

DRAWN BY: **K HUFFER** DATE: **8/13/19** SCALE: **NTS** PAGE: **1 OF 1**

DD-ML SERIES

ALL DIMENSIONS IN INCHES ± 0.12"

* VARIES BY MANUFACTURER

MODEL	DIMENSIONS														PUMP LBS	MOTOR FRAME	M*	CP*	MOTOR LBS*
	S	D	A	B	D	E	F	G	H	J	K	X	CL	O					
ML220	1.00	0.75	2.36	6.85	0.71	3.15	7.87	4.33	9.84	1.18	7.48	4.72	6.69	11.42	55	56C	10.29	19.50	31
				143/5TC												11.11	20.32	51	
ML221	1.00	0.75	2.56	6.65	0.71	3.15	7.87	4.33	9.84	1.18	7.48	5.12	6.69	11.81	55	143/5TC	11.11	20.32	51
				7.36												182/4TC	13.11	23.03	93
ML222	1.00	0.75	2.56	6.85	0.71	3.15	7.87	4.33	9.84	1.18	7.48	5.51	6.69	12.20	59	143/5TC	11.11	20.52	51
				7.36												182/4TC	13.11	23.03	93
ML420	1.50	1.00	2.95	6.69	0.71	3.15	7.87	4.92	9.84	1.18	7.48	5.31	6.69	12.01	64	56C	10.29	19.93	31
				143/5TC												11.11	20.75	51	
ML421	1.50	1.00	2.95	6.85	0.71	3.15	7.87	4.92	9.84	1.18	7.48	5.31	6.69	12.01	62	143/5TC	11.11	20.91	51
				7.56												182/4TC	13.11	23.62	93
ML541	2.00	1.50	3.15	7.56	0.71	3.15	7.87	5.12	9.84	1.18	7.48	5.51	6.69	12.20	64	182TC	13.11	23.82	93
				73												184TC			
ML542	2.00	1.50	2.56	7.36	0.71	3.15	7.87	4.33	9.84	1.18	7.48	5.91	6.69	12.60	70	182TC	13.11	23.03	93
				79												184TC			

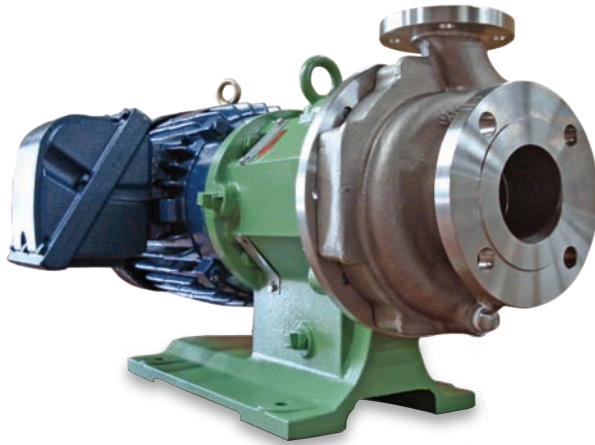

MAGNATEX[®] MPL Series Specifications

Maximum Flow	340 GPM
Maximum Head	400 FT
Liquid Temperature	-100° F to +660° F
Maximum Power	20 HP
Maximum Working Pressure	170 or 225 psig
Connections	150# RF Flanges
Bearings	SiC/SiC-X Optional
Impeller	Enclosed
Speeds	Up to 3550 rpm
Magnets	Samarium Cobalt or Neodymium
Motor	NEMA or IEC Frame Mounted

Magnetic Drive Pumps

MAGNATEX[®] MPL Series

Close coupled, compact, MPL Series pumps are the efficient and dependable choice for medium to high head applications. The process side of the MPL pump conforms to ANSI B73.3 dimensions. Affordable, high performance Magnatex[®] pumps give you higher efficiency with lower first cost, lower horsepower and a lower total cost of ownership.

- Optional SiC-X bearing system for enhanced dry running capability
- Straddle-mounted, double bearing design reduces shaft load and bearing wear when compared to our competitors' typical cantilevered, overhung designs
- Slip-fit construction allows easy maintenance and on-site repairs with no special tools required
- Close-coupled configuration eliminates coupling and motor alignment issues
- No expensive mechanical seals; eliminates costly shutdowns and pump repair, which helps eliminate "Reportable Release" issues
- Handles toxic, noxious and corrosive liquids for leak-free pumping with increased safety to plant personnel and the environment
- Optional high temperature construction to handle up to 660°F
- Optional baffled rear casing design for enhanced solids handling
- Large internal flow path handles solids: 1% at 500μ; 5% at 100μ

Materials of Construction:

- 316SS
- Alloy 20
- 304SS
- Alloy B&C

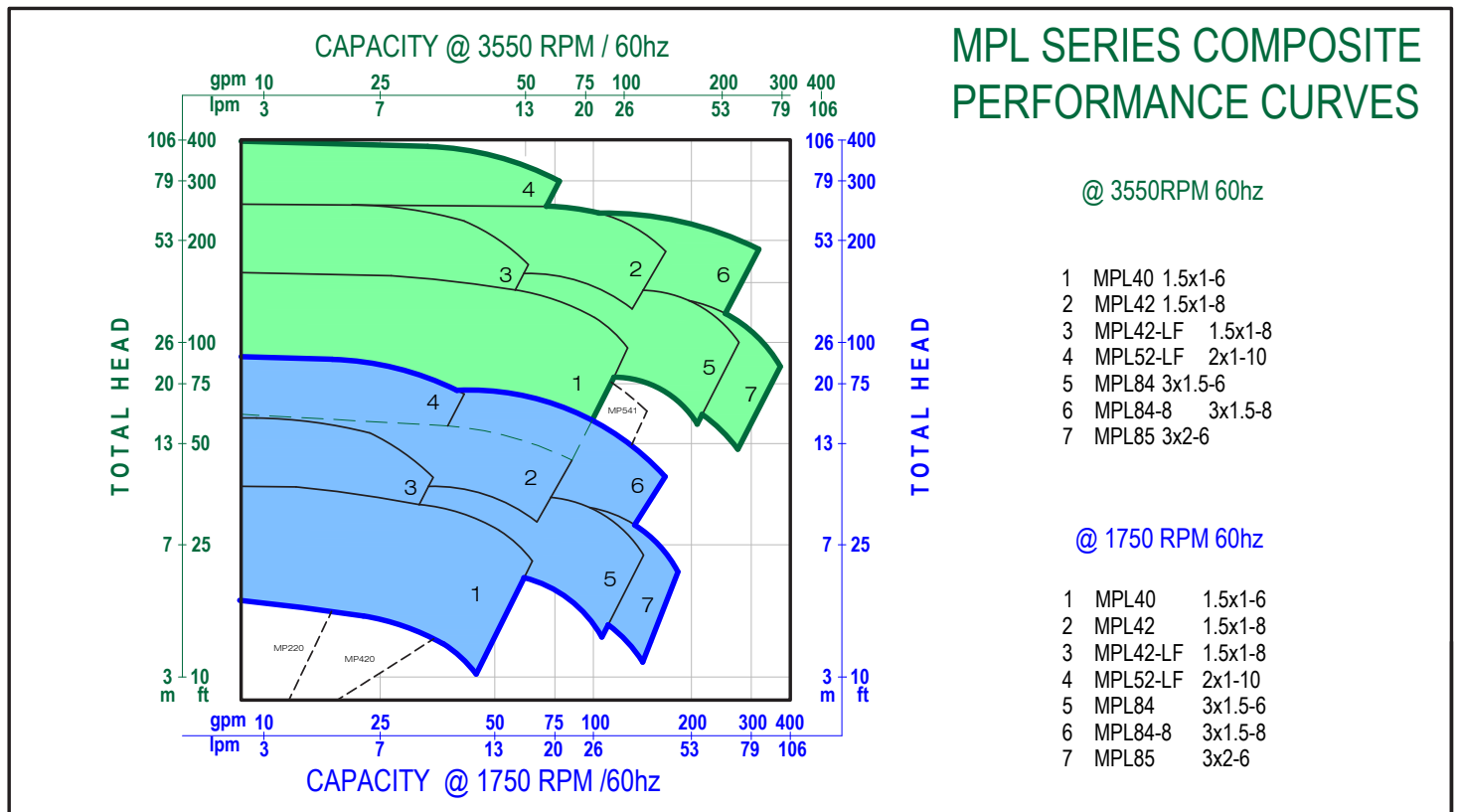

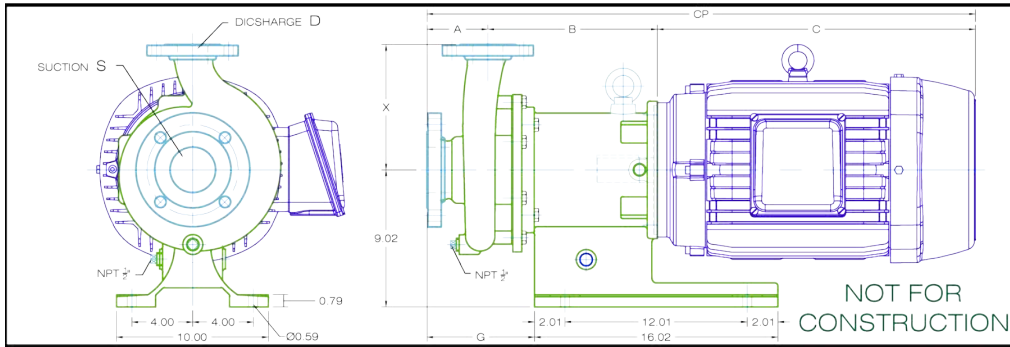
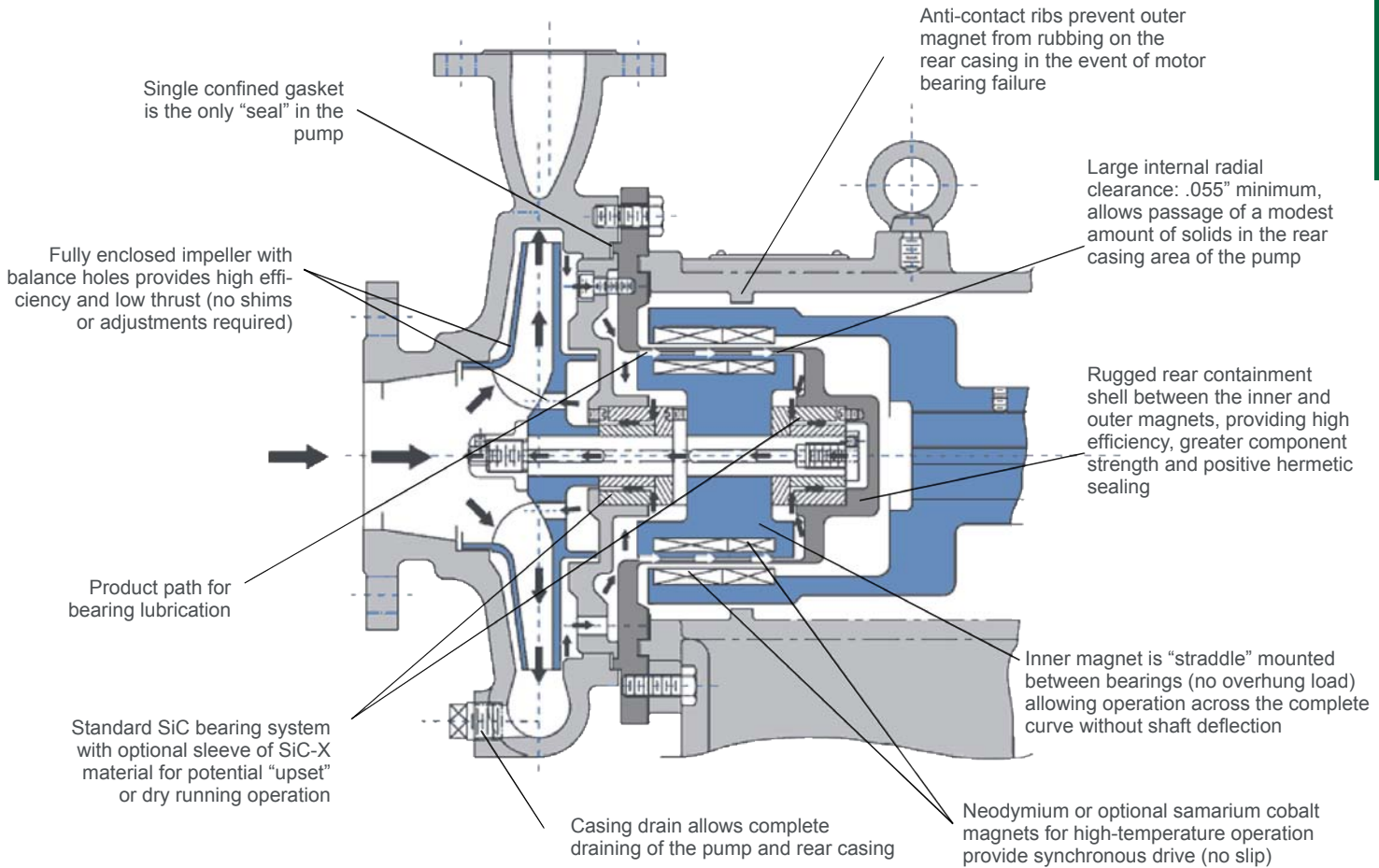

CONDUIT BOX SHOWN FOR ILLUSTRATION ONLY
REQUIRED LOCATION MUST BE SPECIFIED

MAGNATEX[®]
Pumps, Inc.

DIMENSIONAL DRAWING
MPL SERIES ANSI PUMP

DRAWN BY: B. VALENTIN DATE: 06/29/10 SCALE: NTS PAGE: 1 OF 1

DD-MPL SERIES

ALL DIMENSIONS IN INCHES ± 0.12"

MODEL	DIMENSIONS																
	S	D	A	B	X	G	PUMP LBS	MOTOR FRAME	C	CP	MTR LBS	Total lbs	MOTOR FRAME	C	CP	MTR LBS	Total lbs
MPL40	1.5	1.0	4.0	11.0	6.5	6.9	187	182TC	12.02	22.98	99	286	184TC	13.01	27.99	108	295
								213TC	14.59	25.55	165	352	215TC	16.09	31.07	153	340
								254TC	19.21	30.17	238	425	256TC	20.96	35.94	259	446
MPL42	1.5	1.0	4.0	11.0	6.5	6.9	187	182TC	12.02	22.98	99	286	184TC	13.01	27.99	108	295
								213TC	14.59	25.55	165	352	215TC	16.09	31.07	153	340
								254TC	19.21	30.17	238	425	256TC	20.96	35.94	259	446
MPL42LF	1.5	1.0	4.0	11.0	6.5	6.9	187	182TC	12.02	22.98	99	286	184TC	13.01	27.99	108	295
								213TC	14.59	25.55	165	352	215TC	16.09	31.07	153	340
								254TC	19.21	30.17	238	425	256TC	20.96	35.94	259	446
MPL52LF	2.0	1.0	4.0	11.2	8.5	7.1	187	182TC	12.02	23.18	99	286	184TC	13.01	28.19	108	295
								213TC	14.59	25.75	165	352	215TC	16.09	31.27	153	340
								254TC	19.21	30.37	238	425	256TC	20.96	36.14	259	446
MPL84	3.0	1.5	4.0	11.0	6.5	6.9	187	182TC	12.02	22.98	99	286	184TC	13.01	27.99	108	295
								213TC	14.59	25.55	165	352	215TC	16.09	31.07	153	340
								254TC	19.21	30.17	238	425	256TC	20.96	35.94	259	446
MPL84-8	3.0	1.5	4.0	11.2	8.5	7.1	187	182TC	12.02	23.18	99	286	184TC	13.01	28.19	108	295
								213TC	14.59	25.75	165	352	215TC	16.09	31.27	153	340
								254TC	19.21	30.37	238	425	256TC	20.96	36.14	259	446
MPL85	3.0	2.0	4.0	11.2	8.3	7.1	187	182TC	12.02	23.18	99	286	184TC	13.01	28.19	108	295
								213TC	14.59	25.75	165	352	215TC	16.09	31.27	153	340
								254TC	19.21	30.37	238	425	256TC	20.96	36.14	259	446

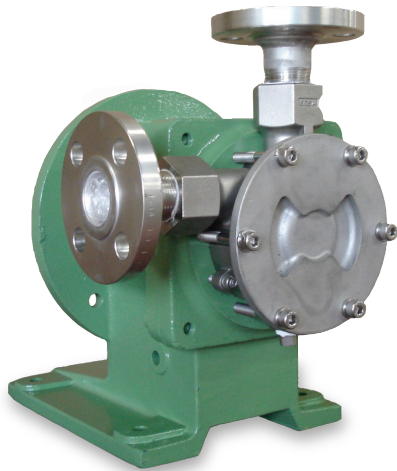

MAGNATEX® MPT Series Specifications

Maximum Flow	40 GPM
Maximum Head	440 FT
Liquid Temperature	-20° F to +446° F
Maximum Power	5 HP
Maximum Working Pressure	232 psig
Connections	NPT with Optional Flanges
Bearings	SiC/SiC-X
Impeller	Turbine Vane
Speeds	Up to 3550 rpm
Magnets	Samarium Cobalt + Neodymium
Motor	NEMA or IEC Frame Mounted

Magnetic Drive Regenerative Turbine Pumps

MAGNATEX® MPT Series

MPT Series magnetically driven, sealless, regenerative turbine vane pumps are designed specifically for small flows at high heads. The MPT Series features close-coupled construction similar to the MP Series, but uses a regenerative turbine vane impeller. This design provides better pump hydraulics at low flow rates and low NPSHa conditions.

- Standard SiC-X bearing system for enhanced dry running capability
- Straddle-mounted, inner magnet system, with bearings on both sides of the magnet, which reduces shaft and bearing loads when compared to our competitors' overhung, cantilevered inner magnet designs
- Slip-fit construction that allows easy on-site maintenance, with no special tools or fixtures required
- Close-coupled configuration eliminates coupling and motor alignment issues
- No expensive mechanical seals; eliminates costly shutdowns and pump repair, which helps eliminate "Reportable Release" issues
- Handles toxic, noxious and corrosive liquids for leak-free pumping with increased safety to plant personnel and the environment.
- Excellent for pumping entrained gases
- Excellent for low NPSHa applications

Materials of Construction:

- 316SS
- Alloy B & C
- Alloy 20
- Titanium

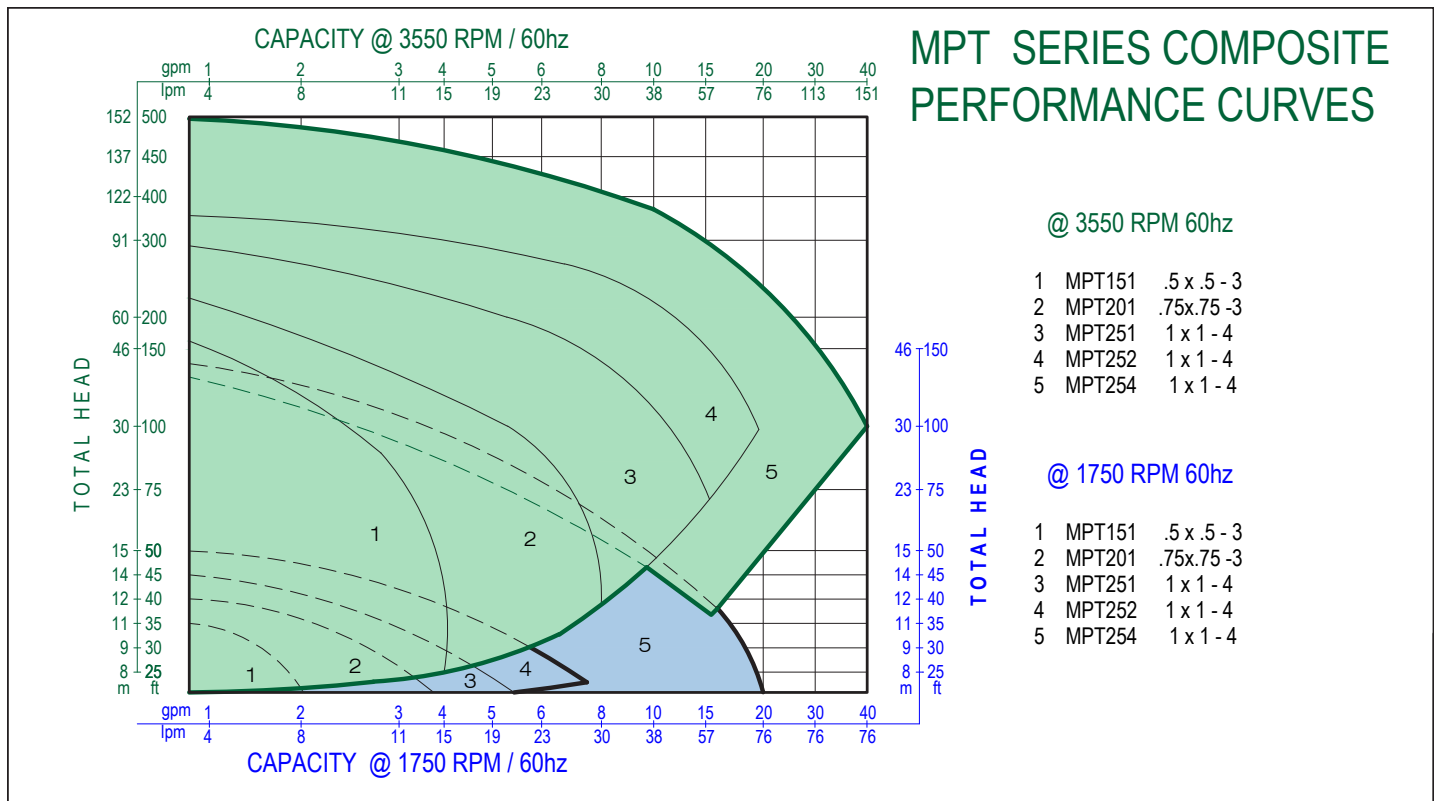

MAGNATEX®

HOW A REGENERATIVE TURBINE PUMP WORKS

- The unusual regenerative turbine impeller design involves a large number of blades machined into the periphery of the impeller.
- Blades are on both sides of the centerline to limit axial thrust, which hydraulically centers the impeller during operation.
- Instead of the liquid entering the impeller at the shaft centerline and exiting at the impeller periphery, liquid enters a regenerative turbine pump in the vicinity of the impeller OD. After acceleration around the pump casing it discharges through a port in the same plane as the suction.
- There is considerable debate about the fluid dynamics involved in regenerative turbine pumps, but the consensus of expert opinion is that liquid entering the impeller blade is accelerated radially and tangentially in the direction of rotation. Liquid moving outward toward the casing is reflected back onto the next impeller blade where it is further accelerated. This process is repeated many times until the liquid exits the discharge port.
- The clearances between the impeller and casing and between the inlet and outlet are smaller to minimize backflow in the discharge segment of the casing.
- Regenerative turbine pumps develop much more head for the impeller diameter and speed of rotation when compared to a typical centrifugal pump.
- Because of the special impeller design, regenerative turbine pumps are excellent for low NPSH applications.

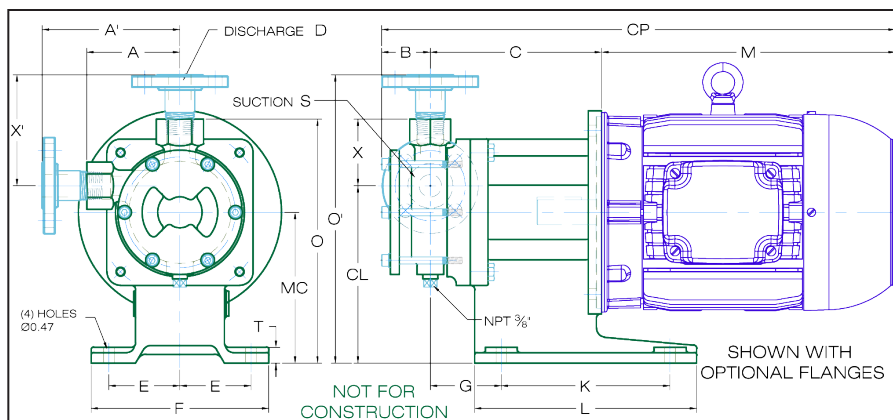
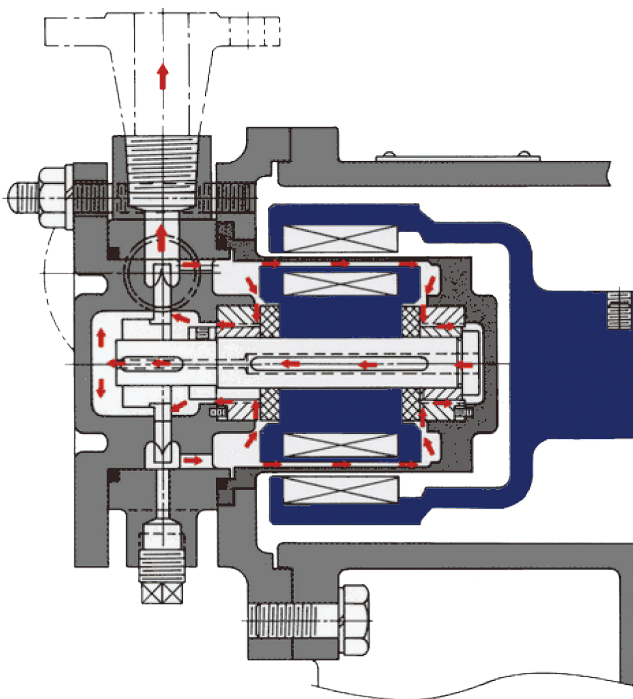

CONDUIT BOX SHOWN FOR ILLUSTRATION ONLY
REQUIRED LOCATION MUST BE SPECIFIED



DIMENSIONAL DRAWING MPT SERIES CLOSE-COUPLED PUMP

DRAWN BY: B VALENTIN DATE: 10/20/10 SCALE: NTS PAGE: 1 OF 1

DD-MPT-SERIES R1

ALL DIMENSIONS ± 0.12" [3mm]

MODEL	MOTOR FRAME		DIMENSIONS in INCHES [MILLIMETERS]													STANDARD NPT				*OPTIONAL 150# ANSI RF				APROX. WEIGHT	
	NEMA	IEC	M	CP	MC	CL	B	C	E	F	G	K	L	T	S & D	A	X	O	S & D	A'	X'	O'	PUMP lbs.(kgs.)	MOTOR lbs.(kgs.)	
MPT 151	56C	63,71,80	10.29 [261]	18.30 [465]	4.33 [110]	5.31 [135]	1.36 [34.5]	6.65 [169]	2.56 [65]	6.30 [160]	2.99 [76]	4.72 [120]	7.09 [180]	0.47 [12]	1/2" [13]	3.15 [80]	2.17 [55]	7.48 [190]	1/2" [13]	5.12 [130]	4.13 [105]	9.45 [240]	35 (16)	31 (14)	
	143TC	90S	10.23 [260]	18.50 [470]	4.33 [110]	5.31 [135]	1.42 [42]	6.85 [174]	2.56 [65]	6.30 [160]	3.15 [80]	4.72 [120]	7.09 [180]	0.47 [12]	3/4" [20]	3.15 [80]	2.17 [55]	7.48 [190]	3/4" [20]	5.12 [130]	4.13 [105]	9.45 [240]	44 (20)	31 (31) 54 (25) 58 (26)	
MPT 201	145TC	90L	11.50 [292]	19.77 [502]	4.33 [110]	5.51 [140]	1.61 [41]	6.85 [174]	2.56 [65]	6.30 [160]	3.15 [80]	4.72 [120]	7.09 [180]	0.47 [12]	1" [25]	4.13 [105]	2.95 [75]	8.46 [215]	1" [25]	6.10 [155]	4.92 [125]	10.43 [265]	44 (20)	54 (25) 58 (26)	
	182TC	112S	12.02 [305]	21.23 [539]	6.69 [170]	7.87 [200]	1.77 [45]	7.60 [193]	3.15 [80]	7.87 [200]	3.15 [80]	7.48 [190]	9.87 [251]	0.71 [18]	1" [25]	4.13 [105]	2.95 [75]	10.83 [275]	1" [25]	6.10 [155]	4.92 [125]	12.80 [325]	55 (25)	99 (45) 108 (49)	
	184TC	112L	13.01 [330]	22.22 [564]	6.69 [170]	7.87 [200]	1.77 [45]	7.60 [193]	3.15 [80]	7.87 [200]	3.15 [80]	7.48 [190]	9.87 [251]	0.71 [18]	1" [25]	4.13 [105]	2.95 [75]	10.83 [275]	1" [25]	6.10 [155]	4.92 [125]	12.80 [325]	55 (25)	99 (45) 108 (49)	
	143TC	90S	10.23 [260]	18.85 [479]	4.33 [110]	5.51 [140]	1.77 [45]	6.85 [174]	2.56 [65]	6.30 [160]	3.15 [80]	4.72 [120]	7.09 [180]	0.47 [12]	1" [25]	4.13 [105]	2.95 [75]	8.46 [215]	1" [25]	6.10 [155]	4.92 [125]	10.43 [265]	44 (20)	54 (25) 58 (26)	
MPT252	145TC	90L	11.50 [292]	20.12 [511]	4.33 [110]	5.51 [140]	1.77 [45]	6.85 [174]	2.56 [65]	6.30 [160]	3.15 [80]	4.72 [120]	7.09 [180]	0.47 [12]	1" [25]	4.13 [105]	2.95 [75]	8.46 [215]	1" [25]	6.10 [155]	4.92 [125]	10.43 [265]	44 (20)	54 (25) 58 (26)	
	182TC	112S	12.02 [305]	21.39 [543]	6.69 [170]	7.87 [200]	1.77 [45]	7.60 [193]	3.15 [80]	7.87 [200]	3.15 [80]	7.48 [190]	9.87 [251]	0.71 [18]	1" [25]	4.13 [105]	2.95 [75]	10.83 [275]	1" [25]	6.10 [155]	4.92 [125]	12.80 [325]	55 (25)	99 (45) 108 (49)	
	184TC	112L	13.01 [330]	22.38 [568]	6.69 [170]	7.87 [200]	1.77 [45]	7.60 [193]	3.15 [80]	7.87 [200]	3.15 [80]	7.48 [190]	9.87 [251]	0.71 [18]	1" [25]	4.13 [105]	2.95 [75]	10.83 [275]	1" [25]	6.10 [155]	4.92 [125]	12.80 [325]	55 (25)	99 (45) 108 (49)	

*DOES NOT CHANGE THE PRESSURE RATING OF THE PUMP

COPYRIGHT 2010 MAGNATEX PUMPS INC.



3575 West 12th Street Houston, TX 77008
tel: 713.972.8666 toll free: 866.MAGPUMP fax: 713.972.8665
www.magnatexpumps.com



MAGNATEX® MAXP Series Specifications

Maximum Flow	2000 GPM
Maximum Head	470 FT
Liquid Temperature	-150°F – 800°F
Maximum Power	up to 200 HP
Connections	150lb RF std. or optional 300lb RF ANSI Flanges
Bearing	SiC, SiC-X optional for upset or Dry-run Conditions
Maximum Working Pressure (standard)	285 psig
Impeller	Enclosed
Speeds	up to 3550 rpm
Magnets	Neodymium or Samarium Cobalt for High Temperature
Motor	NEMA or IEC Frame
Secondary Containment	Optional
Steam Jackets	Optional
External Flush	Optional
Re-circulated Flush & Vent	Optional
Vortex Breakers	Optional for Improved Solids Handling
Centerline mounted	Optional

Magnetic Drive Sealless ANSI Process Pumps

MAGNATEX® MAXP Series

The MAXP Series of pumps has been designed to conform to ANSI B73.3 dimensional standards. The pumps are extremely rugged, which makes them ideal for rigorous duty in the chemical and petrochemical industries.

Magnatex MAXP pumps have the following design features:

- Straddle-mounted inner magnet system with bearings on both sides of the magnet—this design reduces shaft and bearing loads when compared to our competitors' overhung, cantilevered, inner magnet designs
- Slip-fit construction, which allows easy on-site maintenance with no special tools or fixtures required
- Large internal flow paths, which means the pumps can easily handle 1% solids @ 500µ and up to 5% solids @ 100µ. Optional baffle-plated rear casing enables enhanced solids handling capability. Optional proprietary self-cleaning strainer technology enables us to handle even higher solids percentages if necessary
- No expensive mechanical seals; eliminates costly shutdowns and repairs, which helps eliminate "Reportable Release" issues
- Safely handles toxic, noxious, corrosive or high-temperature liquids with increased safety to personnel and the environment
- Special high-temperature construction is available to handle up to 800°F
- Several dual containment systems are available that virtually eliminate any leakage to the environment when handling extremely hazardous chemicals

Materials of Construction:

- 316SS
- Alloy 20
- Monel
- 304SS
- Alloy B & C
- Titanium

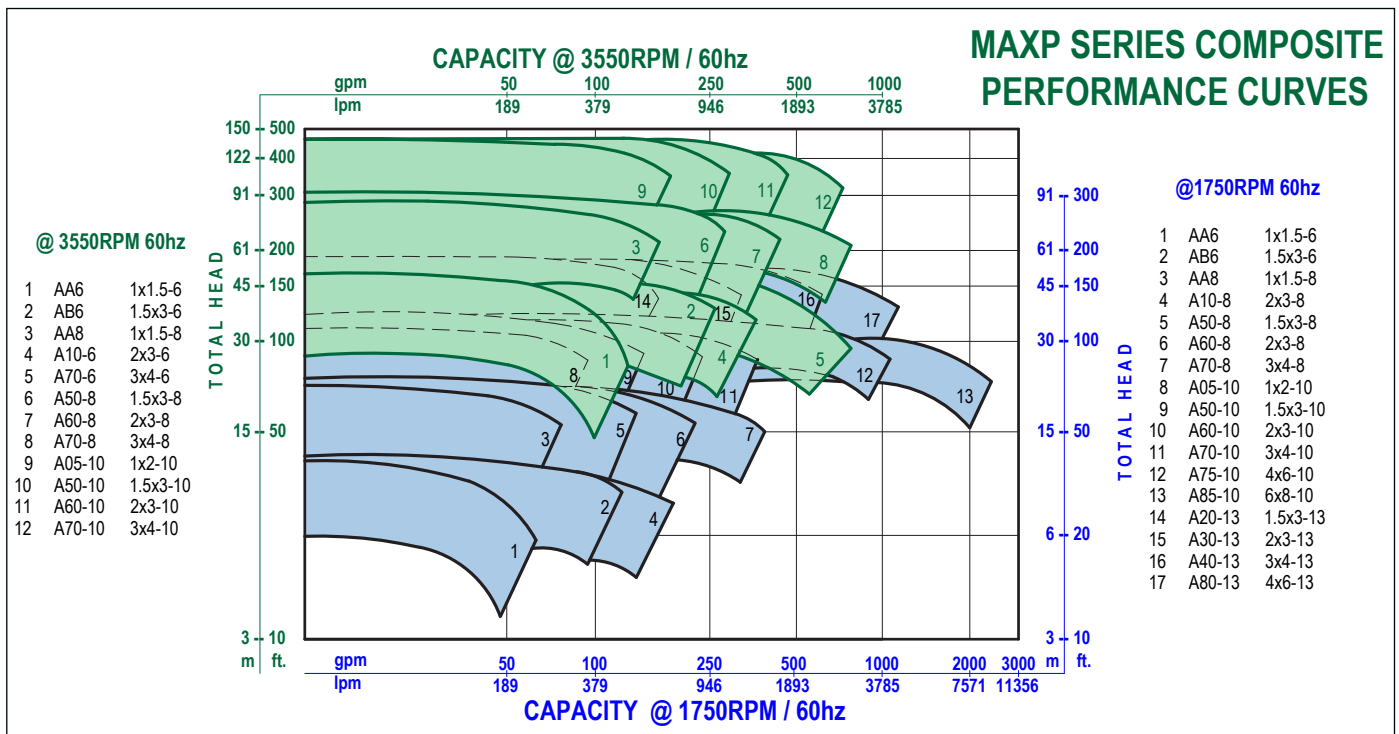

ANATOMY OF THE ULTIMATE MAGNETIC DRIVE PUMP

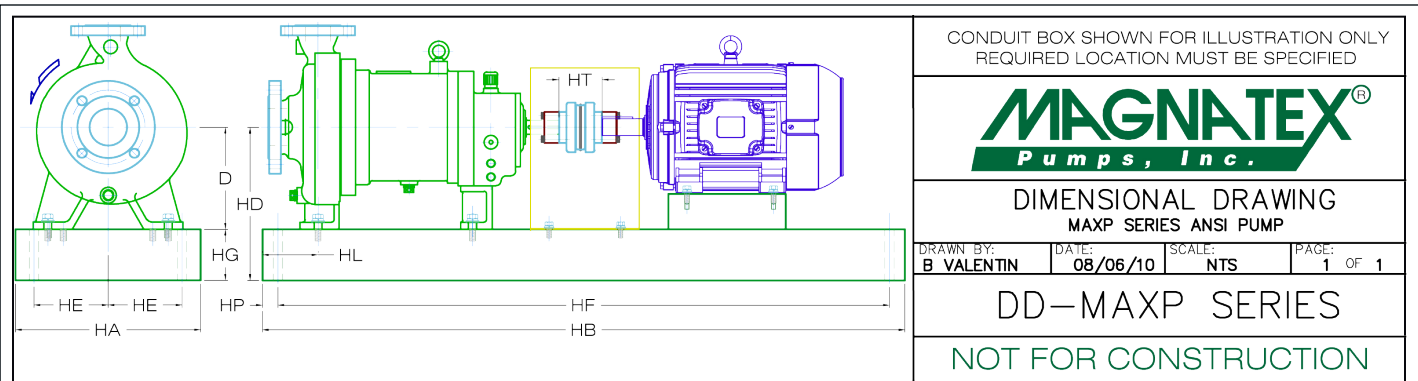
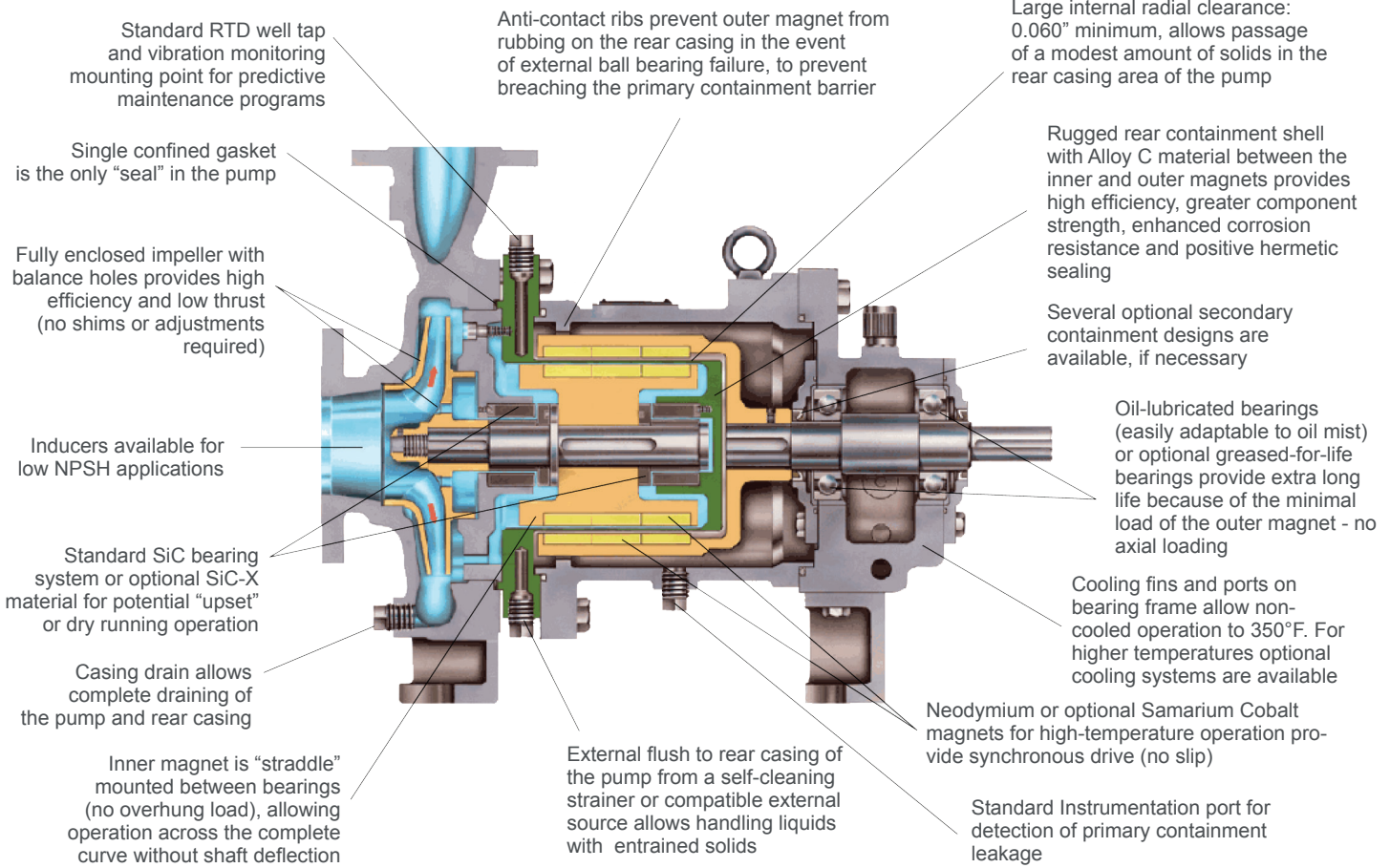

MAGNATEX MAXP SERIES ANSI BASEPLATE DIMENSIONS

NEMA Frame	Baseplate No.	HA MAX.	HB	HT	HD MAX.				HE	HF	HG MAX.	HH	HL	HP
					D=5.25 [133]	D=8.25 [210]	D=10 [254]	D=14.5 [368]						
184T	139	15 [381]	39 [991]	3.5 [89]	9 [229]	4.5 [114]	36.5 [927]	3.75 [95]	0.75 [19]	4.5 [114]	1.25 [32]
256T	148	18 [457]	48 [1219]	3.5 [89]	10.5 [267]	6 [152]	45.5 [1156]	4.13 [105]	0.75 [19]	4.5 [114]	1.25 [32]
326TS	153	21 [533]	53 [1346]	3.5 [89]	12.88 [327]	7.5 [191]	50.5 [1283]	4.75 [121]	0.75 [19]	4.5 [114]	1.25 [32]
184T	245	15 [381]	45 [1143]	3.5 [89]	12 [305]	13.75 [349]	4.5 [114]	42.5 [1080]	3.75 [95]	0.75 [19]	4.5 [114]	1.25 [32]
215T	252	18 [457]	52 [1321]	3.5 [89]	12.38 [314]	14.13 [359]	6 [152]	49.5 [1257]	4.13 [105]	0.75 [19]	4.5 [114]	1.25 [32]
286T	258	21 [533]	58 [1473]	3.5 [89]	13 [330]	14.75 [375]	7.5 [191]	55.5 [1410]	4.75 [121]	1 [25]	4.5 [114]	1.25 [32]
365T	264	21 [533]	64 [1626]	3.5 [89]	13.88 [353]	14.75 [375]	7.5 [191]	61.5 [1562]	4.75 [121]	1 [25]	4.5 [114]	1.25 [32]
405TS	268	26 [660]	68 [1727]	3.5 [89]	14.88 [378]	14.88 [378]	9.5 [241]	65.5 [1664]	4.75 [121]	1 [25]	4.5 [114]	1.25 [32]
449TS	280	26 [660]	80 [2032]	3.5 [89]	15.88 [403]	15.88 [403]	9.5 [241]	77.5 [1969]	4.75 [121]	1 [25]	4.5 [114]	1.25 [32]
286T	368	26 [660]	68 [1727]	5 [127]	19.25 [489]	9.5 [241]	65.5 [1664]	4.75 [121]	1 [25]	4.5 [114]	1.25 [32]
405T	380	26 [660]	80 [2032]	5 [127]	19.25 [489]	9.5 [241]	77.5 [1096]	4.75 [121]	1 [25]	4.5 [114]	1.25 [32]
449T	398	26 [660]	98 [2489]	5 [127]	19.25 [489]	9.5 [241]	95.5 [2426]	4.75 [121]	1 [25]	4.5 [114]	1.25 [32]

In inches [millimeters]

COPYRIGHT 2010 MAGNATEX PUMPS, INC.



Mechanical Seal ANSI Pumps

MAGNATEX® 3596 Series

Heavy-duty, world-class quality process pumps built to the latest ANSI/ASME B73.1 standard.



Centerline-mounting available for +500°F services with pedestal cooling option; casing and/or seal chamber jacketing available, where required



Also available, MLS AA6, 1x1.5-6, PFA-lined model with proprietary, outside seal

- Competitively priced
- Available in 29 sizes
- Materials include WCB (steel - upgrade from ductile iron), 316SS, CD4MCu, CD4MCuN, Duplex & Super Duplex SS, (1B, 1C, 5A, 6A), Alloy B/C, Nickel, Monel, and Titanium; MLS AA6, 1x1.5-6, PFA-lined model with proprietary, outside seal is also available
- Bearing frames, bearing covers, and frame adaptors available in 316SS
- All stainless and alloy wet end components are investment cast, assuring excellent surface finish, as well as eliminating cracks and porosity
- Cast parts are manufactured using state-of-the-art CNC machines to ensure proper fit-up and repeatability
- High tolerance standards closely maintained
- Labyrinth seals are standard to protect the bearing housing from environmental contaminants
- Large metal/glass sight gauge ensures visibility of lubricant to help maintain the proper oil level
- Large bore seal chambers ideal for cartridge seals are standard; Tapered bore with straight vanes, as well as standard bore for component seals and packing are available. A dynamic seal option can also be provided
- Inventories are based on WCB (steel) and 316SS; other above materials available
- Shaft kits, Maintenance Kits, and power ends are available
- A variety of seal options and flushing/cooling systems to handle almost all process applications are available
- Sleeved or solid shaft construction available
- Also available: MXP for metal, MTA PFA-lined, and MTE ETFE-lined models - all ANSI/ASME B73.3 sealless, magnetic-drive pumps

MAGNATEX® 3596 Series Specifications

Liquid Temperature	-100°F to +700°F (-73° to 370°C)
Maximum Shaft Deflection	0.002 Inch (0.0508mm)
Connections	150# FF std. or 300# RF Optional
L10 Bearing Life	50,000 Hours
Maximum Working Pressure	275 psig (18.96 bar)
Speed	Up to 3550 rpm (2950 @50hz)
Motor	NEMA or IEC Foot Mounted

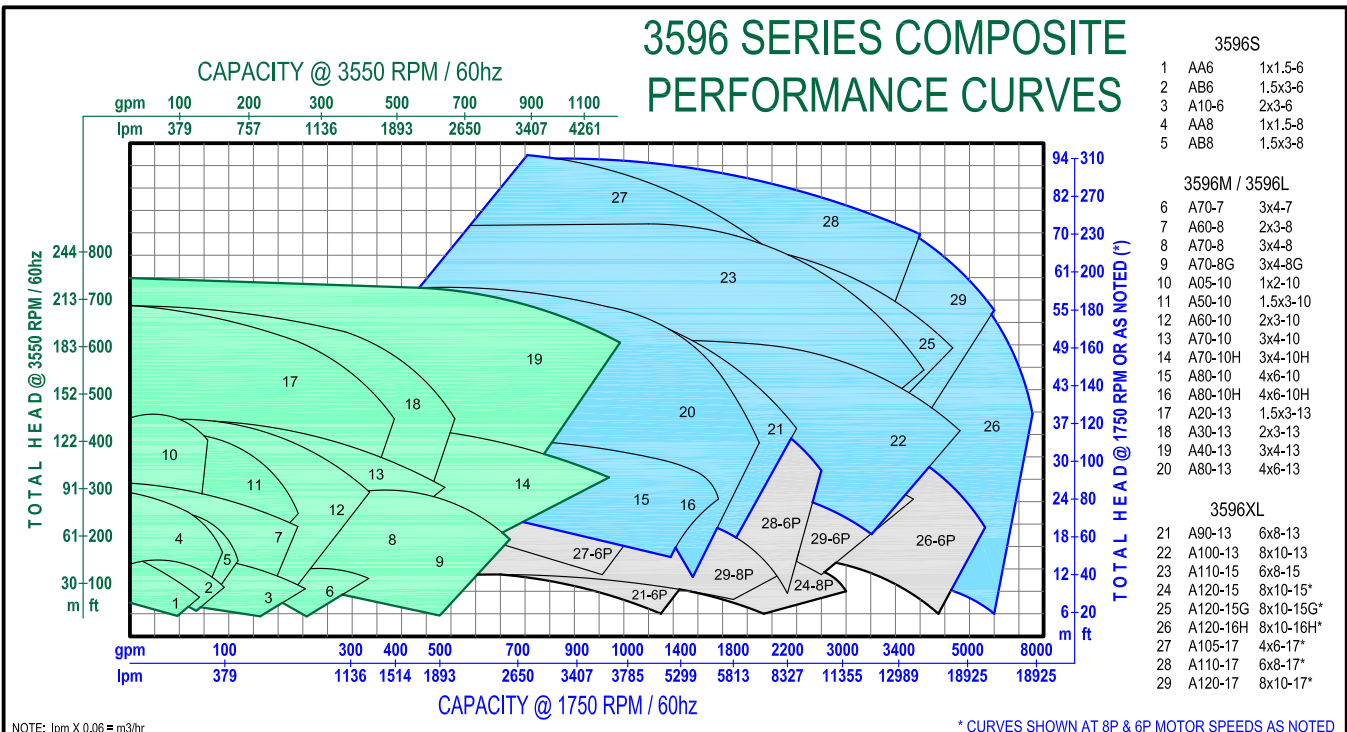

COPYRIGHT 2020 MAGNATEX PUMPS INC.

DIMENSIONAL DRAWING MAGNATEX 3596 SERIES PUMPS

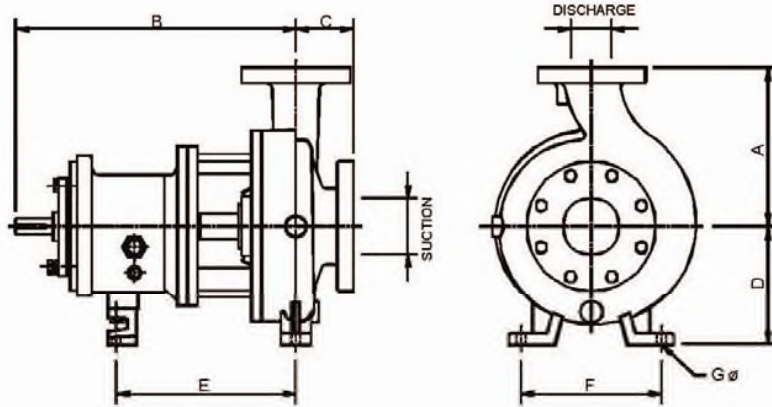

GENERAL DIMENSIONS

FRAME	SIZE	ANSI DESIGNATION	DISCHARGE SIZE	SUCTION SIZE	A	B	C	D	E	F	G BORE	WEIGHT (APPROX.)	
					DIMENSIONS IN INCHES (CENTIMETERS) - NOT FOR CONSTRUCTION -								
MAGNATEX 3596S	1 x 1.5 - 6	AA	1	1.5	6.5 (16.5)	13.5 (34.3)			5.25 (13.3)	7.25 (18.5)	6 (15.2)	.625 (1.58)	84 (38)
	1.5 x 3 - 6	AB	1.5	3								92 (42)	
	2 x 3 - 6	AC	2	3								95 (43)	
	1 x 1.5 - 8	AA	1	1.5								.563 (1.43)	100 (45)
	1.5 x 3 - 8	A8	1.5	3								108 (49)	
MAGNATEX 3596M & 3596L	3 x 4 - 7	A70	3	4	11 (28.0)	19.5 (49.5)	4 (10.2)		8.25 (21.0)	12.5 (31.8)	9.75 (24.7)	.625 (1.58)	220 (100)
	2 x 3 - 8	A60	2	3	9.5 (24.2)								200 (91)
	3 x 4 - 8	A70	3	4	11 (28.0)								200 (91)
	3 x 4 - 8G	A70	3	4	11 (28.0)								200 (91)
	1 x 2 - 10	A05	1	2	8.5 (21.6)								220 (100)
	1.5 x 3 - 10	A50	1.5	3	8.5 (21.6)								220 (100)
	2 x 3 - 10	A60	2	3	9.5 (24.2)								230 (104)
	3 x 4 - 10	A70	3	4	11 (28.0)								265 (120)
	3 x 4 - 10H	A40	3	4	12.5 (31.8)								305 (138)
	4 x 6 - 10	A80	4	6	13.5 (34.3)								305 (138)
	4 x 6 - 10H	A80	4	6	13.5 (34.3)								305 (138)
	1.5 x 3 - 13	A20	1.5	3	10.5 (26.7)								245 (111)
	2 x 3 - 13	A30	2	3	11.5 (29.2)								275 (125)
	3 x 4 - 13	A40	3	4	12.5 (31.8)								330 (150)
4 x 6 - 13	A80	4	6	13.5 (34.3)	.563 (1.43)	405 (184)							
MAGNATEX 3596XL	6 x 8 - 13	A90	6	8	16 (40.6)	27.9 (70.8)	6 (15.2)		14.5 (36.8)	18.75 (47.6)	16.0 (40.6)	.875 (2.22)	560 (254)
	8 x 10 - 13	A100	8	10	18 (45.7)								670 (304)
	6 x 8 - 15	A110	6	8	18 (45.7)								610 (277)
	8 x 10 - 15	A120-15	8	10	19 (48.3)								740 (336)
	8 x 10 - 15G	A120-15G	8	10	19 (48.3)								710 (322)
	8 x 10 - 16H	A120-16H	8	10	19 (48.3)								850 (386)
	4 x 6 - 17	A105-17	4	6	16 (40.6)								650 (295)
	6 x 8 - 17	A110-17	6	8	18 (45.7)								730 (331)
	8 x 10 - 17	A120-17	8	10	19 (48.3)								830 (376)

COPYRIGHT 2020 MAGNATEX PUMPS INC.



MAGNATEX[®] MTA Series Specifications

Maximum Flow	1,400 GPM
Maximum Head	268 FT
Liquid Temperature	0°F to 250°F (Consult Factory below 32°F/ above 150°F)
Maximum Power	75 HP
Connections	150lb RF Flanges
Bearing	C-PTFE, G-PTFE, SiC, Carbon
Shaft	SiC
Working Pressure	150 psig; 116 psig for A70 & A80 (Consult Factory >150°F)
Impeller	Enclosed
Speeds	Up to 3550 rpm
Magnets	Neodymium
Motor	NEMA or IEC Close Coupled

Also available for appropriate applications: AA8 1x1.5-8 MST with an external flush option for limited solids handling and SiC rear casing for higher temperature operation.

Magnetic Drive PFA lined Pumps MAGNATEX[®] MTA Series

Magnetex Texel MTA Series sealless, mag-drive pumps conform to ANSI B73.3 and feature a mechanically attached, virgin PFA lining that is transfer-compression molded at 1200 psi. The thicker, more uniform, and higher density result offers longer service life than that of typical roto-molded linings. Our sealless designs are ideal for almost all industrial chemical applications, with PFA especially suitable for high purity services. The lined, sealless design helps eliminate "Reportable Release" issues during normal operation.

All Magnetex[®] pumps and spare parts come with a **1-year unconditional** warranty on materials and workmanship.

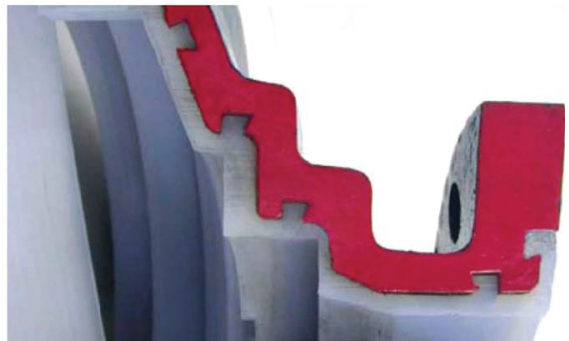

Transfer-compression molding assures positive, interlocking casing linings 5-6mm thick that stay in place; ideal for vacuum and higher temperature applications.

Materials of Construction

- PFA Lined with PTFE/SiC liquid-contact components

MTA SERIES COMPOSITE PERFORMANCE CURVES

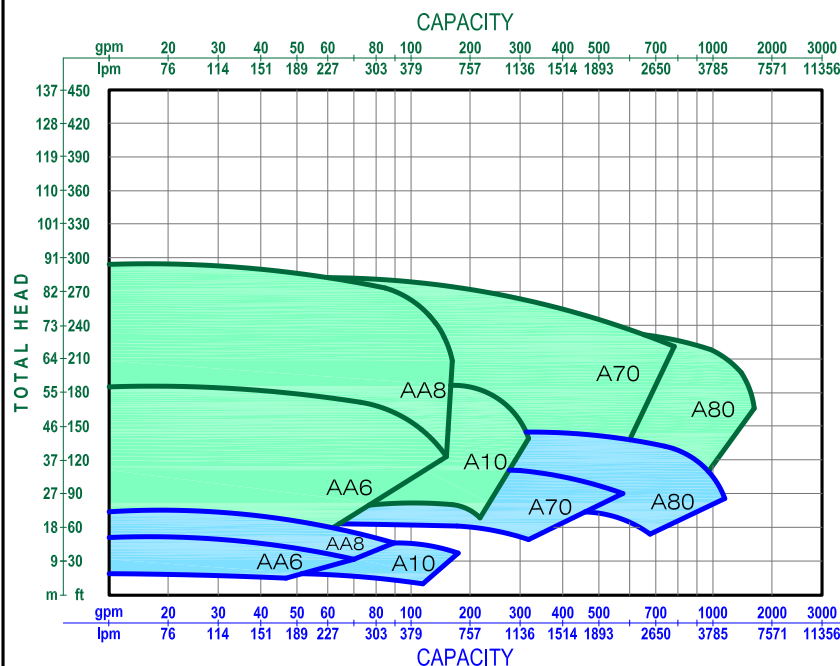

@ 3500 RPM 60hz

MTA-AA6	1x1.5-6
MTA-AA8	1x1.5-8
MTA-A10	2x3-6
MTA-A70	3x4-10 (2865 RPM)
MTA-A80	4x6-10 (2500 RPM)

@ 1750 RPM 60hz

MTA-AA6	1x1.5-6
MTA-AA8	1x1.5-8
MTA-A10	2x3-6
MTA-A70	3x4-10
MTA-A80	4x6-10

MTA Internal Flow Path

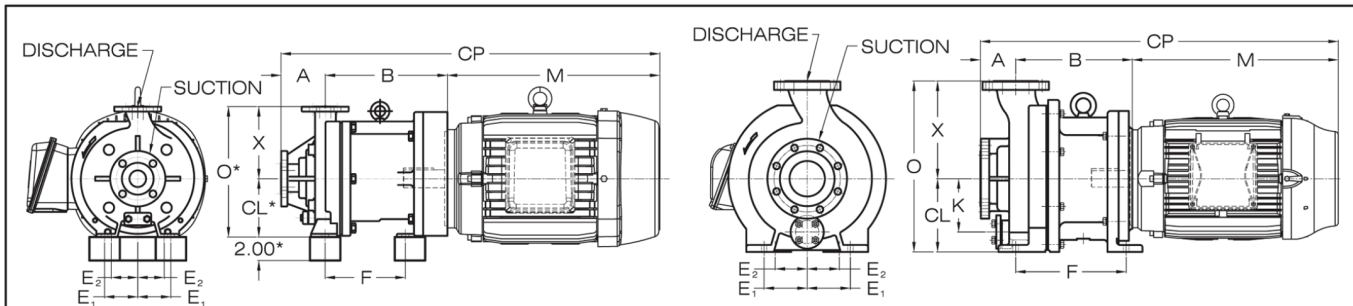
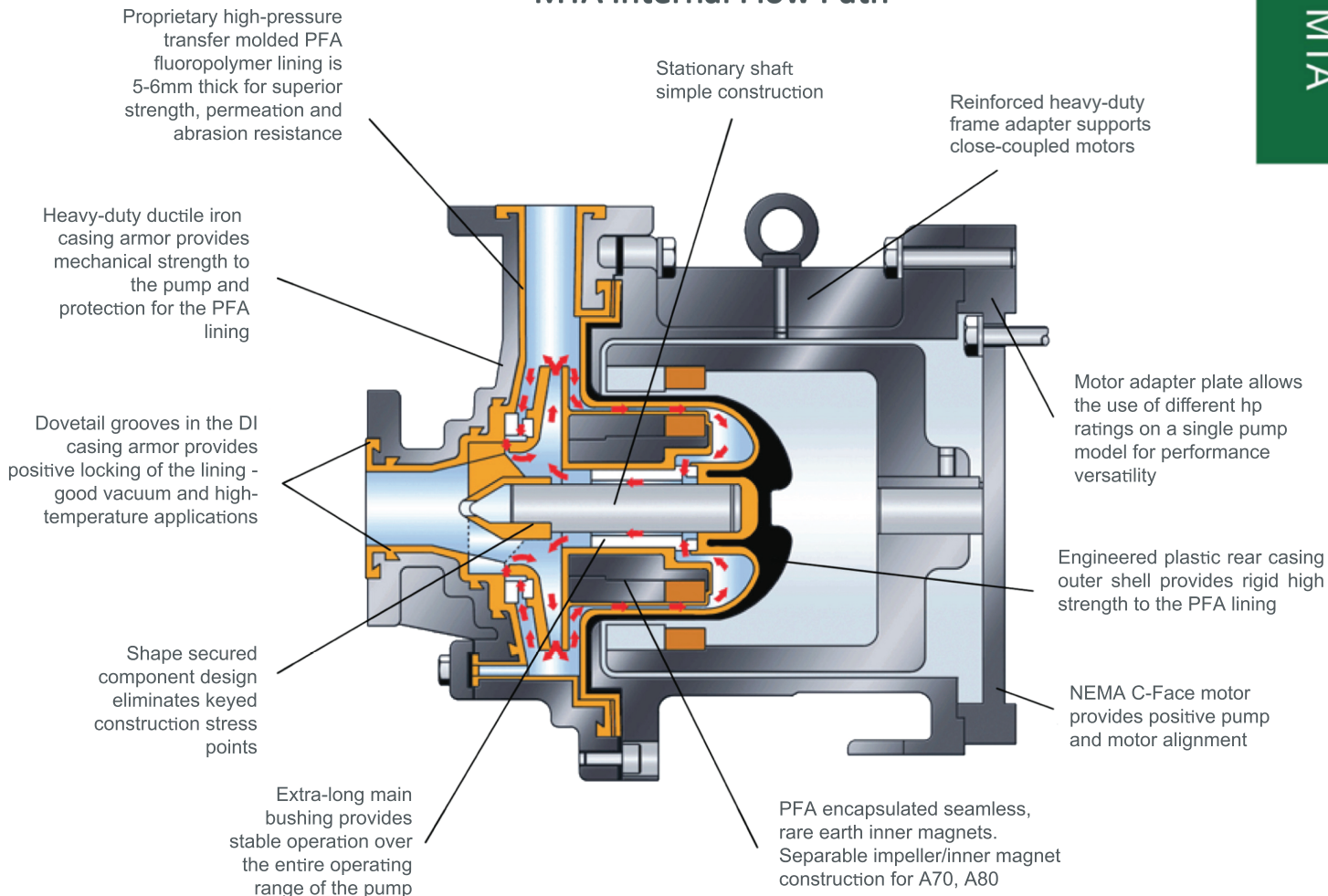

* ADD 2.00" FOR PUMP RISERS TO CL AND O DIM FOR MOTOR FRAME 213TC OR GREATER FOR AA6/AA8 ONLY

STANDARD F1 CONDUIT BOX SHOWN FOR ILLUSTRATION ONLY. OTHER LOCATION MUST BE SPECIFIED.

MODEL	DIMENSIONS (ALL DIMENSIONS IN INCHES ± 0.12")											NOT FOR CONSTRUCTION				
	S	D	A	B	E ₁	E ₂	F	K	X	CL	O	PUMP LBS	VARIES BY MOTOR MANUFACTURER			
													M	CP	MTR LBS	
MTA-AA6	1.50	1.00	4.00	9.96	3.00	-	7.55	-	6.50	5.25	11.75	231	143/5TC	11.11	25.07	51
													182/4TC	13.11	27.07	93
													213/5TC	16.14	30.10	172
MTA-AA8				11.06								238	254/6TC	20.95	36.01	344
													284/6TSC	23.31	38.37	474
MTA-A10	3.00	2.00	4.00	10.24	4.88	3.63	11.33	-	8.25	8.25	16.50	253	143/5TC	11.11	25.35	51
													182/4TC	13.11	27.35	93
													213/5TC	16.14	30.38	172
													254/6TC	20.95	35.19	344
													284/6TSC	23.31	37.55	474
MTA-A70	4.00	3.00	4.00	12.34	4.88	3.63	12.50	6.00	11.00	8.25	19.25	355	213/5TC	16.14	32.48	172
				12.56									254/6TC	20.95	37.51	344
				13.19									284/6TC	23.31	40.50	474
				13.82									324/6TC	25.87	43.69	584
				12.57									254/6TC	20.95	37.52	344
MTA-A80	6.00	4.00	4.00	13.19	4.88	3.63	12.50	6.90	13.50	10.00	23.50	445	284/6TC	23.31	40.50	474
				13.82									324/6TC	25.87	43.69	584

COPYRIGHT 2020 MAGNATEX PUMPS INC.

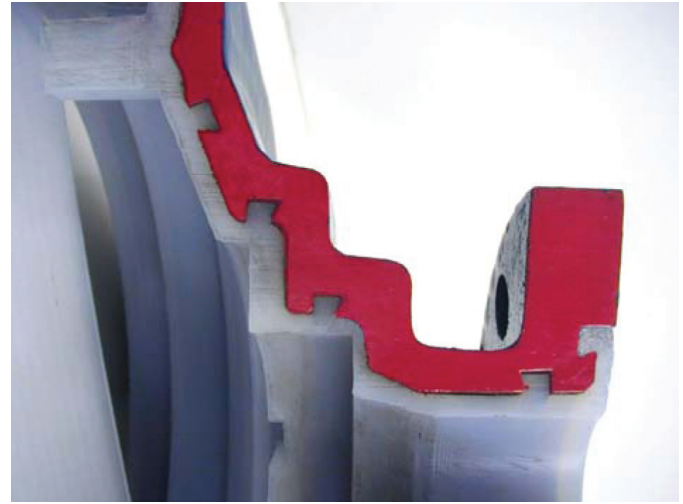

TEXEL[®] PFA Lined MTA Series Pump Features

- PFA (Perfluoroalkoxytetrafluoroethylene) is a high-strength, high-temperature and abrasion-resistant fluoropolymer material
- Standard lining thickness is 5-6 mm
- PFA lining is mechanically secured to the ductile iron casing armoring by means of recessed dovetails that are cast into the ductile iron casing armor
- Extra long main shaft bushing
- Proprietary high pressure (1200 psi) transfer compression molding process
- Completely seamless inner magnet lining.

Competitive Comparator

MAGNATEX	COMPETITION
PFA offers the broadest range of resistance to chemical attack, lowest permeation rate and highest temperature capability of all the fluoropolymer materials, which ensures the maximum possible service life for Magnatex [®] lined magnetic drive pumps.	Generally only available in cheaper ETFE (Ethylene Tetrafluoroethylene) material, which has less chemical resistance, higher permeability and lower temperature resistance than PFA.
Magnatex PFA linings are 5–6mm thick and therefore will last longer in service than thinner ones of the same material and even longer when compared to the ETFE and PVDF linings offered by most of our competitors.	Most competitors' linings are just 3–4 mm thick, which means they have proportionately less corrosion and permeation resistance than Magnatex lined pumps.
High-pressure molding at 1200 psi produces a positive locking of the lining material and prevents lining movement in high vacuum or low suction pressure applications.	Most competitors have no mechanical means of restraining the casing liner, which can result in lining movement in high vacuum or low suction pressure applications. Shifting or movement of the lining may result in linings collapsing onto the internal rotating elements leading to catastrophic failure of the pump.
The extra long main shaft bushing provides greater stability for operation across the entire hydraulic range of the pump, with smooth, quiet operation and extremely low vibration. Greater shaft support surface area means lower hydraulic loading, less wear and longer service life	Competitors generally offer shorter main shaft bushings, resulting in a smaller surface area to support dynamic shaft loads, which results in a shorter pump life.
High-pressure transfer molding @ 1200psi produces a lining with a dense, uniform thickness and superior surface finish, all of which contribute to superior service life in demanding chemical services. High pressure molding also eliminates any air pockets between the casing lining and the armoring, which is critical in high temperature services.	Competitors use a cheaper, atmospheric pressure, rotomolding process, which results in a thinner, less dense, and more permeable lining material with a less uniform surface finish. Rotomolded linings may have air bubbles trapped behind them, which can lead to linings cracking in high-temperature applications.
Completely seamless inner magnet lining eliminates a potential leak path for the process fluid to reach and attack the inner magnet. Shape secured main bushing eliminates keyed construction; easing related stress points.	Most competitors have seams in the inner magnet lining that can allow aggressive chemicals to penetrate the lining, which cause the magnet segments to swell and corrode, leading to catastrophic failure of the pump.

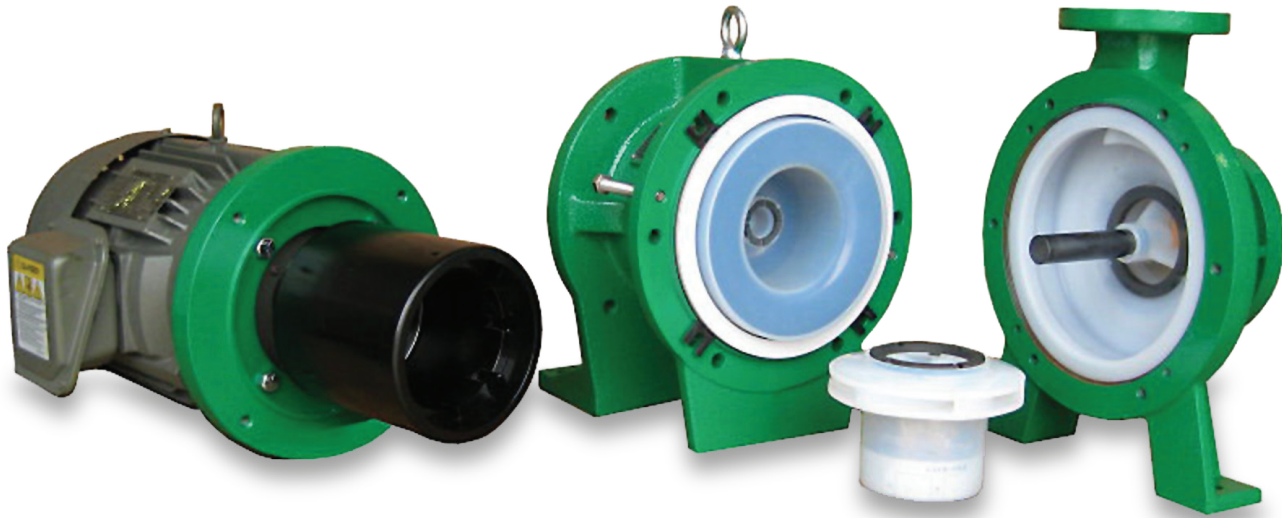
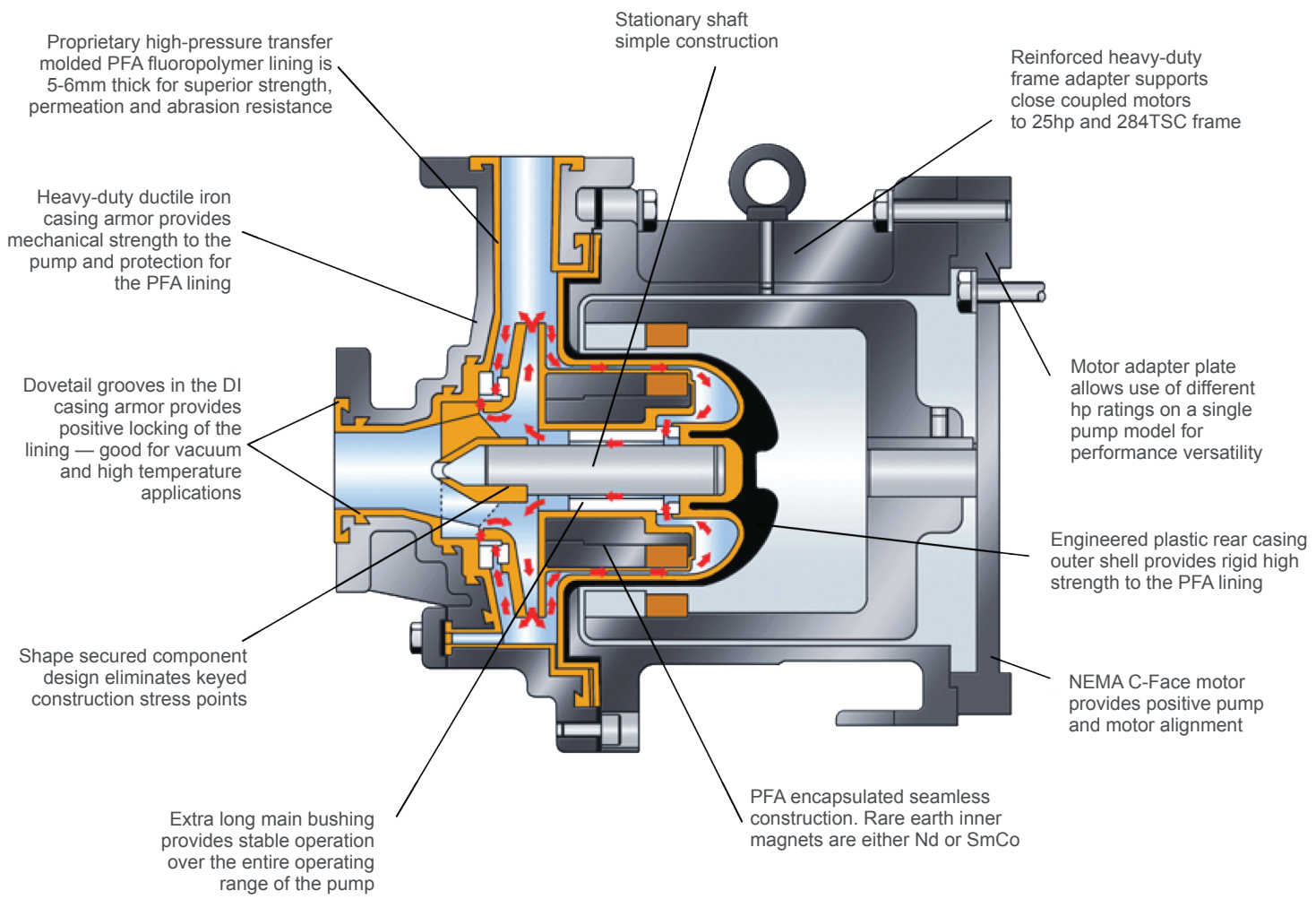

COPYRIGHT 2010 MAGNATEX PUMPS, INC.



Materials of Construction:

- ETFE Lined
- Kynar[®] (PVDF) Lined.
Registered trademark
of Arkema, Inc

Magnetic Drive Fluoropolymer Lined Pumps

MAGNATEX[®] ME Series

Magnatex[®]/ Texel[®] ME Series sub-ANSI pumps are dependable, durable, replaceable liner, magnetic drive pumps. They are the solution for low to medium flow, corrosive fluid applications. These pumps provide a lifetime of maintenance-free operation with low initial cost and low total cost of ownership. Replaceable liners make repairs easy and inexpensive without special tooling required. Sealless design helps eliminate "Reportable Release" issues.

MAGNATEX[®] ME Series Specifications

Maximum Flow	90 GPM
Maximum Head	140 FT
Liquid Temp	32°F to 195°F
Maximum Power	3 HP
Connections	125 lb RF Flanges
Bearing	C-PTFE, G-PTFE, SiC, Carbon
Shaft	Ceramic SiC
Maximum Working Pressure	70 psig
Impeller	Enclosed
Speeds	Up to 3550 rpm
Magnets	Rare Earth
Motor	NEMA or IEC Frame Mounted

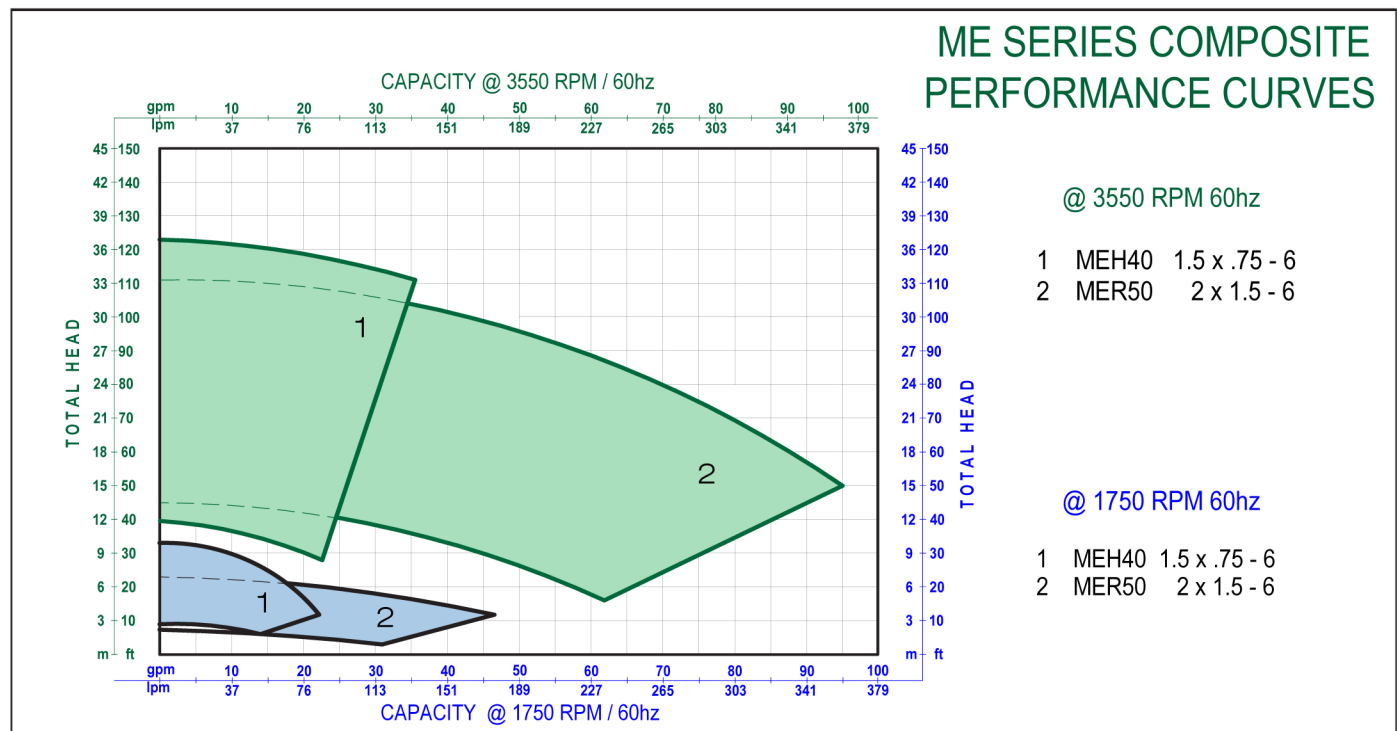

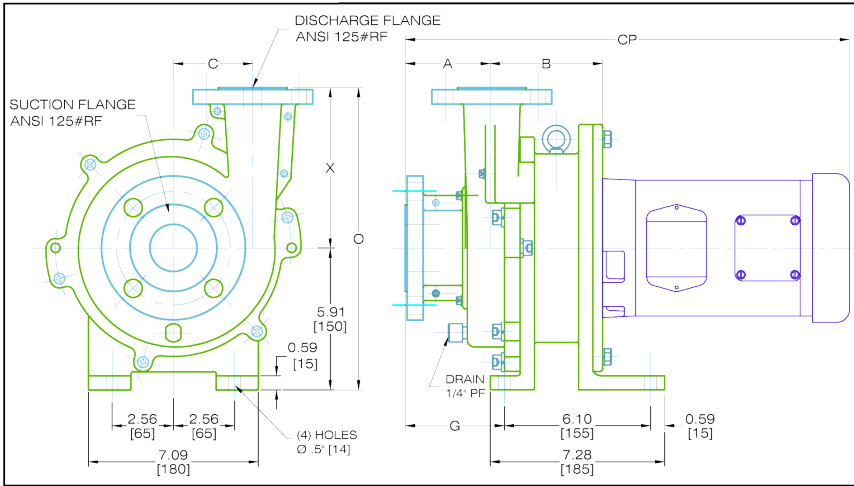
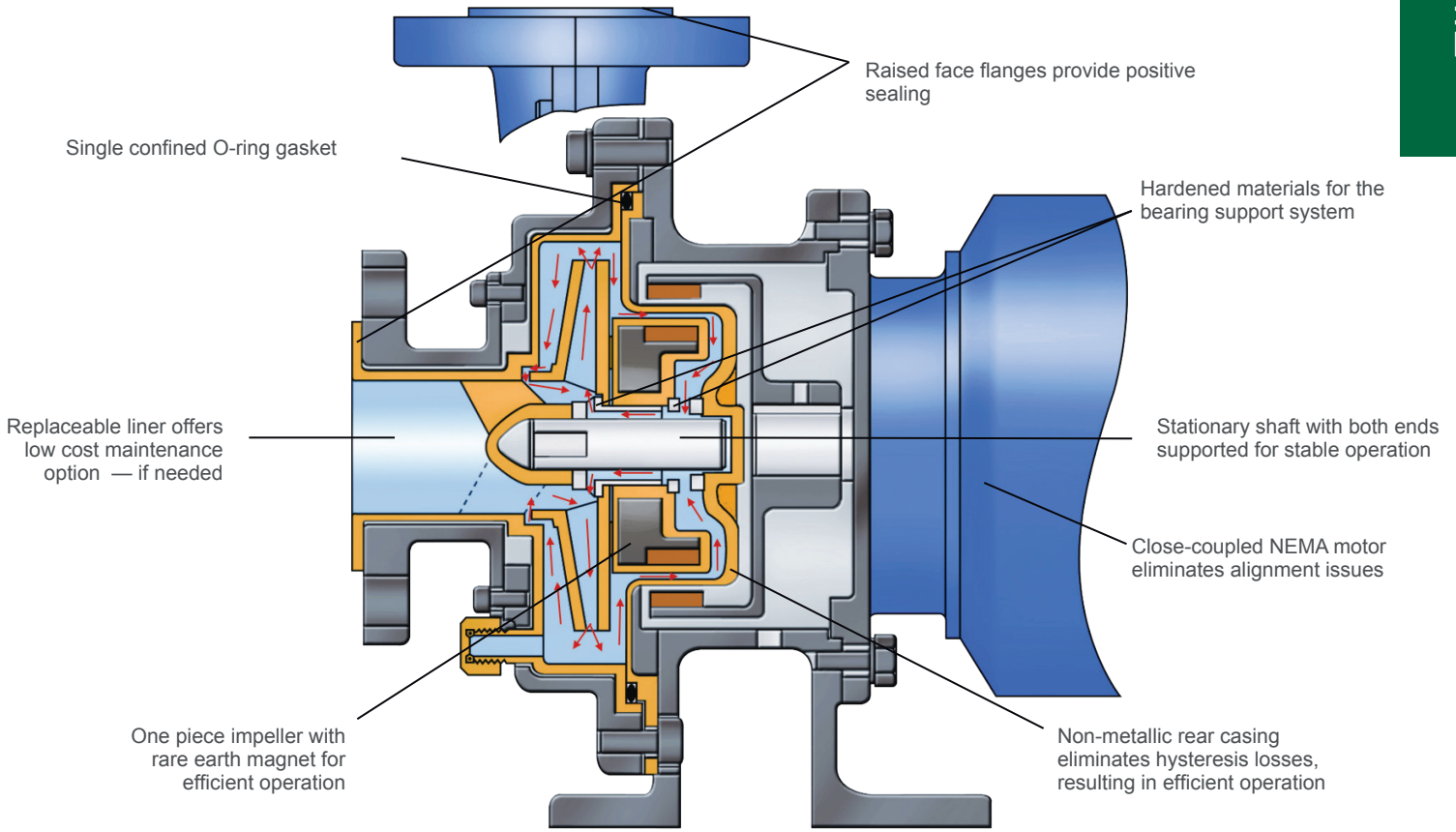

NOT FOR CONSTRUCTION

CONDUIT BOX SHOWN FOR ILLUSTRATION ONLY
REQUIRED LOCATION MUST BE SPECIFIED

MAGNATEX[®]
Pumps, Inc.

PUMP DIMENSIONS
MEH/MER SERIES CLOSE-COUPLED PUMPS

DRAWN BY: B VALENTIN	DATE: 10/21/10	SCALE: NTS	PAGE: 1 OF 1
-------------------------	-------------------	---------------	-----------------

DD-MEH/MER SERIES R1

ALL DIMENSIONS ± 0.12" [3mm]

MODEL	MOTOR FRAME		DIMENSIONS in INCHES [MILLIMETERS]								APROX. WEIGHT		
	NEMA	IEC	S	D	CP	O	A	C	X	B	G	PUMP	MOTOR
												lbs. (kgs.)	lbs. (kgs.)
MEH-40 1.5 x .75 x 6	56C	63 - 80	1.5"	0.75"	18.45 [465]	12.64	3.54	3.31	6.70	4.62 [117.5]	3.85 [98]	58 (26)	31 (14)
	143TC	90S			18.73 [476]					4.68 [119]			54 (24)
	145TC	90L			19.24 [489]					5.03 [128]			58 (26)
	182TC	112S			20.68 [525]					5.03 [128]			99 (44)
MER-50 2 x 1.5 x 6	56C	63 - 80	2.0"	1.5"	18.61 [473]	12.60	3.46	2.79	6.74	4.86 [123.5]	3.97 [101]	55 (25)	31 (14)
	143TC	90S			18.89 [480]					4.92 [125]			54 (24)
	145TC	90L			19.40 [493]					5.66 [144]			58 (26)
	182TC	112S			21.23 [539]					5.66 [144]			99 (44)

COPYRIGHT 2010 MAGNATEX PUMPS, INC.

Magnetic Drive Sealless Polypropylene Pumps

MAGNATEX[®] MEP Series

Magnetic drive, sealless, medium-duty, polypropylene thermoplastic pumps, designed for chemical transfer applications. Simple construction allows for economical first cost and ease of maintenance. Sealless design helps eliminate "Reportable Release" issues.

Call us today at 713-972-8666 or 1-866-624-7867

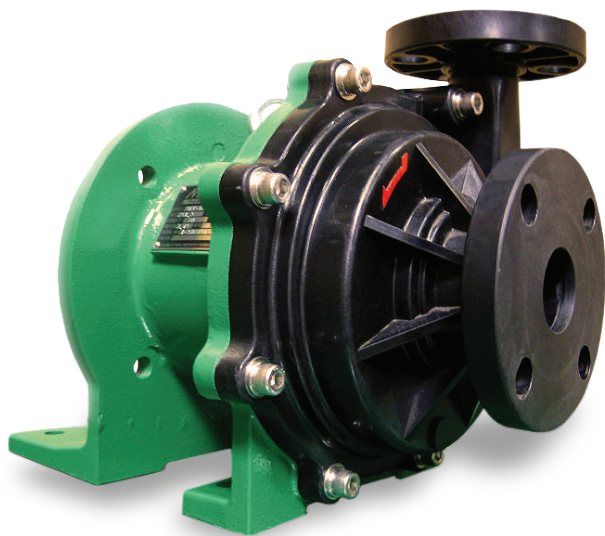

MAGNATEX[®] MEP Series Specifications

Maximum Flow	106 GPM
Maximum Head	103 FT
Liquid Temperature	Max 175° F
Maximum Power	5 HP
Connections	Drilled for DIN and ANSI Flanges
Bearings	Carbon, C-PTFE
Shaft	Ceramic
Maximum Working Pressure	55 psig
Impeller	Enclosed
Speeds	Up to 3550 rpm
Magnets	Rare Earth
Motor	NEMA or IEC Frame Mounted

Materials of Construction:

- Polypropylene

MEP SERIES COMPOSITE PERFORMANCE CURVES

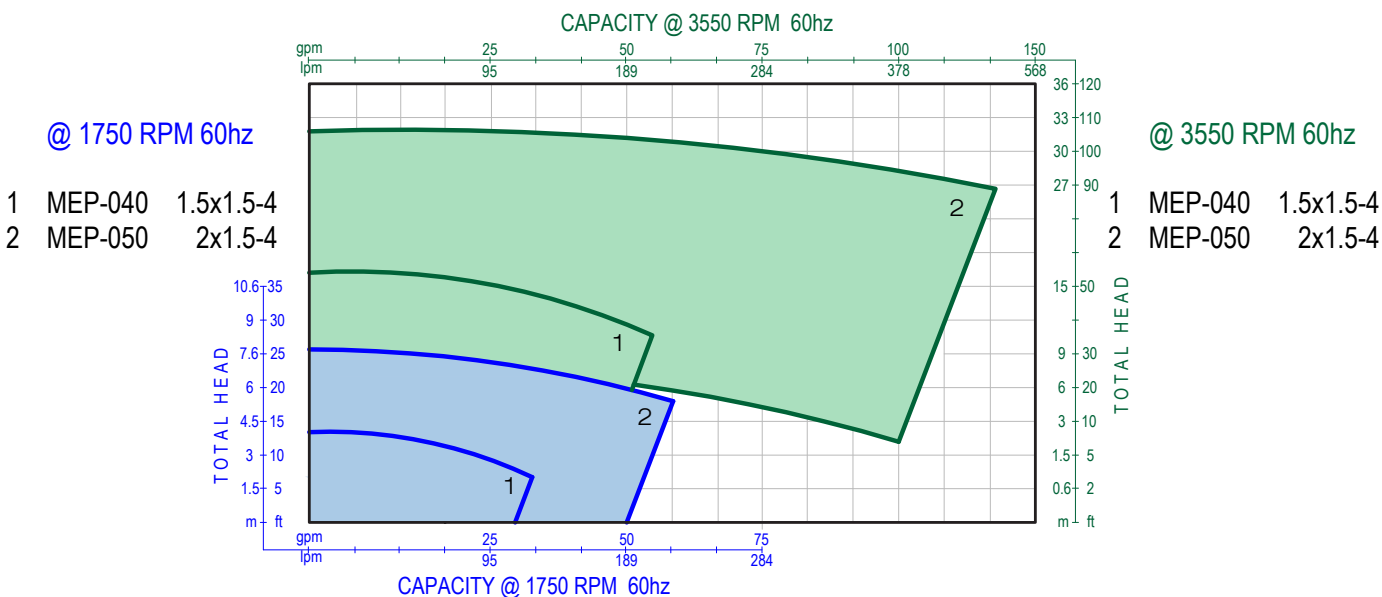

MAGNATEX®

MEP SERIES PUMPS

PARTS	SHAFT			BEARING				REAR CASING			O-RING		
	Alumina	SiC	Titanium	Carbon	C-PTFE	G-PTFE	SiC	G-PP	C-PVDF	C-ETFE	FMP	EPDM	AFLAS®
MEP-402	●			●	●			●			●	●	*
MEP-404	●			●	●			●			●	●	*
MEP-502	●			●	●			●			●	●	*
MEP-504	●			●	●			●			●	●	*
MEP-506	●			●	●			●			●	●	*

Standard ●
Optional *

CONDUIT BOX SHOWN FOR ILLUSTRATION ONLY
REQUIRED LOCATION MUST BE SPECIFIED

DIMENSIONAL DRAWING
MEP SERIES ANSI PUMP

DRAWN BY: B VALENTIN DATE: 07/01/10 SCALE: NTS PAGE: 1 OF 1

DD-MEP SERIES

ALL DIMENSIONS IN INCHES ± 0.12"

NOTES:
1. FLANGES ARE 150# DRILLED FOR DIN & ANSI DIMENSIONS
2. MAXIMUM WORKING PRESSURE IS 55 psig
3. MAXIMUM WORKING TEMPERATURE IS 175°F / 79.4°C
4. VERIFY WORKING PRESSURE AT PUMPING TEMPERATURE

NOT FOR CONSTRUCTION

MODEL	MOTOR FRAME	DIMENSIONS																APROX. WEIGHT lbs.	
		S	D	A	B	C	CL	X	E	F	G	H	I	J	K	M	CP	PUMP	MOTOR
MEP-402	56C	1.50	1.50	3.26	7.08	2.48	4.53	5.71	2.56	7.09	6.00	0.47	1.38	5.28	0.79	10.29	20.63	24	67
MEP-404		1.50	1.50													10.23	20.57		
MEP-502	145TC	2.00	1.50	3.66	7.20	3.39	5.51	6.61	2.95	7.87	6.85	0.59	1.57	5.37	0.79	10.23	21.09	42	99
MEP-503	182TC	2.00	1.50		7.95											12.02	23.63		
MEP-506	184TC	2.00	1.50											7.36	1.06	13.01	16.67		108

COPYRIGHT 2010 MAGNATEX PUMPS, INC.



PA/PB Assemblies

PA/PB Assemblies cost a fraction of the sum of their component parts, so that they are the most cost effective way to spare your critical Magnatex pump(s).



(Fig. 1) Wet End Assembly (PB)



(Fig. 2) Outer Magnet Assembly

A PB Assembly is a completely assembled wet end rotating element (Fig. 1) consisting of the rear casing, inner magnet, Sic(X) bearing system and impeller. A PA Assembly consists of the PB Assembly **PLUS** the outer magnet assembly (Fig. 2).

PA/PB assemblies are the quickest and easiest way to get your process back up and running with minimal downtime and lost production. As an added benefit, once the old assembly has been removed from the pump you can purchase whatever spare components you need to repair it and put it back into your spares inventory for future use.



Patented SiC-XSM Dry Run Resistant Bearings

Significantly increased dry-running capability!

- Our SiC-X bearings can run dry for extended periods — even hours!
- Unique materials and manufacturing techniques of our specially treated SiC-X bearings provide a coefficient of friction 1/4 that of SiC
- The very low coefficient of friction of our SiC-X bearings results in much less heat being generated in upset or dry-running conditions. SiC-X bearings are more forgiving of dry-running conditions frequently encountered at start-up, during upset conditions or in batch services. Extremely hard surfaces minimize wear and prolong service life; resistance to chemicals is maintained for extended bearing life.

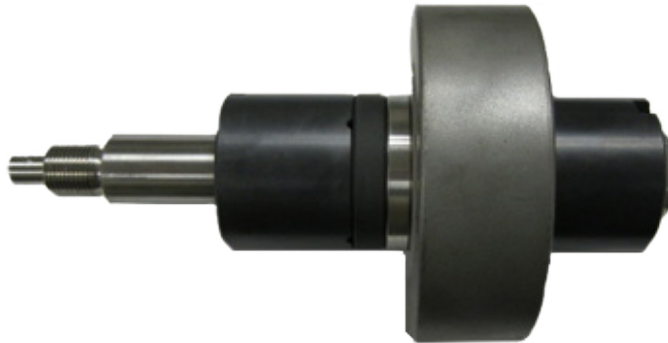

SiC-X Availability

MMP/MMH/MML—Standard
 MP/ML/MPH/MPT—Standard
 MPL/MLL/MHL—Optional
 MAXP—Optional

Preliminary Test Results

- In multiple dry-running tests using an MP220, 1 HP unit with standard SiC bearings, noise developed after a brief period of operation. On disassembly, internal damage was identified. The same pump with the special bearing material operated over 1 hour and 45 minutes with no unusual noise. On disassembly, there was no visible damage.
- The next test involved running the same pump with the SiC-X bearing material dry for one hour with the suction valve closed. The rear casing temperature reached 260°F. With the pump still operating, the suction valve was then opened, allowing room temperature water to enter the pump; continued to operate. On inspection, no damage or cracks were observed – all parts were in excellent condition.
- A test at a customer facility was inadvertently run when the suction cap used during shipping was not removed before installation. After running dry for 10 minutes, the pump was inspected and no damage was observed. The pump was reinstalled without the cap and operated as expected.

Test Progression	Standard SiC	SiC-X
	Coefficient of Friction = 0.39	Coefficient of Friction = 0.099
Operation with a combination of air and liquid; rotation speed of 19.7ft/sec and weight on bearing of 8.2 lbs.	The bearing surface was abraded with noticeable wear after operating for 10 minutes	Bearing was in excellent condition after 10 minutes of operation
Dry-running—no liquid; 19.7 ft/sec, 8.2lbs	Bearing damage after 2 seconds of operation	Bearing was in excellent condition after 80 seconds
Dry-running—no liquid; 15.4 ft/sec, 2.2lbs	Bearing damage after 45 seconds of operation	Bearing was still in excellent condition after 1 hour and 45 minutes of operation
Heat shock after dry-running 1 hour; poured water at room temperature on bearing which was assumed over 330°F	N/A—will not run dry this long	Bearing was still in excellent condition; no thermal cracking or heat checking evident

Liquid	Temperature degrees °F	Time	Degrees of Corrosion (g/m2/hr)
65% HNO ₃	Boiling	24 Hours	0.003
100% H ₂ SO ₄	Boiling	24 Hours	0.002
35% HCl	Boiling	24 Hours	0.002
30% NaOH	Boiling	24 Hours	0.002
100% CH ₃ COOH	158°F	24 Hours	0.000
35% H ₂ O ₂	Boiling	24 Hours	0.002

In the case of the test application involving air with liquid, an inherently difficult situation for product lubricated bearings, the SiC-X bearing operated continuously for 10 minutes with no cracks or wear. Even with completely dry operation -- no liquid whatsoever, the SiC-X bearings operated for considerably longer time than SiC bearings. Inspection revealed the bearings to still be in good condition after 1 hour 45 minutes.

Conclusions

- One of the weak points of ceramic materials is poor response to thermal shock. In our tests, the SiC-X bearing material was unaffected. On inspection, the bearing showed no evidence of damage. The results of a similar, though inadvertent, field test where a technician discovered the pump was being operated in a dry-running condition were equally impressive. He stopped the pump and poured liquid on the bearing to cool it off quickly. Even in that situation with the bearing close to the point of being damaged, the SiC-X gave the customer good results. The technician “expected damage” and was surprised to see the SiC-X in good condition.
- As indicated in the corrosion testing chart above, SiC-X had comparable performance to that of SiC as shown in various literature sources for the listed chemicals

Summary

- From our testing and analysis, it is clear that the SiC-X provides good results when used in magnetically-driven pumps, especially for troublesome, startup dry-running conditions. The benefits don't stop there! We can expect better performance in the case of upset conditions and other temporary dry-running situations, eliminating or greatly delaying bearing damage where it likely would have immediately occurred with standard SiC.
- The values in the above charts are from actual test results and are considered reliable, though we cannot guarantee similar results. For added protection from dry run conditions we recommend the use of a power monitor for optimal equipment protection.



PMP-25 Pump Load Control Installation, Set-up & Adjustment

The Model PMP-25 monitors the true power going to a motor. By sensing power (volts x amps x power factor) rather than just amps, there is much greater sensitivity. For loss of load detection, this means a 10X improvement in performance.

Mounting:

Wiring is done to un-pluggable terminal strips on the rear of the unit. Three ways to mount:

- On door or raceway – use cutout template
- Panel Mount – use template + optional Bezel Kit (No Charge)
- On wall – on standard outdoor junction box + optional
- Outlet Box Adapter (No Charge)

Voltage:

120 volts AC is taken from two of the phases. If the motor starter already has a 120-volt control transformer with 10VA of free capacity, it can be used. Otherwise, install a separate transformer. It is okay if the secondary is grounded.

BE SURE TO NOTE WHICH TWO PHASES SUPPLY THE TRANSFORMER.

In 120/208V three-phase system, the 120V **MUST** come from a transformer connected to two of the phases. The 120V phase to ground voltage cannot be used.

Current:

The current signal is taken from the REMAINING phase. This current sample passes through the Range Finder Toroid.

It is VERY IMPORTANT that the current signal comes from the phase that IS NOT supplying the 120V control transformer. Be extra careful when the machine has reversing starters or multi-speed windings. If a wrong phase is used the control will either:

- Work backwards
- Have reduced sensitivity

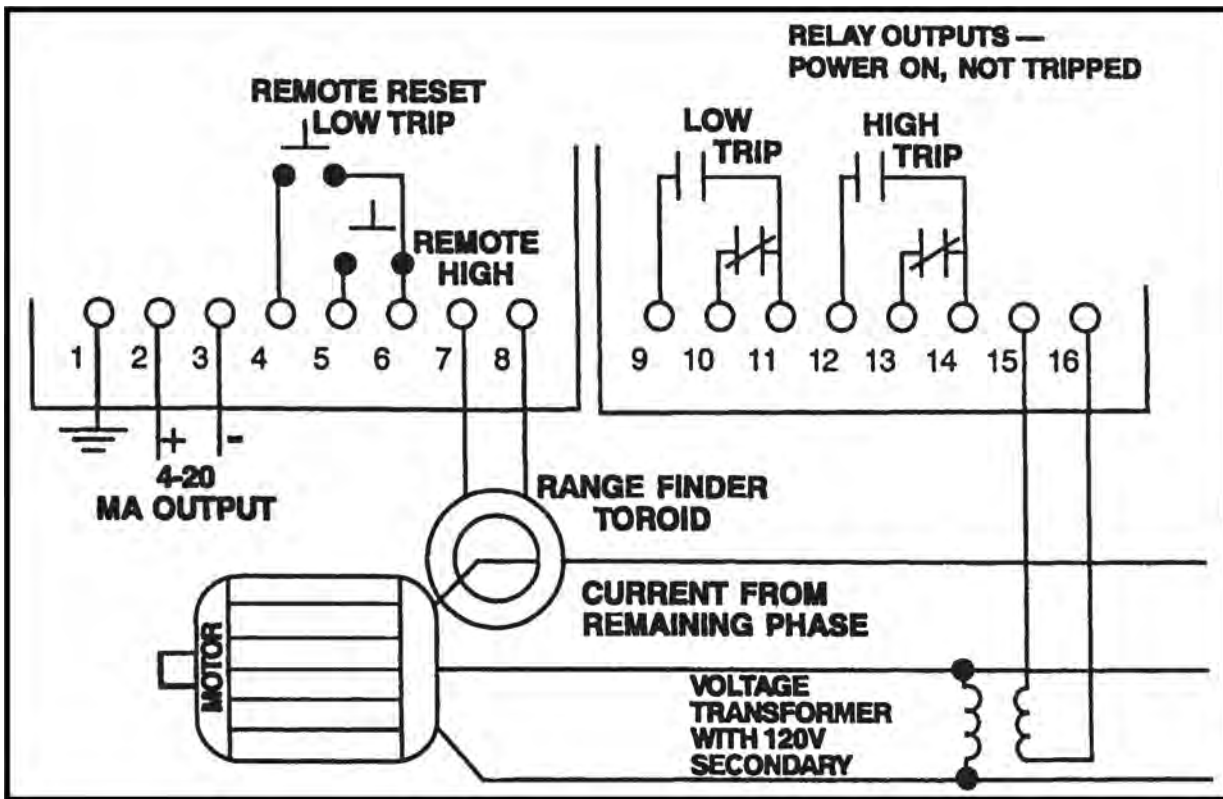

Full Scale Capacity at 460 Volts:

The Range Finder Toroid has six motor size choices. Select one that is equal or larger than your motor. This will leave some headroom.

- For motors less than 5 HP (460 volt), take extra turns.
- For motors greater than 50 HP, use Range Finder Toroid + Current Transformer.

MOTOR SIZE	FULL SCALE CAPACITY	%FULL LOAD	RANGE FINDER SWITCH	TURNS	CURRENT TRANS-FORMER
1/2 HP	.6 HP	123	2 ON	8	
1	1.25	123	2 ON	4	
1-1/2	1.65	109	2 ON	3	
2	2.70	134	2 ON	2	
3	3.80	128	3 ON	2	
5	5.50	110	2 ON	1	
7-1/2	8.25	110	3 ON	1	
10	11.0	110	4 ON	1	
15	27.5	183	5 ON	1	
20	27.5	137	5 ON	1	
25	27.5	110	5 ON	1	
30	55.0	183	6 ON	1	
40	55.0	138	6 ON	1	
50	55.0	110	6 ON	1	
60	84.0	140	1 ON	1	100:5
75	84.0	112	1 ON	1	100:5
100	130	130	1 ON	1	150:5
125	130	104	1 ON	1	150:5
150	173	115	1 ON	1	200:5
200	216	108	1 ON	1	250:5
250	260	104	1 ON	1	300:5
300	346	115	1 ON	1	400:5

Multipliers:

For nominal voltages other than 460 volts, multiply 460V full scale by:

208V = .45
 230V = .5
 380V = .83
 415V = .9
 575V = 1.25

For Kilowatts multiply Full Scale HP x .746

For motor sizes or capacities not in table:

$$\%Full Load = \frac{Full Scale Capacity \times 100}{Your Motor Size}$$

Range Finder Toroid

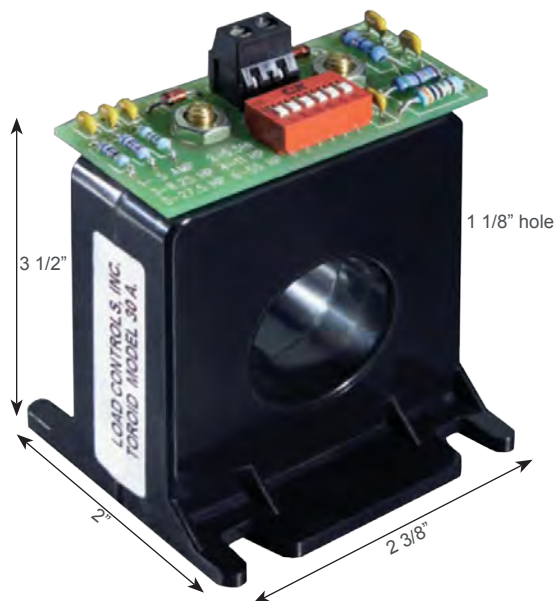

For Motors Less than 5HP

Take more "turns" of the leg through the Toroid. Each time the wire passes through the Toroid is a "turn".

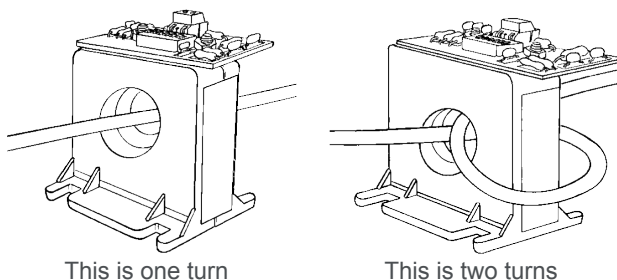

For Motors Greater than 50HP

A Current Transformer is used to reduce the primary current. The 5-amp secondary passes through the Toroid.

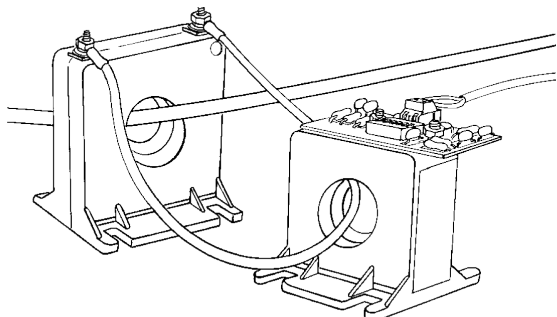

Pass secondary of CT through toroid

CAUTION

When current is flowing through the primary of the external current transformer, always have a wire between the two brass Terminals on the CT.

If they are left open, dangerous and destructive voltages can develop.

Hooking up the Rest

Control can be reset three ways:

- Manually with the Reset button on the control.
- Remotely with a remotely located reset button or relay.
- Automatic with a jumper

Remote Reset-

Momentarily connect Terminal 4 to Terminal 6 for low
Momentarily connect Terminal 5 to Terminal 6 for high

Automatic Reset-

Jumper Terminal 4 or 5 to Terminal 6

The terminals for Reset generate a small amount of current (8-12 milliamps). To reset, you just need to connect the terminal to the circuit common (Terminal 6).

The switches or relays that you use must be suitable for low current (Gold flashed contacts, Reed Relays, Mercury Switches).

4-20 Milliamp Analog Output

The switches or relays that you use must be suitable for low current (Gold flashed contacts, Reed Relays, Mercury Switches).

Terminal 2	4-20mA	Positive
Terminal 3	4-20mA	Negative

Use twisted pair or in noisy environments, use shielded cable. Ground shield at other end.

Use the Full Scale capacity from the chart to scale external meter, chart recorders or computers.

THE PMP-25 Powers the 4-20MA Signal Do NOT Use an External DC Power Supply

SPECIFICATIONS PMP-25

ENCLOSURE

Glass-filled Polycarbonate
NEMA 4, 4X - STYLE
(3 1/4" x 6 1/4" x 2")
(83 mm x 160 mm x 54 mm)

ANALOG OUTPUT

4-20mA; powered by the
PMP-25 500 OHM
maximum connected impedance

CAPACITY

To 50 horsepower directly
through Toroid
To 500 horsepower with external
Current Transformer & Toroid

RESPONSE TIME

500 Milliseconds

TEMPERATURE

0°C - 55°C

TIMERS

Start-up - 0-999 seconds
(16.7 minutes) adjustable
Low Trip Delay - 0-999 seconds
(16.7 minutes) adjustable
High Trip Delay - 0-999 seconds
(16.7 minutes) adjustable



DIGITAL LOAD DISPLAY

.4" LED 3 Digit





RELAY OUTPUTS

(2) Form C 3 AMP @ 300 VAC or
1/8 HP @ 240 VAC
Latch when tripped

TO SET FULL SCALE

- After hook-up, find your HP, KW or % from the chart.
- Decide if you want to display HP, % or KW.
- The  cycles through the choices shown below and blinks slowly for each choice. Each press  moves you to the next choice.

FRONT PANEL SET-UP TIPS

- 1) None of the settings will be changed until you hold down  and the fast blinking stops.
- 2) Five seconds after you have pressed a button, the control will return to normal operation.
- 3) If you hold down the   digits will continue to change.
- 4) You only need to do  when you install the PMP-25 (or if you change the hook-up).

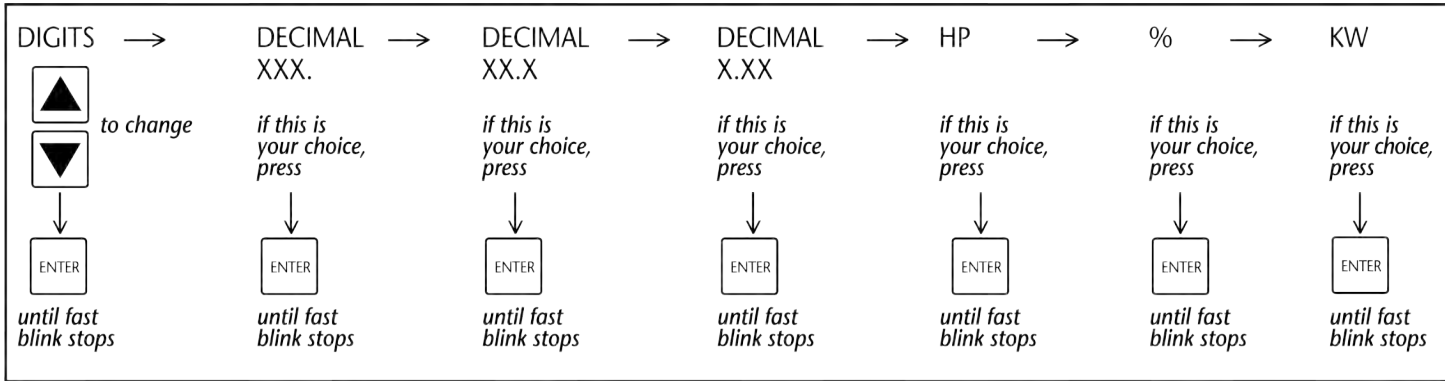

ADJUSTMENTS

- SET POINT - HIGH: The HIGH relay will switch when the load is above the HIGH.
- SET POINT - LOW: The LOW relay will switch when the load is below the LOW.

Start-up Timer

The Start-up Timer bypasses the Control during motor startup to avoid false trips because of current inrush. For convenience, the TIMING BEGINS WHEN THE MOTOR STARTS. The Start-up LED stays lit until the start-up period is over.

The start-up time should be:

- Long enough so that the load has stabilized.

Delay Timers

To avoid nuisance trips from short overloads, Delay Timers bypass the Control for the selected time. The relays won't trip until the time is exceeded. If the trip condition goes away before the time is up, the timer resets to zero.

- Start with minimum Delay. If you are getting trips where you don't want them, increase the Delay Time.

TO VIEW AND CHANGE THE SET POINTS AND DELAY TIMES

 cycles through the choices. The LED for each choice will turn ON.

To change a setting, use



Press ENTER until quick blinking stops to store your new choice.

After 5 seconds if you haven't pressed any buttons, control will return to normal operation.

ADJUSTMENT TIPS FOR CENTRIFUGAL PUMPS

From Pump Curves
Use the recommended minimum and maximum flows and horsepower for your initial set points.

—OR—

Actual Operation

- Low Trip - Run the pump with the OUTLET valves closed. This is the minimum flow. Set the low trip about here.
- High Trip - Run the pump with all valves wide open. This is the maximum flow. Set the high trip about here.
- Make adjustments if you get nuisance trips

Metallic Sealless Magnet Drive Pumps Handle Solids

Can mag-drive pumps handle this pumpage?



Magnatex has the answer!



Rear casing with anti-vortex baffles

Many users of standard sealed, process pumps become frustrated with the high cost of frequent seal replacement and downtime when handling solids. A suitable flushing arrangement might help a sealed pump, but the advantages of sealless pumps are now available for many of these applications!

Like the faces of seals in a sealed pump, sealless pump sleeve bearings and thrust rings are lubricated with the process fluid. Magnatex has developed provisions to allow solids pumping, making the total cost of mag-drive pump ownership lower than sealed pumps.

Magnatex's metallic, standard design pumps are typically limited to 1% by weight of 500 micron solids or up to 5% of 100 micron particles. The simplest way to limit larger solids and higher concentrations is to use a 40 mesh strainer on the suction. Unfortunately, this can result in the strainer plugging, which can result in "starving" the pump suction and subsequent failure of the pump.

What happens if higher concentrations of solids go through a mag-drive pump? If solids percentage or size exceeds our recommended values, provisions must be made to allow use of our pumps because:

1. Solids laden pumpage is not a good lubricant and can foul bearing flutes, resulting in inadequate bearing flush
2. Solids can also become caught in vortices that form near the bottom of rear casings, acting like a small machine tool, ultimately resulting in a containment breach (see photo below).

- Magnatex utilizes a "Baffle-plated," anti-vortex rear casing that breaks up solid laden vortices, that can lead to a rear casing breach; this option is available with our MPL/MML/MPH and MAXP/MAXC product lines
- Either self-cleaning strainers or cyclone separators can be mounted in the discharge line with a side stream of clean liquid product flush introduced to a port in the rear casing. With this configuration the internal flush ports are plugged to keep solids out of the rear casing. This option is available with the MAXP/MAXC series of pumps. This system will not disrupt the process as there is no product dilution and solids simply continue down the discharge pipe in the same concentrations as they entered the pump
- Another option in conjunction with plugging of the internal flush ports is to introduce a clean, compatible liquid to the rear casing, but care must be taken to avoid product dilution that could upset the process



Rear casing breach caused by solids-laden vortices

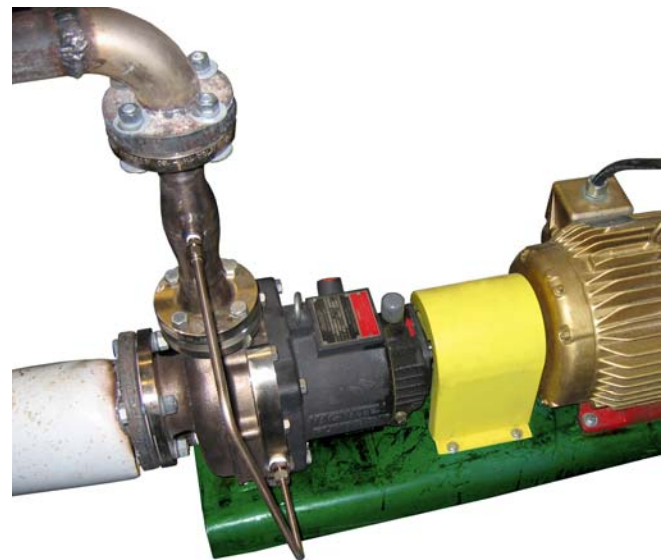

Installation with self-cleaning strainer on discharge which provides clean liquid to the rear casing ceramic bearings system

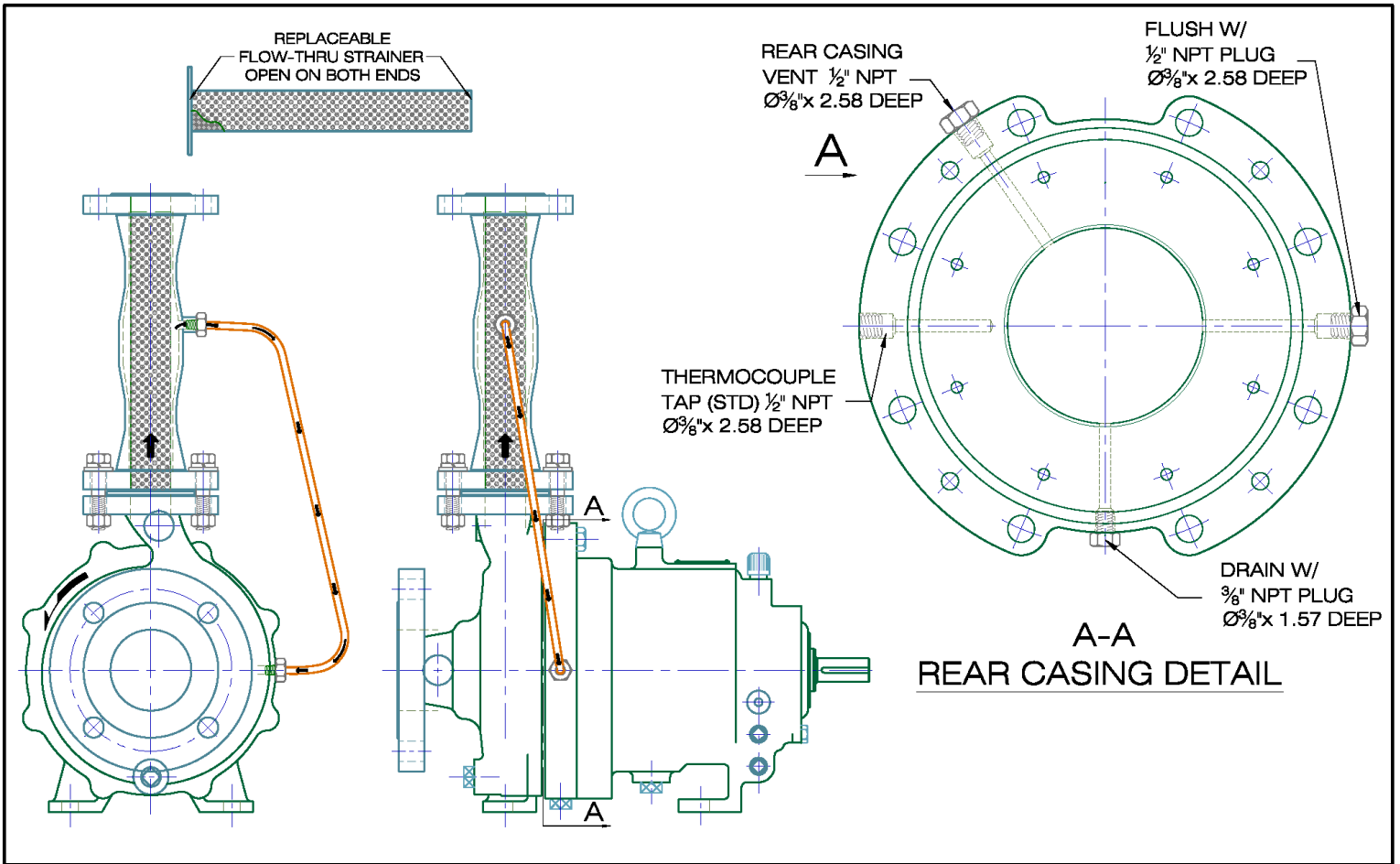

LONG-COUPLED, ANSI DIMENSION, MAXP SERIES, RECIRCULATED OR EXTERNAL FLUSH

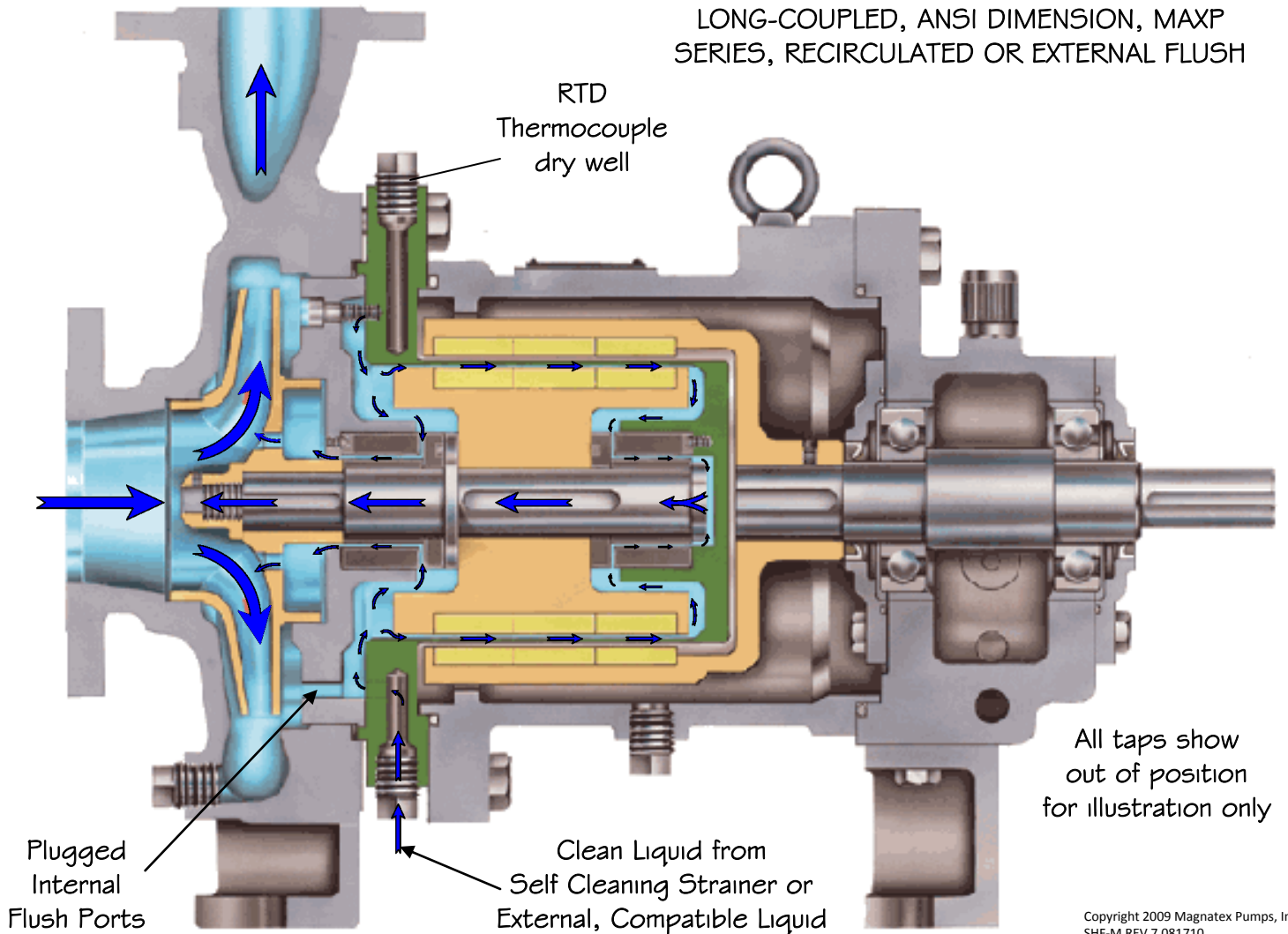

Magnachem™ Baseplates

Eliminate the need to replace corroded metal baseplates under your process pumps!

Magnatex® Pumps, Inc. offers a new line of cast, Quartz Ceramic Baseplates for long service life and perfect alignment every time. Every long coupled Magnatex® Pump is laser aligned before it leaves the factory to ensure ease of realignment at the job site.



Compared to fabricated steel baseplates, Magnachem Baseplates:

- Are flat to within .002"/ft which ensures perfect pump and motor alignment, every time
- Feature completely rigid quartz ceramic cast construction which eliminates flexing, twisting and misalignment issues common to fabricated steel baseplates
- Provides a broad range of chemical resistance which eliminates corrosion issues common to steel baseplates
- Lower lifetime cost of ownership than steel baseplates

Magnachem Baseplates include:

- Center grout hole for easy installation
- Catch basin with a threaded drain connection located under the pump stuffing box/seal chamber area, to safely transfer any leakage
- Tapped thru holes in each corner of the baseplate to facilitate baseplate leveling
- Heavy duty, 316SS, tapped inserts for mounting pump, motor and coupling guard

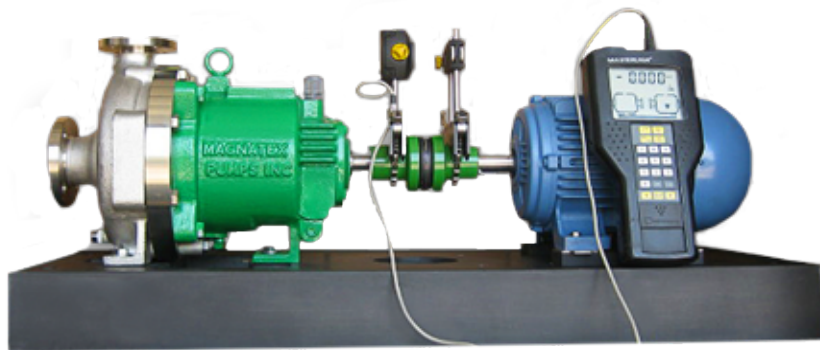

Anatomy of the Ultimate Magnetic Drive Pump

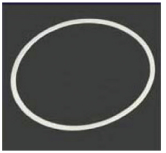

Single confined gasket is the only "seal" in the pump

Standard RTD well tap and vibration monitoring mounting point for predictive maintenance programs



Anti-contact ribs prevent outer magnet from rubbing on the rear casing. In the event of external ball bearing failure, to prevent breaching the primary containment barrier

Large internal radial clearance: 0.060" minimum, allows passage of a modest amount of solids in the rear casing area of the pump



Fully enclosed impeller with balance holes provides high efficiency and low thrust (no shims or adjustments required)



Inducers available for low NPSH applications



Standard SIC bearing system or optional SIC-X material for potential "upset" or dry running

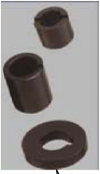

Inner magnet is "straddle" mounted between bearings (no overturning load) allowing operation across the complete curve without shaft deflection



Casing drain allows complete draining of the pump and rear casing



External flush to rear casing of the pump from a self-cleaning strainer or compatible external source allows handling liquids with entrained solids

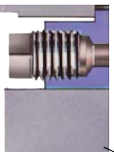

Standard instrumentation port for detection of primary containment leakage

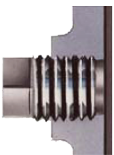

Neodymium or optional samarium cobalt magnets for high-temperature operation provide synchronous drive (no slip)



Rugged rear containment shell with Alloy C material between the inner and outer magnets provides high efficiency, greater component strength, enhanced corrosion resistance and positive hermetic sealing

Several optional secondary containment designs are available, if necessary

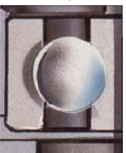

Oil-lubricated bearings (easily adaptable to oil mist) or optional greased-for-life bearings provide extra long life because of the minimal load of the outer magnet — no axial loading

Cooling fins and ports on bearing frame allow non-cooled operation to 350°F. For higher temperatures optional cooling systems are available



MAXP Series Composite Curves

CAPACITY @ 3550 RPM / 60hz (Green Scale)

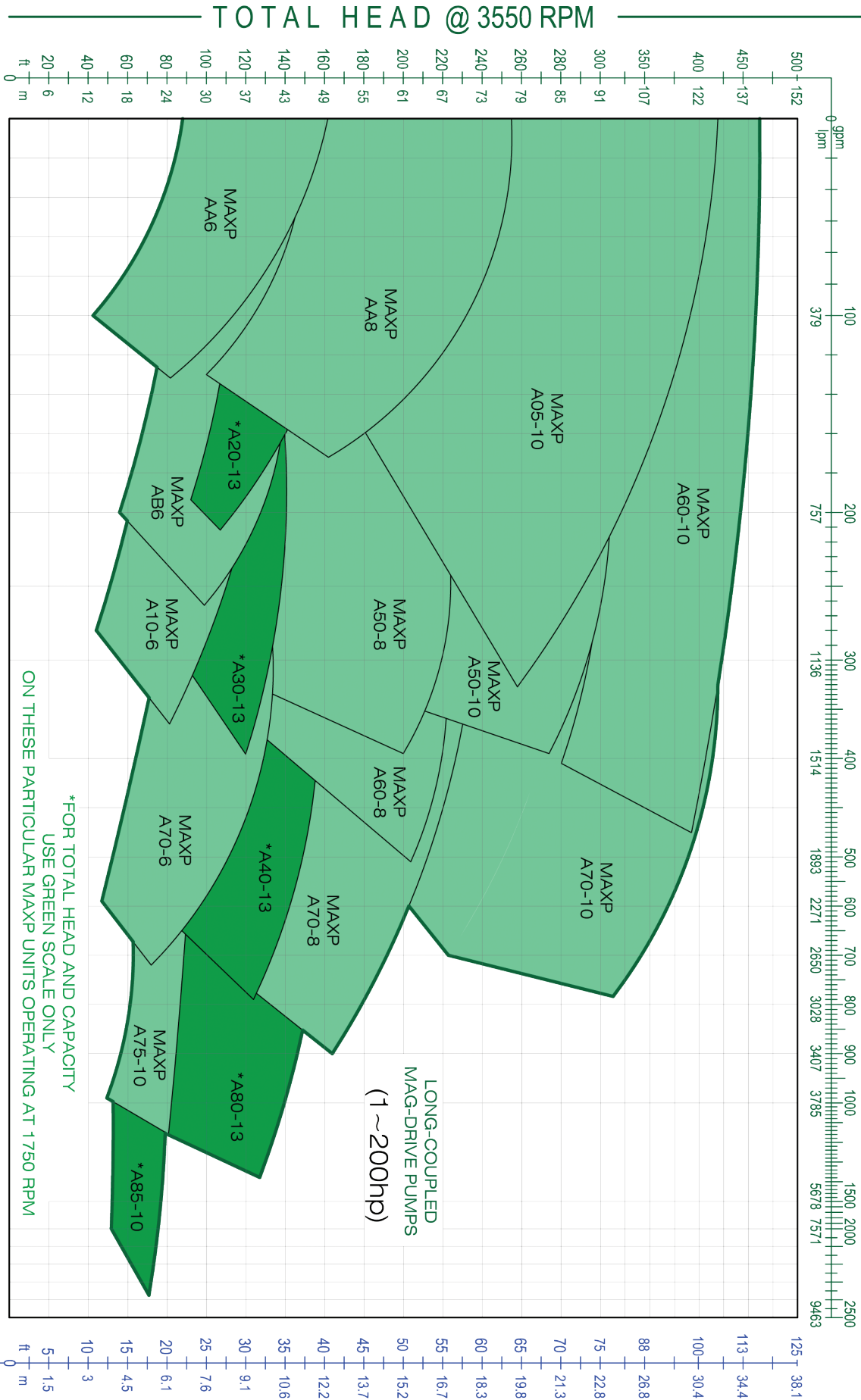

TOTAL HEAD @ 3550 RPM

TOTAL HEAD @ 1750 RPM

CAPACITY @ 1750RPM / 60hz (Blue Scale)

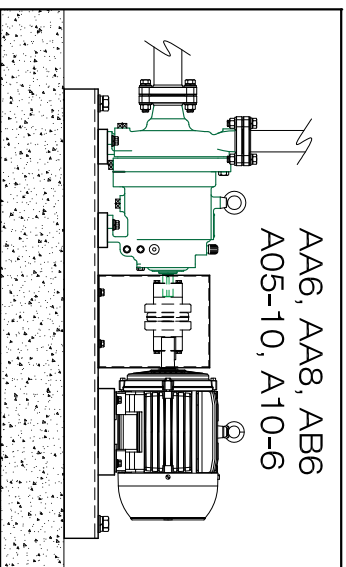

INSTALLED ANSI PUMP

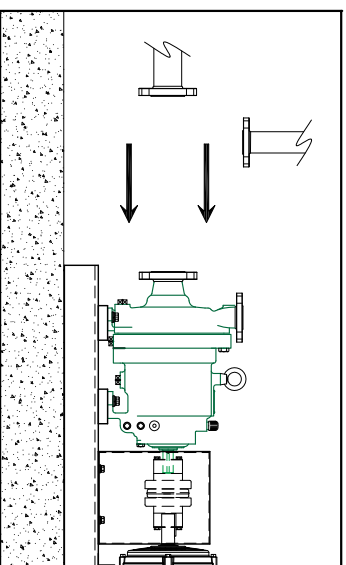

REMOVE ANSI PUMP AND BASEPLATE

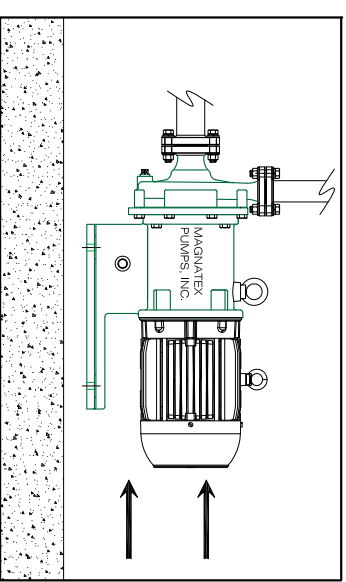

MAGNATEX MP/MPL PUMP w/o ADAPTER BLOCK

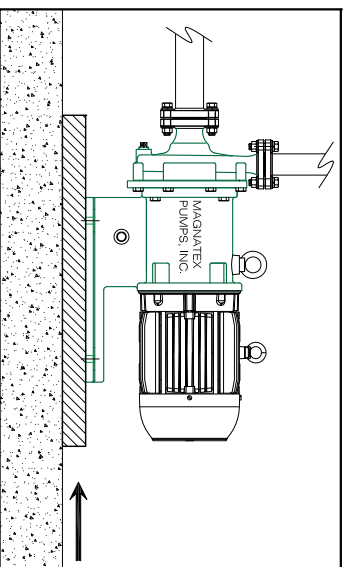

INSERT ADAPTER BLOCK AND ANCHOR APPROPRIATELY

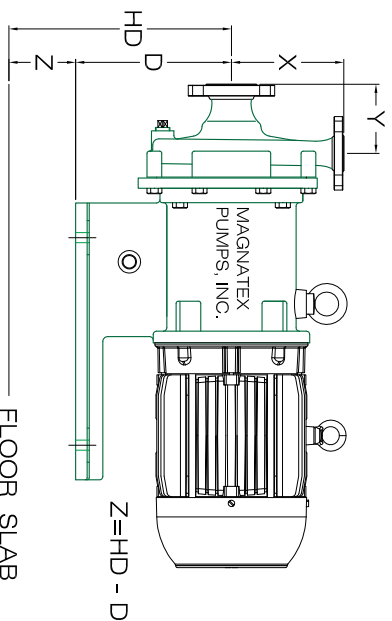

MODEL	ANSI PUMP	MP / MPL			ANSI			Z +/- 0.13 [3mm]		
MP/MPL SERIES MP423 1.5 x 1 x 7	AA6 1.5 x 1 x 6	X	Y	D	X	Y	BASE	HD		
		6.50 [165]	4.00 [101]	9.00 [228]	6.50 [165]	4.00 [101]	139 [9.00] [228]	148 [10.50] [266]	153 [12.88] [327]	0.00 [0]
MPL40 1.5 x 1 x 6	AA8 1.5 x 1 x 8	6.50 [165]	4.00 [101]	9.00 [228]	6.50 [165]	4.00 [101]	139 [9.00] [228]	148 [10.50] [266]	153 [12.88] [327]	0.00 [0]
MPL42 & MPL42LF 1.5 x 1 x 8	AB6 3.15 x 6	6.50 [165]	4.00 [101]	9.00 [228]	6.50 [165]	4.00 [101]	139 [9.00] [228]	148 [10.50] [266]	153 [12.88] [327]	0.00 [0]
MP842 MPL 84 3 x 1.5 x 6	A05-10 2 x 1 x 10	6.50 [165]	4.00 [101]	9.00 [228]	6.50 [165]	4.00 [101]	139 [9.00] [228]	148 [10.50] [266]	153 [12.88] [327]	0.00 [0]
* MPL52LF 2 x 1 x 10	A10-6 3 x 2 x 6	6.50 [165]	4.00 [101]	9.00 [228]	6.50 [165]	4.00 [101]	148 [10.50] [266]	153 [12.88] [327]	153 [12.88] [327]	1.50 [38]
* MPL85 3 x 2 x 6		8.25 [209]	4.00 [101]	9.00 [228]	8.25 [209]	4.00 [101]	139 [9.00] [228]	148 [10.50] [266]	153 [12.88] [327]	0.00 [0]

* BASEPLATE MAY BE LEFT IN PLACE AND ADAPTER BLOCK THICKNESS ADJUSTED AS NEEDED. (REVIEW OLD BASE MOTOR PAD HEIGHT)

ALL DIMENSIONS IN INCHES [mm]

CAPACITY @ 3550 RPM / 60hz (Green Scale)

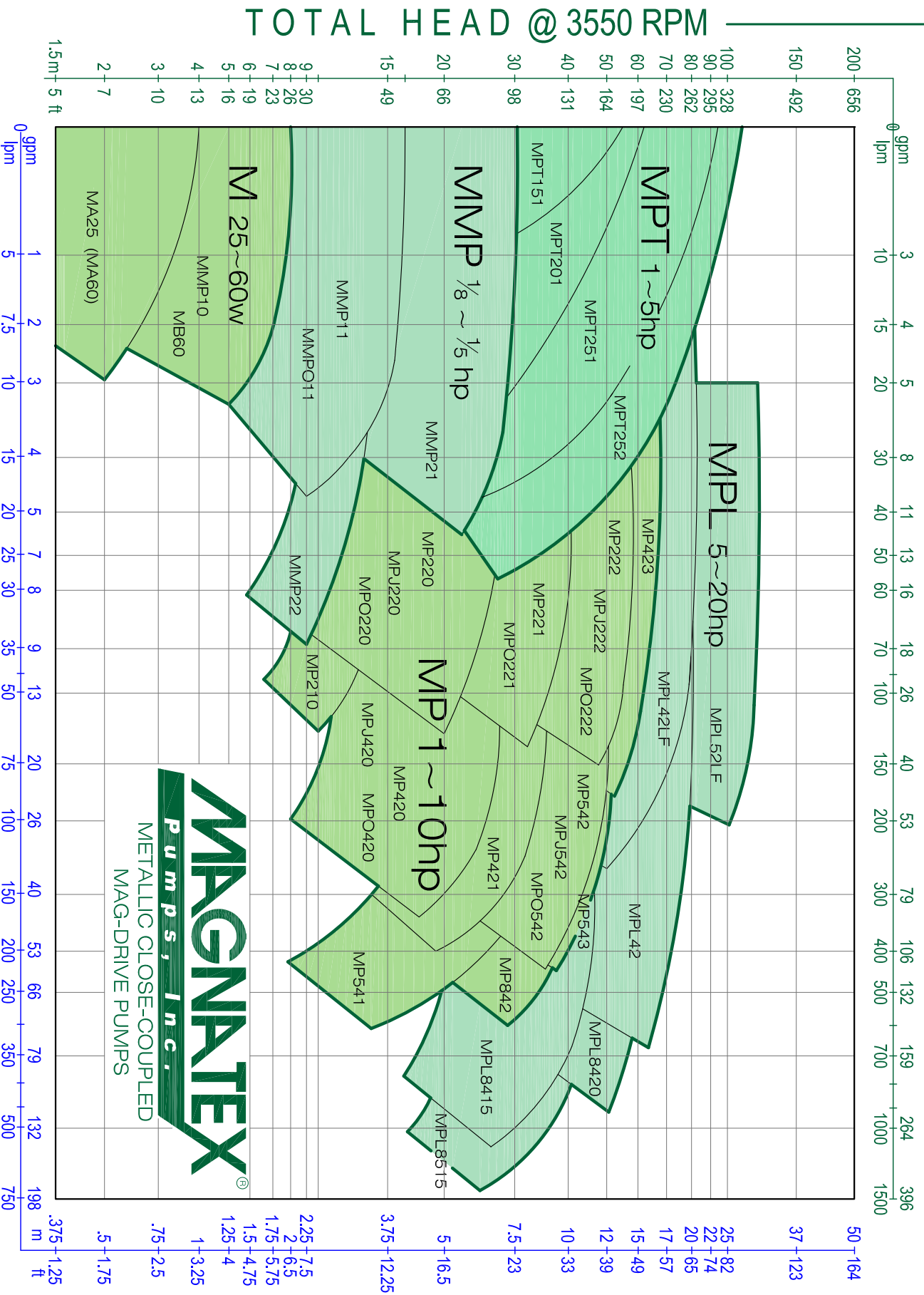

CAPACITY @ 1750RPM / 60hz (Blue Scale)

You wouldn't drive your car with the gas pedal floored, using the brake to control your speed, however many pump users use the exact same approach to control their pumps. The solution? Variable Frequency Control of AC induction motors provides an economical and operationally effective solution for speed control and reduced power consumption. VFDs can be made responsive to signals from many sources such as flow sensors, pressure sensors, programmable controllers, etc. AC motor controls will enhance your process efficiency and profitability.



D700 Series

Low Cost Sub-Micro VFD

- Digital setting dial with integrated display making configuration fast and easy
- Control remotely or with built-in digital control
- Low cost and Mitsubishi Electric quality ensure solid solutions
- Magnetic Flux Vector Control with auto-tuning
- Safety stop function



E700 Series

'Big Drive' Vector Control Capability in a micro drive - delivering outstanding performance for a wide range of demanding loads

- Advanced Magnetic Flux Vector Control gives 120:1 speed range
- All capacities have built-in brake chopper
- USB communications for fast commissioning
- Standard RS 485 serial communications supporting Modbus RTU
- Supports Remote I/O function via network
- 200 % Overload for 3 seconds



E560 Series

The cost-effective variable speed control solution for general purpose applications

- Magnetic Flux Vector Control
- Auto-tuning
- Selectable cooling fan operation mode
- Adjustable carrier frequency (0.7kHz to 14.5kHz)
- Compatible with FR-PU04 user interface
- UL & cUL listed / CE marked



F700 Series

Built to optimize 3-phase motor control, saving energy for virtually all general purpose applications.

- UL Type 1, plenum rated, enclosure designs (NEMA 1)
- Built-in EMC filter
- FR-DU07 programming dial and FR-Configurator programming software
- Bi-directional coasting motor restart
- RS-485 communications as standard (Modbus RTU or Mitsubishi Electric)
- Upgrade of energy optimization control
- Control terminals can be used over a network as remote I/O
- FR-PU07BB-L keypad - programs the drive without powering-up
- UL listed for single phase input



A700 Series

Advanced performance makes it possible to support a wide range of variable speed applications from conveyance and chemical machines to line control applications such as winding and printing machines. Improved flexibility allows users to tailor their VFD to meet their application requirements.

- Real Sensorless Vector (RSV) Control achieves 200% torque at speeds as low as 0.3Hz
- Built-in PLC function allows users to create customized applications
- Positioning Control as standard allows simple moves from position to position
- Sensorless Torque Control can be utilized for wind/unwind applications
- Two RS-485 serial ports and one USB port make connectivity flexible
- FR-PU07BB-L keypad - program the drive without main power
- UL listed for single phase input

Model Series		D700				E560	E700				F700		A700		
Voltage Range (VAC)		115 1Ø	240 1Ø	240	480	600	115 1Ø	240 1Ø	240	480	240	480	240	480	600
HP Range	Constant Torque	1/8-1	1/8-3	1/8-10	1/2-10	1-10	1/8-1	1/8-3	1/8-20	1/2-20	1-200	1-1000	1/2-125	1/2-800	1-650
	Variable Torque												1-200	1-1000	2-850
Control Algorithm	Open-Loop Flux Vector Speed	Yes				Yes	Yes				No		Yes		
	Open-Loop Torque	No				No	No				No		Yes		
	Closed-Loop Speed	No				No	No				No		Yes		
	Closed-Loop Torque	No				No	No				No		Yes		
	Closed-Loop Position	No				No	No				No		Yes		
Inputs	Digital Inputs	5 (2 additional for Safety)				7	7 (expandable)				12 (expandable)		12 (expandable)		
	0-5 / 10VDC	Yes				Yes	Yes				No		No		
	0-±5 / ±10VDC	No				No	No				Yes		Yes		
	4-20mA	No				Yes	No				No		No		
	4-20mA or 0-5/10VDC	Yes				No	Yes				Yes (2 ports)		Yes (2 ports)		
	Pulse (Speed)	No				No	No				No		Yes		
Outputs	Digital Outputs	1				2	2 (expandable)				5 (expandable)		5 (expandable)		
	Relay Outputs	1				1	1 (expandable)				2 (expandable)		2 (expandable)		
	0-10VDC	Yes				Yes	Yes				Yes		Yes (expandable)		
	0-20mA	No				No	No				Yes		(optional)		
	Pulse	No				No	No				No		Yes		
Communications	Modbus RTU	Standard				No	Standard				Standard		Standard		
	CC-Link	No				Option	Option				Option		Option		
	DeviceNet	No				Option	Option				Option		Option		
	Profibus-DP	No				Option	Option				Option		Option		
	LonWorks	No				Option	Option				Option		Option		
	SSCNETIII	No				No	No				No		Option		
	ControlNET	No				No	No				No		Option		
	Metasys N2	Option				Option	Option				Option		Option		
	Siemens FLN	Option				Option	Option				Option		Option		
	BACnet/MSTP	Option				Option	Option				Option		Option		
	EtherNet/IP	Option				Option	Option				Option		Option (2 types)		
	Modbus TCP/IP	Option				Option	Option				Option		Option		
	BACnet/IP	No				No	Option				Option		Option		
Brake Transistor	Yes (1/2HP and above)				Yes	Yes (1/2HP and above)				No		Up to 30HP			
Brake Resistor	Option				Option	Option				No		Up to 10HP	Up to 5HP		
EMC Filter	Option				No	Option				Standard		Standard	No		
DC Reactor	Option				No	Option				Option (standard 100HP and above)					
Safety Stop Function	Standard				No	Option				No		No			
Communications Ports	1 (RS-485)				1 (RS485)	2 (RS-485 & USB)				2 (RS-485)		3 (2x RS-485 & USB)			
Plug-in Option Ports	0				1	1				1		3			
Operator Interface	Standard				Option	Standard				Standard		Standard			
Alpha/Numeric Keypad Option	FR-PU07				FR-PU04	FR-PU07				FR-PU07 FR-PU07-01		FR-PU07			
Alarm History	Last 8				Last 8	Last 8				Last 8		Last 8			

Variable Frequency Drives Family

Standard Features:

- RS-485 serial communications (Mitsubishi VFD protocol)
- PID control
- Adjustable carrier frequency (Low Noise) up to 14.5kHz
- Soft PWM
- Packaged solutions available
- Setup Software available
- User selectable Sink (default) / Source I/O



3575 West 12th Street Houston, TX 77008
 tel: 713.972.8666 toll free: 866.MAGPUMP fax: 713.972.8665
www.magnatexpumps.com



V-Series Control System

The UPC and V-Series Load Controls

protect equipment driven by Variable Speed Motor Drives



V-Series Control



UPC/UPC-FR Power Cell

V-Series Load Controls and UPC Power Cells are used together to protect equipment in Variable Speed motor drive applications. The UPC monitors motor power and sends a 0-10V signal to the V-Series Load Control. Each Load Control has adjustable set points and relay outputs. The set point configuration differs depending on the application and is called out by a specific model number.

The UPC measures True Power (Watts) on the output side of AC or DC motor drives and is field scaleable from small motors to 150 HP. Response time is field adjustable from 500 ms to 12 Sec. The UPC-FR has a fast Response time field adjustable from 50 ms to 1.2 Sec.

The V-Series Load Controls read the measured load on a digital display in either HP, KW or % Load. The meter also reads the set point and delay settings during setup. A HIGH trip set point will trip an output form C relay on an increase in load and a LOW trip set point will trip an output form C relay on a loss of load. Reset can be done manually, remotely with a switch or automatically using jumpers on the resets. A 4-20ma analog output is also provided.

- PFR-1550V - Has one adjustable set point that can be programed for either HIGH trip or LOW trip.
- PFR-1750V - Has two adjustable set points that are configured for HIGH trip.
- ROC-50V - Has two adjustable set points. One is configured for HIGH trip (Max. Limit) and the other is a RATE OF CHANGE set point that reacts to fast acting loads like jam conditions on conveyors, indexing equipment etc. Use with UPC-FR for Fast Response.
- PMP-25V - Has two adjustable set points configured for HIGH trip and LOW trip.

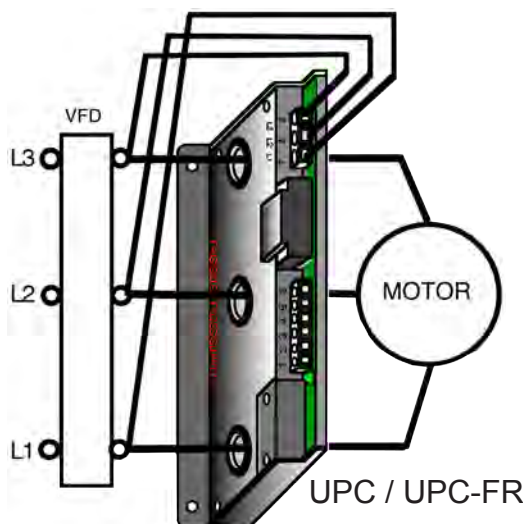

1. 4-20MA Analog Output
2. Analog Ground
3. 10V Analog Output
4. Chassis Ground
5. 120VAC
6. 120VAC
7. L1
8. L2
9. L3

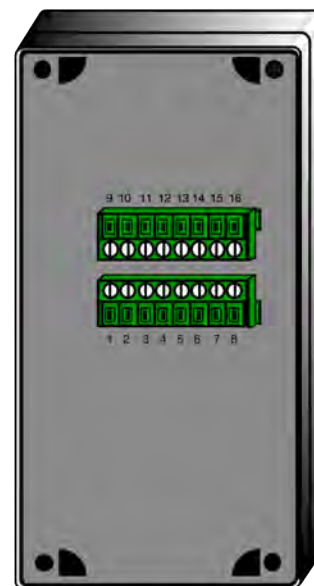

V-Series Back View

- | | |
|----------------------------|------------------|
| 1. Chassis / Static Ground | 10. Relay 1 N.C. |
| 2. 4-20MA Positive | 11. Relay 1 Com. |
| 3. 4-20MA Negative | 12. Relay 2 N.O. |
| 4. Reset | 13. Relay 2 N.C. |
| 5. Reset | 14. Relay 2 Com. |
| 6. Reset Common | 15. 120 VAC |
| 7. 10V Input Positive | 16. 120 VAC |
| 8. 10V Input Negative | |
| 9. Relay 1 N.O. | |

Notes:
 *The 0-10V signal (terminals 2 and 3) from the UPC power cell wires to the V-Series Load Control (terminals 8 and 7). A shielded signal wire should be used and the shield connected to GROUND at one end.
 *Relay outputs on the V-Series Load Control are shown with POWER ON and NOT TRIPPED. The trip condition is the shelf state.

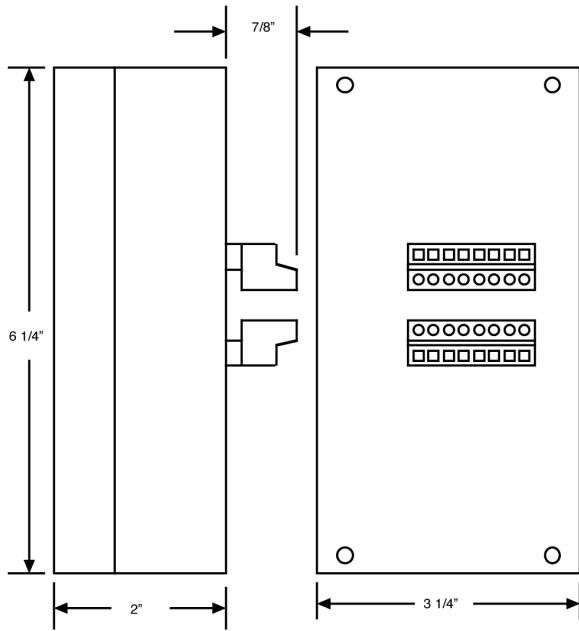

V-Series Control

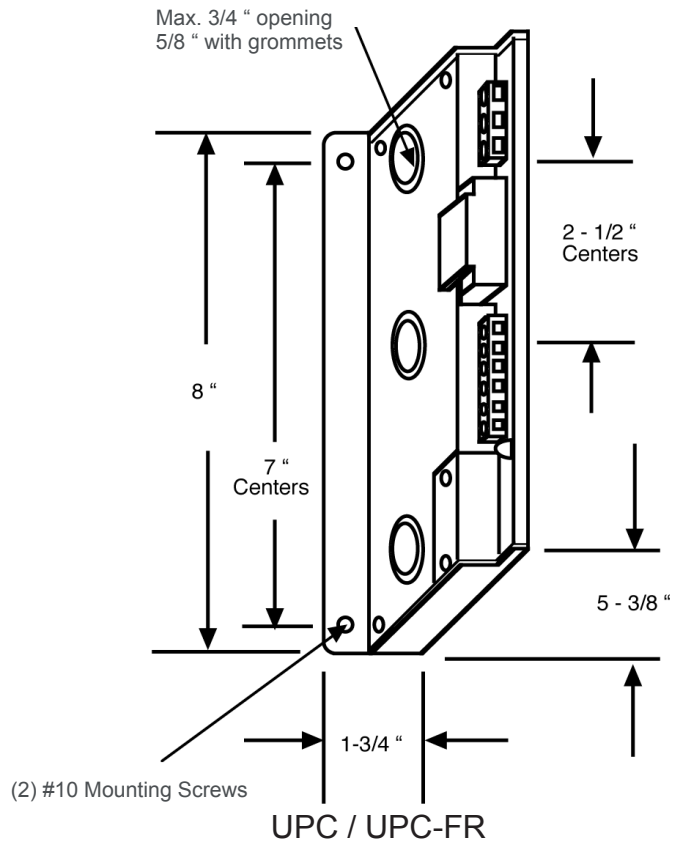

BEZEL Installation
Mounting Hardware Provided

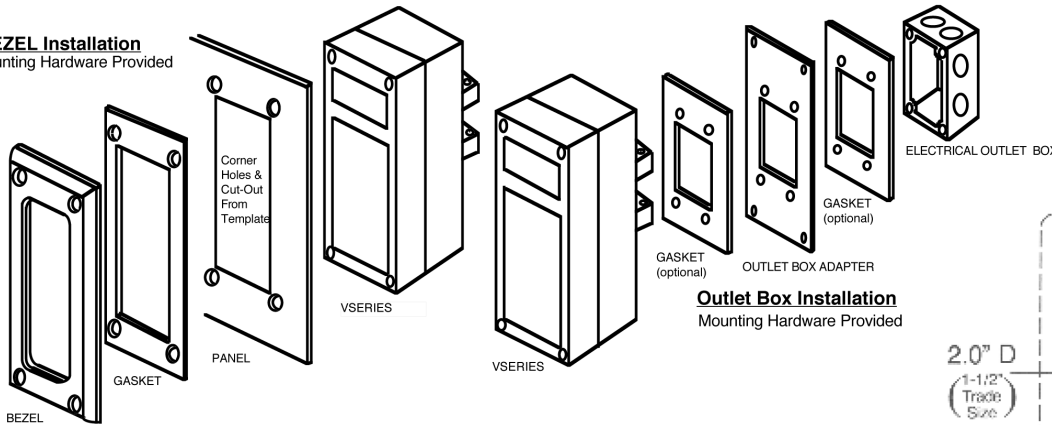

Outlet Box Installation
Mounting Hardware Provided

Mounting Template (not to scale)

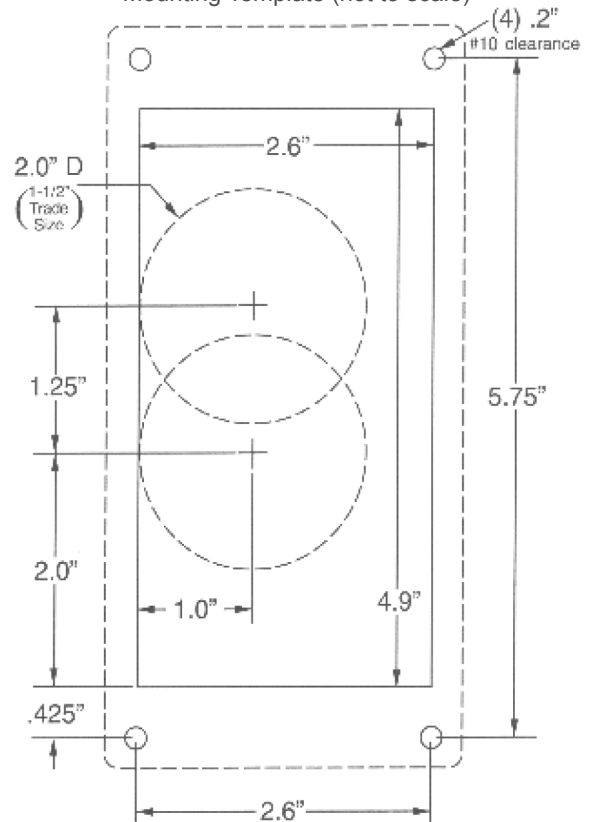

The Mounting Template ships with the V-series control and is used to mark hole punches for mounting on the outside of a panel door or raceway. To mount behind panel door or raceway use template to make a rectangular cut out and the BEZEL is used. Ask for the BEZEL kit when ordering (no charge). Gaskets are provided for both mounting options to maintain NEMA 4 integrity.

The OUTLET BOX ADAPTER is used for a surface or backplane mount. This adapter will adapt to an OUTLET BOX so the V-Series connectors are spaced off the backplane of the panel. Ask for OUTLET BOX ADAPTER when ordering (no charge). Gaskets are provided.



API-685, 2nd Edition

Sealless Centrifugal Pumps for Petroleum, Heavy Duty Chemical, and Gas Industry Services

Comments and Clarifications

1. **SCOPE** These comments apply to API-685 – 2nd Edition, February 2011. The API authors of this specification for Sealless Centrifugal Pumps for Petroleum, Heavy Duty Chemical, and Gas Industry Services wisely recognized there are numerous applications within the API and related markets for which the service requirements can be satisfied with pumping equipment that does not fully comply with the API-685 standard. Stated differently, there are service requirements within the API market that can be readily satisfied with a sealless mag-drive centrifugal process pump conforming to ANSI B73.1M which comply with the “not to exceed” values listed in the Scope of API-685. An owner of a process plant can benefit from several characteristics of a bonafide sealless mag-drive pump, such as provided by Magnatex Pumps, Inc., when compared with an API-685 compliant pump. Some of those benefits are:
 - a. Greatly reduced lead time for unit supply with many models in 316SS construction available from stock in a matter of 1-4 weeks for routine requirements. When needed, pumps and parts can be supplied in a matter of hours for emergency situations.
 - b. Spare parts availability from manufacturer stock, which reduces owner stock requirements.
 - c. Rugged design provides highly reliable service life.
 - d. Enhanced resistance to upset conditions with available SiC-X patented bearing material.
 - e. Reduced initial cost as excess design requirements are removed from the equipment specifications.

Specific comments by section follow. Sections not addressed are considered to be in compliance.

2. **6.1.31** Bolting and Threads
3. **6.1.31.1** Bolting and threads shall be the JIS equivalent to ISO-261.
4. **6.1.34** Cap screws and studs are used as appropriate to facilitate field maintenance. All pressure retaining and wetted internal fasteners are a minimum of 316SS. External non-wetted process pressure retaining fasteners are 304SS.
5. **6.1.36** Fasteners - Marking of bolts will be in accordance with applicable JIS specifications.
6. **6.2.5** The can portion of the containment shell is constructed of Hast C for superior corrosion resistance, lower hysteresis losses (less heating, lower power consumption), and greater strength to thickness ratio allowing can thickness of 1 mm. An overlap welding technique provides superior weld strength compared to other manufacturing methods.
7. **6.2.7** The casing gasket is the only process side joint seal and is a confined, controlled-compression gasket bounded by metal-to-metal rabbeted fit.
8. **6.3.2.2** Flange surfaces comply with ISO 7005-1 smooth finish requirements and the standard raised face flange configuration provides excellent sealing characteristics within the pump design parameters for most liquids. Serrated spiral or concentric grooves complying with this section are available as an option at additional costs.
9. **6.3.2.4** Flanges are full faced on the back of the flanges except where studs are used at the pump suction connection as allowed by ASME B73.3M
10. **6.3.3.11.2** All tapered pipe threads are NPT in accordance with ASME B1.20.1.



API-685, 2nd Edition

Sealless Centrifugal Pumps for Petroleum, Heavy Duty Chemical, and Gas Industry Services

Comments and Clarifications

11. 6.4 External Nozzle Forces and Moments - External Forces and Moments are in accordance with the attached document ED-3603, which contains maximum values in keeping with the standard maximum allowable working pressure (MAWP) of the MAXP series. Please note these values are quite robust in that all values comply with higher allowable values than specified in all sizes except the 1" connection Fx and Fz axes, and Mx and Mz bending moments. The best system design characteristics include adequate piping support to prevent pipe loading moments and forces from being transferred to the pump. This helps extend pump service life and lengthen intervals of MTBPM.
12. 6.6 Wear Rings - Wear rings are not furnished. The tolerances of the product lubricated hydrodynamic bearing system and stiff, compact rotor design eliminate the need for wear rings for operation within the allowed operating range.
13. 6.7 Secondary Containment – Magnatex offers secondary control design (3.67) and secondary control with primary leakage monitoring devices (3.68) to be determined by the mutual agreement with the Purchaser. Failure of primary containment shell is rare, occurring only when a damaged pump is operated until breach of the primary containment occurs. Installation of reliable equipment instrumentation and careful operation will eliminate loss-of-primary-containment events.
14. 6.7.3 Secondary Control corrective action must be taken as soon as possible to isolate the source of primary leakage to assure integrity of the control system.
15. 6.7.5 Secondary pressure containment casing is ductile iron. Carbon Steel or SS secondary pressure containment is available at additional costs. Pressure capabilities are dependent upon inboard bearing seal rating.
16. 6.7.6 Secondary pressure containment casing is ductile iron. Carbon Steel or SS secondary pressure containment is available at additional costs.
17. 6.8.3 Vibration – Manufacturer's standard vibration testing during performance testing of the Magnatex MAXP model range consists of an overall vibration level check established to produce performance at or near 3.0 mm/sec RMS depending on model and operating point. The following components are balance checked; Impeller, Inner Magnet, and Outer Magnet, all to the following levels:
 - a. Balance G16 for 1800 rpm and below
 - b. Balance G6.3 for >1800 rpm and capacity \geq 264 gpm
 - c. Balance G6.3 for >1800 rpm and multistage
 - d. Balance G6.3 for >3600 rpm

These balancing criteria gleaned from years of historical test data, coupled with the hydrodynamic bearing system and stiff shaft design (Magnatex' Straddle Mount Bearing System), produce operating vibration levels at or near table 6 overall vibration levels. If strict compliance with table 6 values is required (6.8.3.2 and 6.8.3.4) additional balancing and testing costs will apply.
18. 6.9.4 Tolerance rings are not used. Pumps are matched to required temperature ranges while still maintaining the slip-fit maintenance features and benefits. Bushing bearing system component is available in SiC-X material with a coefficient of friction that is $\frac{1}{4}$ that of standard SiC material.



API-685, 2nd Edition

Sealless Centrifugal Pumps for Petroleum, Heavy Duty Chemical, and Gas Industry Services

Comments and Clarifications

19. 6.9.2 Front and Rear Thrust Ring SiC bearing system components are equal in size and interchangeable parts allowing stable operation over the recommended operating range.
20. 6.9.9.2 Threaded connection for permanent mounting of vibration transducer is standard for the MAXP.
21. 6.10.3 All welding and qualification of weld personnel will be in accordance with JIS standards.
22. 7.4 Instrumentation and control systems when required will be matched to the application requirements specified by the purchaser. Additional costs will apply. A power monitor has been quoted as an available option.
23. 7.5 Piping and Appurtenances - Piping and appurtenances for auxiliary systems when required will be matched to the application requirements specified by the purchaser. Additional costs will apply.
24. 7.6 No special tools are required for maintenance of Magnatex pumps. Our pumps are designed with slip-fit construction to facilitate field maintenance for lowest cost of ownership.
25. 8 Inspections and Testing are tailored to the specific job requirements as required. Additional costs may apply.

Our standard weld inspections of Class I (<80% MAWP or <200°C [390°F]) and Class II (>80% MAWP or >200°C [390°F]) pressure casings, cast or wrought, consist of visual inspection and dye penetrant examination performed in accordance with section 8.2.2.1, Table 9 requirements. Magnetic particle and radiography material testing requirements will incur additional charges.

Manufacturer's standard production testing consists of performance test with five test points, overall vibration level, overall sound power level, and hydrostatic pressure testing of pressure retaining components, and an assembly air pressure check of the pump assembly. Duty point NPSHr testing is conducted when NPSHa is within 1.5m (2ft) of NPSHr. Additional costs may apply. Test requirements outside of the manufacturer's standard production scope will incur additional costs based on the specific requirements.

26. 9.1.2 Pressure Containment – The pressure containment shell design and manufacturing method is proprietary. It produces a rigid design that resists deflection and each containment shell is pressure tested twice, once with liquid at 1.5 times MAWP and once with air/N₂ gas at 1.1 times MAWP. The shell is subjected to non-destructive testing of the welds and each assembled pump is performance tested and checked for vibration, noise, and proper operation. We have had no failures of the pressure containment shell from design related or materials issues.
27. 9.1.3.4 Outer Magnets for the smallest size magnet frames (F Series) are threaded in the direction of rotation (tightening) and set screwed in place onto the Outer Shaft, not keyed. All other Outer Magnets are keyed to the shaft for frame sizes S, M, and L, and secured by set screws over the key and at 90° on the outer magnet hub.
28. 9.1.3.5 The outer magnet segments are mechanically spaced and retained with adhesive in machined steps in the outer magnet retaining ring to prevent radial and axial movement independent of the magnet assembly. The inside diameter of the outer magnet front ring extends beyond the inner diameter surface of the magnet segments in close proximity of the rear casing. This prevents contact with the outer diameter on the rear casing containment shell portion of the rear casing during assembly and maintenance operations.



API-685, 2nd Edition

Sealless Centrifugal Pumps for Petroleum, Heavy Duty Chemical, and Gas Industry Services

Comments and Clarifications

Outer magnet sheathing is not required or provided for best functioning of the magnets in the range of pumps supplied by Magnatex Pumps, Inc. The inner magnet is sheathed in the same or a superior material compared to the general materials of construction for wetted parts.

29. 9.1.4.1 Thrust loads are not transmitted to the external rolling element bearings, and as a result the L10 bearing life is in excess of 50,000 hours.
30. 9.1.4.2.4 Water jacket for pump bearing housing is a cored passage in the casting which cools the bearing housing casting thereby cooling the oil that is thrown to the housing walls.
31. 9.1.4.2.6 Bearing isolators of C-PTFE material are provided. These are true non-contact bearing seals. Bronze or SS isolators are available as a priced option for use in areas where C-PTFE is not acceptable.

We welcome your comments and inquiries and will be pleased to respond to any questions you may have about the reliability of our pumps. Contact your Magnatex representative or call us at 713.972.8666 or 866.MAG-PUMP. To view all our products or use our pump selection program, visit our website at www.magnatexpumps.com.



3600 vs. 1800 RPM SPEED CONSIDERATIONS FOR MAGNETICALLY DRIVEN PUMPS

Historically, engineers have preferred to use centrifugal pumps operating at 1800 RPM rather than 3600 RPM, anticipating lower wear rates. In the case of mag-drive pumps, you need to throw all your old thinking out! Higher speed offer many advantages! With Magnatex magnetically driven sealless centrifugal pumps:

- A. **Sealless Construction.** There are no mechanical seals used, so there are no seal to wear out.
- B. **The laws of Physics prevail.** The Affinity Laws dictate that the size of the impeller required varies directly with the speed relative to flow and as the square of the speed for head. In practical terms, since a different pump with different impeller pattern will likely be selected, the impeller diameter needed at 1800 RPM will be double for more the size for a 3600 RPM selection. Not only is the impeller size larger, but also the casing and any other parts associated with the change in impeller diameter.
- C. **No wear considerations.** Impeller and Casing abrasive wear is not an issue as pumping solid laden liquids with sealless pumps is not recommended without an external or recirculated / filtered flush.
- D. **Stable pump bearings.** The internal bearings and thrust rings are made of Silicon Carbide, which has a hardness of Vickers 3100. Even with small amounts of solids, this extremely hard material is very wear resistant, so there should be no concerns.
- E. **No-contact radial bearings.** The internal bearings operate on a hydrodynamic "cushion" of pumped liquid. The higher the speed, the greater the cushion which leads to longer pump life. The effect is similar to a car hydroplaning- if you go too fast, the "cushion" of water under the tires will be sufficient that you lose control; the tires no longer have any contact with the road. The same effect exists with our pumps; the pump sleeve will not have contact with the bearing during operation. The only time the product lubricated, mag-drive pump bearing make contact is during start-up or shut-down.
- F. **Low anti-friction bearing loads.** Since there is not solid connection between the shaft in the bearing housing or motor (for close-coupled pumps) and the inner rotating assembly, thrust loads are not transferred to the bearing frame or motor, and radial loads are extremely low for the ball bearings in the bearing housing or motor (for close-coupled pumps). As an example, for the Magnatex Model AA6-F25, the L₁₀ bearing life is in excess of 300,000 hours, compared to an L₁₀ of only 25,000 hours for a standard mechanical seal ANSI pump.
- G. **Higher speeds mean smaller magnets and lower cost.** Mag-drive pumps have a constant torque magnetic coupling, that is, the magnet horsepower rating changes directly with the speed. To illustrate, a magnet rating for 30hp at 3600 RPM would only be rated for 15hp at 1800 RPM; the 3600 RPM magnet would be much smaller than an 1800 RPM magnet for the same horsepower.

As you can see, from all of these factors, it is much more cost effective to operate at 3600 RPM. In most applications there is no mechanical benefit from operating at lower speeds.

MAGNATEX PUMPS, INC. 3575 WEST 12th STREET HOUSTON, TX 77008 TEL: 713-972-8666 FAX: 713-972-8665 inquiries@magnatexpumps.com		<h1 style="margin: 0;">INQUIRY DATA SHEET</h1>		Date	
				Quote Number	
Customer Name					
Company					
Street					
City		State		Zip Code	
Phone					
Fax					
E-Mail		Representative			

APPLICATION DETAILS

Service Name					
Replace Make		Replace Model			
Budget/Firm		Number of Units			
Tag Number		Materials of Construction			
Liquid		Spec. Heat		Thermal Cond.	
Solids Content		Size		% Weight	
Temperature °F		Specific Gravity		Type	
Vapor Pressure		Flow		Viscosity (cP cSt SSU)	
Suction Pressure		Discharge Pressure		TDH/Diff. Pressure	
NPSHA		Suction Conditions			
Motor Encl.		Cl.		Div.	
VFD Requirements		Grp.		V/Ph/Hz	
				Temp Code	

Sealing Required		Single <input type="checkbox"/> Double <input type="checkbox"/> Dynamic <input type="checkbox"/> Mag-Drive <input type="checkbox"/> Packing <input type="checkbox"/>							
Seal Materials									
Seal Flushing Info									
Materials Required		Casing	Impeller	Shaft	Bearings	Rotor/Idler	Idler Pin	Gskt/O-Rings	Bypass Valve Setting
Other Notes		<p style="color: red; margin: 0;">Any special requirements? We use water to test our pumps. If water is incompatible with your process, please let us know and we will use an alternative pressure test procedure.</p>							

COPYRIGHT MAGNATEX PUMPS, INC. 2021